

1  
2  
3  
4  
5  
6  
7  
8

ALL DIMENSIONS IN MILLIMETRES  
REMOVE ALL SHARP EDGES

THIRD ANGLE PROJECTION  
DO NOT SCALE DRAWING

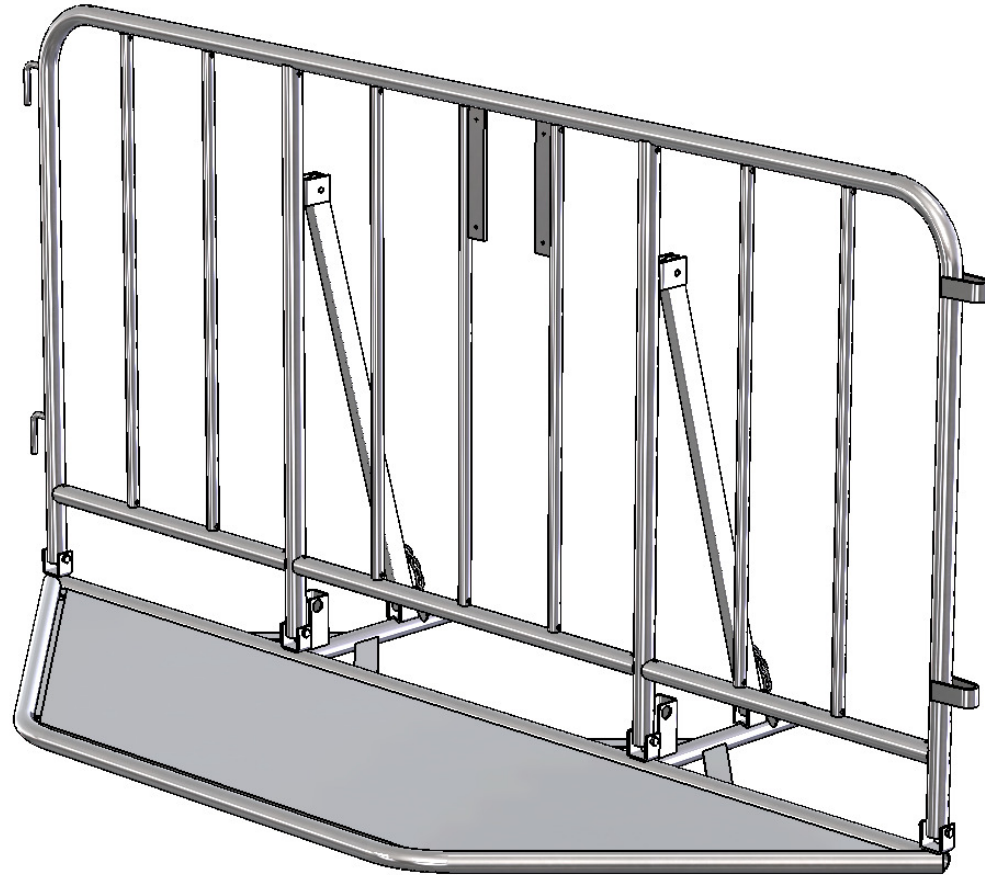

0	29/3/12	ISSUED FOR MANUFACTURE	GC		
P2	5/12/11	ISSUED FOR APPROVAL	GC		
REV	DATE	DESCRIPTION	DRN	CHKD	APPR

TITLE: <b>POLICE BARRIER COLLAPSABLE</b>				MATERIAL: <b>CARBON STEEL</b>	
DRAWN	NAME	SIGNATURE	DATE		
CHK'D	G. CRICK		18/11/11		
FINISH:	<b>HOT DIPPED GALVANISED</b>				
WEIGHT: 48.5 Kg				SCALE: 1:7.5	

**ZNDDE**

Dwg/Stock No.	Revision
<b>ZND501</b>	<b>0</b>

**CODE No. 1066**

UNLESS STATED OTHERWISE		
GENERAL TOLERANCES:		
FABRICATION	UP TO 1000mm	+/- 2mm
	1001mm & ABOVE	+/- 3mm
ANGULAR	+/- 0.5 DEGREE	
WEIGHT	+/- 10% (DUE TO MATERIAL PROPERTIES & TOLERANCES)	

THE COMPANY RETAIN THE RIGHT TO PERIODICALLY ALTER INFORMATION WITHIN THIS DRAWING SHEET AND WILL ATTEMPT TO NOTIFY ALL PARTIES CONCERNED OF ANY CHANGES AND THE INFORMATION ON THIS SHEET SHOULD NOT BE REPRODUCED WITHOUT THEIR WRITTEN CONSENT.

1 ALL DIMENSIONS IN MILLIMETRES  
REMOVE ALL SHARP EDGES

8 THIRD ANGLE PROJECTION  
DO NOT SCALE DRAWING

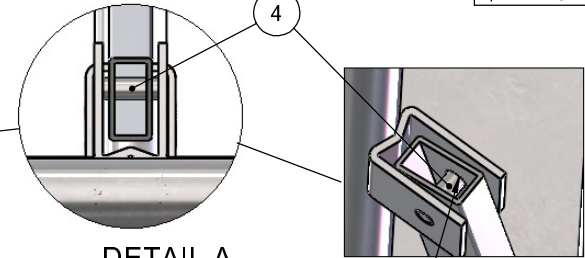
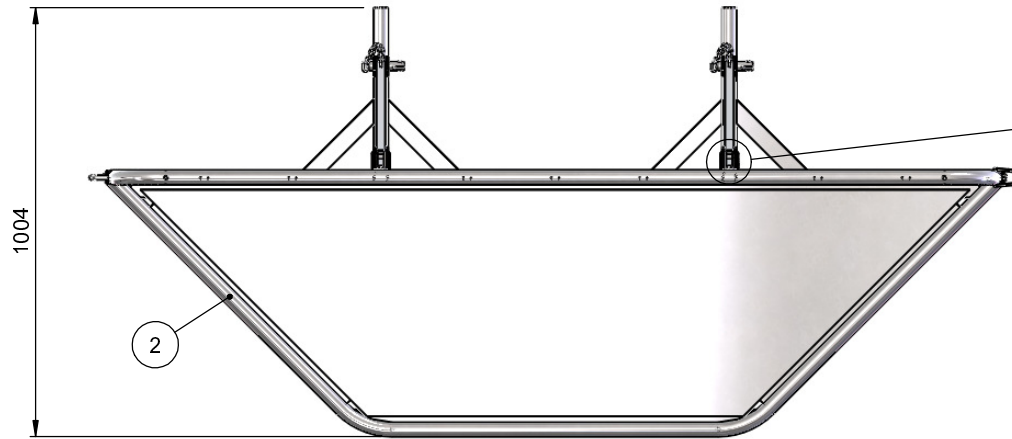

DETAIL A  
SCALE 1 : 2.5  
TYPICAL 2 PLACES

TACK WELD

TACK WELD PIN TO THE  
INSIDE OF THE LEG TUBE  
ON FINAL ASSEMBLY

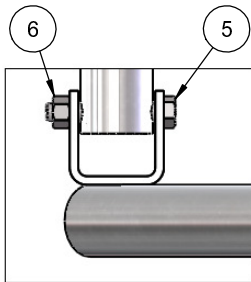
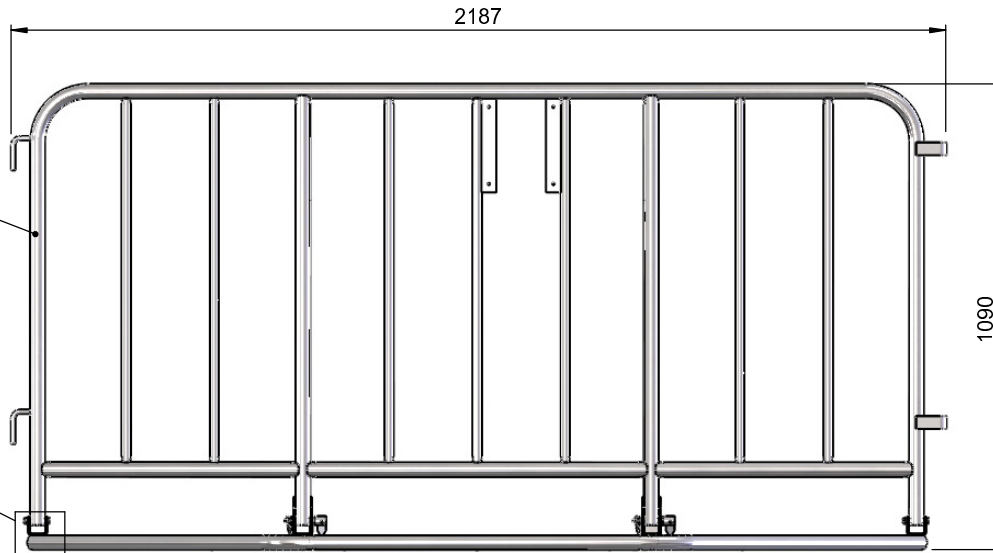

DETAIL B  
SCALE 1 : 2.5  
TYPICAL 4 PLACES

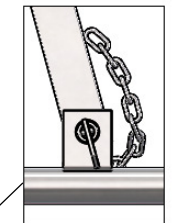
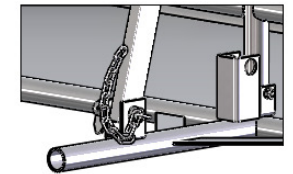

DETAIL C  
SCALE 1 : 5

ALL PARTS TO BE HOT DIPPED GALVANISED  
SEPARATELY BEFORE ASSEMBLY

ITEM No.	PART No.	DESCRIPTION	QTY
1	ZND501-1	BARRIER BASE	1
2	ZND501-2	BARRIER	1
3	ZND501-3	LEG	2
4	ZND501-4	PIN	2
5		M8 x 55 Lg HEX HEAD SET SCREW GALV	4
6		M8 LOCKNUT GALV	4

REV	DATE	DESCRIPTION	DRN	CHKD	APPR
0	29/3/12	ISSUED FOR MANUFACTURE	GC		
P2	5/12/11	ISSUED FOR APPROVAL	GC		

TITLE: <b>POLICE BARRIER COLLAPSABLE</b>				MATERIAL: <b>CARBON STEEL</b>	
DRAWN	NAME	SIGNATURE	DATE		
CHK'D	G. CRICK		18/11/11		
FINISH: <b>HOT DIPPED GALVANISED</b>					

**ZNDDE**

**CODE No. 1066**

THE COMPANY RETAIN THE RIGHT TO PERIODICALLY ALTER INFORMATION WITHIN THIS DRAWING SHEET AND WILL ATTEMPT TO NOTIFY ALL PARTIES CONCERNED OF ANY CHANGES AND THE INFORMATION ON THIS SHEET SHOULD NOT BE REPRODUCED WITHOUT THEIR WRITTEN CONSENT.

Dwg/Stock No. <b>ZND501 - GA2</b>	Revision <b>0</b>
--------------------------------------	----------------------

WEIGHT: 48.5 Kg

SCALE: 1:12.5

SHEET 3 OF 36

A3

1  
2  
3  
4  
5  
6  
7  
8

ALL DIMENSIONS IN MILLIMETRES  
REMOVE ALL SHARP EDGES

THIRD ANGLE PROJECTION  
DO NOT SCALE DRAWING

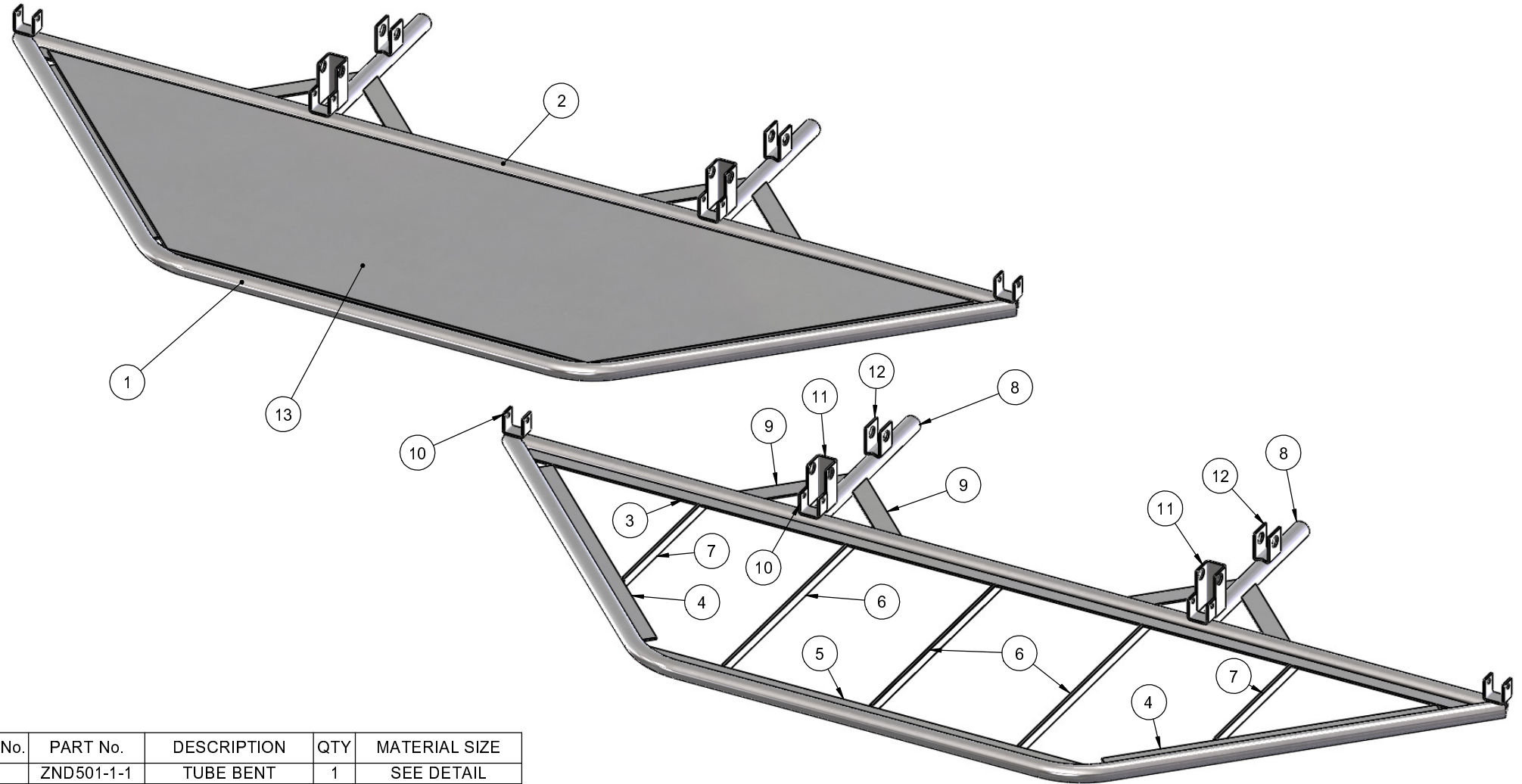

ITEM No.	PART No.	DESCRIPTION	QTY	MATERIAL SIZE
1	ZND501-1-1	TUBE BENT	1	SEE DETAIL
2	ZND501-1-2	TUBE STRAIGHT	1	SEE DETAIL
3	ZND501-1-3	FLOOR SUPPORT 1	1	SEE DETAIL
4	ZND501-1-4	FLOOR SUPPORT 2	2	30 x 5 FLAT x 650 Lg
5	ZND501-1-5	FLOOR SUPPORT 3	1	SEE DETAIL
6	ZND501-1-6	FLOOR SUPPORT 4	2	SEE DETAIL
7	ZND501-1-7	FLOOR SUPPORT 5	2	SEE DETAIL
8	ZND501-1-8	LEG TUBE	2	SEE DETAIL
9	ZND501-1-9	BRACE	4	SEE DETAIL
10	ZND501-1-10	PIVOT BRACKET	4	SEE DETAIL
11	ZND501-1-11	LOCKING BRACKET	2	SEE DETAIL
12	ZND501-1-12	LEG BRACKET	2	SEE DETAIL
13	ZND501-1-13	MESH FLOOR	1	SEE DETAIL

REV	DATE	DESCRIPTION	DRN	CHKD	APPR
0	29/3/12	ISSUED FOR MANUFACTURE	GC		
P2	5/12/11	ISSUED FOR APPROVAL	GC		

TITLE: <b>BARRIER BASE</b>			
UNLESS STATED OTHERWISE	NAME	SIGNATURE	DATE
GENERAL TOLERANCES:	DRAWN	G. CRICK	18/11/11
FABRICATION	UP TO 1000mm	+/- 2mm	CHK'D
	1001mm & ABOVE	+/- 3mm	
ANGULAR	+/- 0.5 DEGREE		
WEIGHT	+/- 10% (DUE TO MATERIAL PROPERTIES & TOLERANCES)		
FINISH:		HOT DIPPED GALVANISED	
MATERIAL:		CARBON STEEL	

**ZNDDE**

Dwg/Stock No. **ZND501-1 - FAB SHT 1** Revision **0**

THE COMPANY RETAIN THE RIGHT TO PERIODICALLY ALTER INFORMATION WITHIN THIS DRAWING SHEET AND WILL ATTEMPT TO NOTIFY ALL PARTIES CONCERNED OF ANY CHANGES AND THE INFORMATION ON THIS SHEET SHOULD NOT BE REPRODUCED WITHOUT THEIR WRITTEN CONSENT.

ALL DIMENSIONS IN MILLIMETRES  
REMOVE ALL SHARP EDGES

THIRD ANGLE PROJECTION  
DO NOT SCALE DRAWING

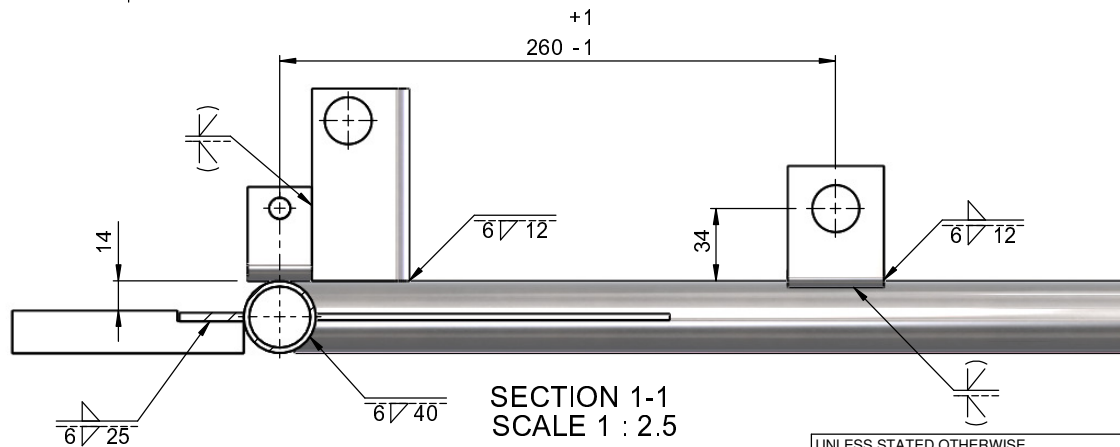
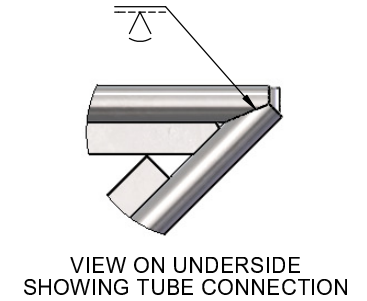
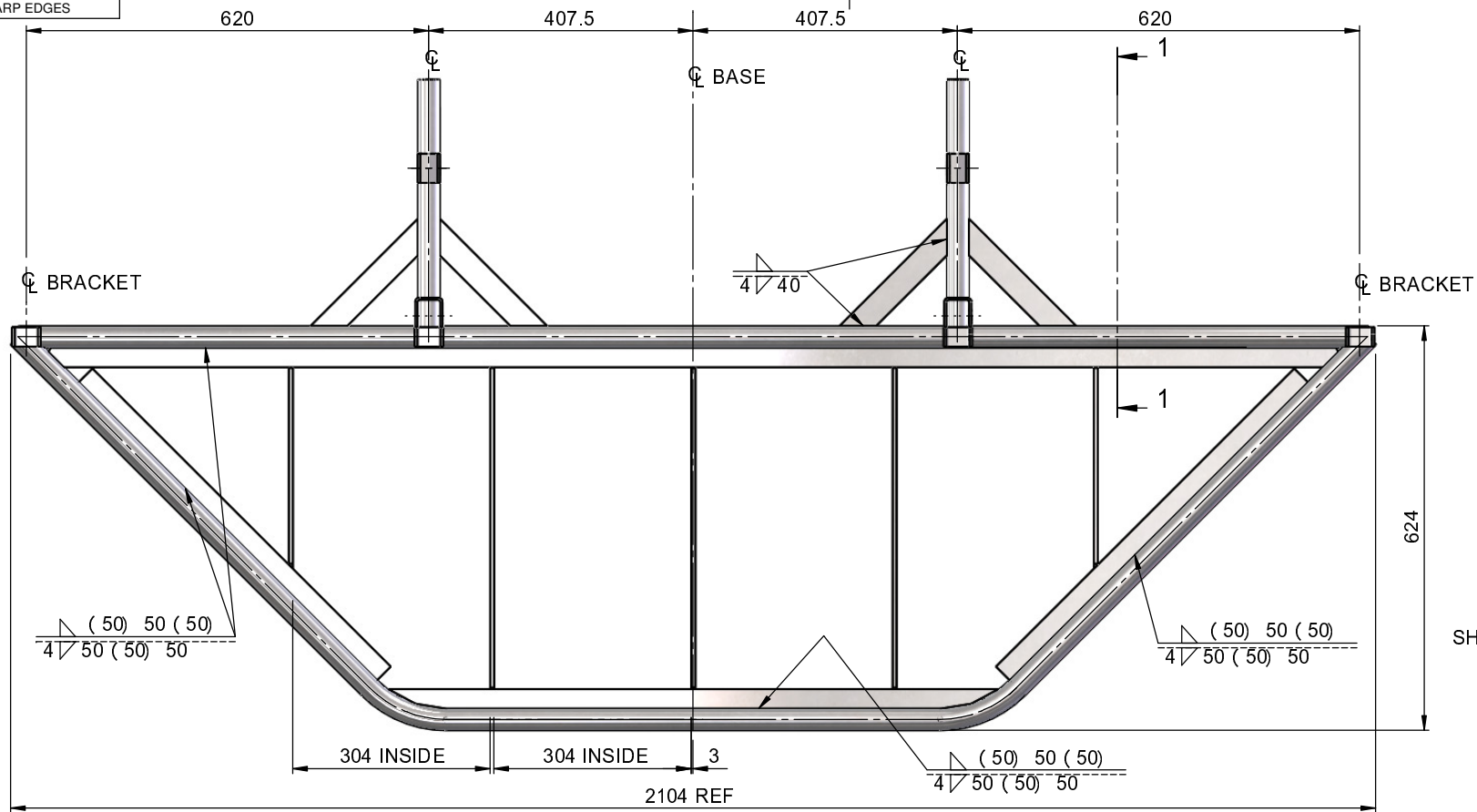

0	29/3/12	ISSUED FOR MANUFACTURE	GC		
P2	5/12/11	ISSUED FOR APPROVAL	GC		
REV	DATE	DESCRIPTION	DRN	CHKD	APPR

TITLE: **BARRIER BASE  
FABRICATION SHT 2**

UNLESS STATED OTHERWISE		
GENERAL TOLERANCES:		
FABRICATION	UP TO 1000mm	+/- 2mm
	1001mm & ABOVE	+/- 3mm
ANGULAR	+/- 0.5 DEGREE	
WEIGHT	+/- 10% (DUE TO MATERIAL PROPERTIES & TOLERANCES)	

NAME	SIGNATURE	DATE
G. CRICK		18/11/11
CHK'D		
FINISH:	NONE	

MATERIAL:  
**CARBON STEEL**

**ZNDDE**

Dwg/Stock No. **ZND501-1 - FAB SHT 2**

Revision **0**

THE COMPANY RETAIN THE RIGHT TO PERIODICALLY ALTER INFORMATION WITHIN THIS DRAWING SHEET AND WILL ATTEMPT TO NOTIFY ALL PARTIES CONCERNED OF ANY CHANGES AND THE INFORMATION ON THIS SHEET SHOULD NOT BE REPRODUCED WITHOUT THEIR WRITTEN CONSENT.

ALL DIMENSIONS IN MILLIMETRES  
REMOVE ALL SHARP EDGES

THIRD ANGLE PROJECTION  
DO NOT SCALE DRAWING

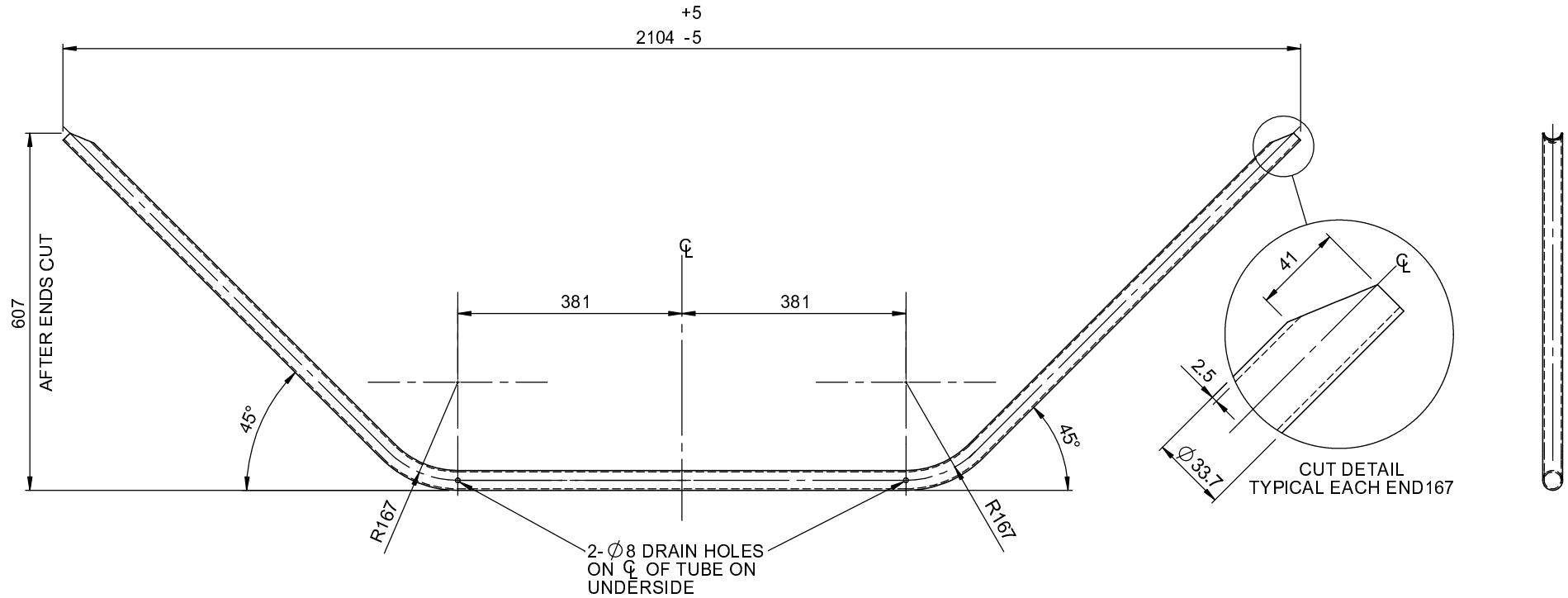

0	29/3/12	ISSUED FOR MANUFACTURE	GC		
P2	18/11/11	ISSUED FOR APPROVAL	GC		
REV	DATE	DESCRIPTION	DRN	CHKD	APPR

TITLE: **BARRIER BASE BENT TUBE**

UNLESS STATED OTHERWISE		
GENERAL TOLERANCES:		
FABRICATION	UP TO 1000mm	+/- 2mm
	1001mm & ABOVE	+/- 3mm
ANGULAR	+/- 0.5 DEGREE	
WEIGHT	+/- 10% (DUE TO MATERIAL PROPERTIES & TOLERANCES)	

DRAWN	NAME	SIGNATURE	DATE
CHK'D	G. CRICK		18/11/11
FINISH: NONE			

MATERIAL: CARBON STEEL



Dwg/Stock No.	Revision
ZNN501-1-1	0

THE COMPANY RETAIN THE RIGHT TO PERIODICALLY ALTER INFORMATION WITHIN THIS DRAWING SHEET AND WILL ATTEMPT TO NOTIFY ALL PARTIES CONCERNED OF ANY CHANGES AND THE INFORMATION ON THIS SHEET SHOULD NOT BE REPRODUCED WITHOUT THEIR WRITTEN CONSENT.

ALL DIMENSIONS IN MILLIMETRES  
REMOVE ALL SHARP EDGES

THIRD ANGLE PROJECTION  
DO NOT SCALE DRAWING

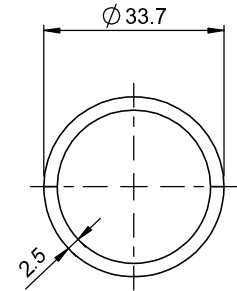
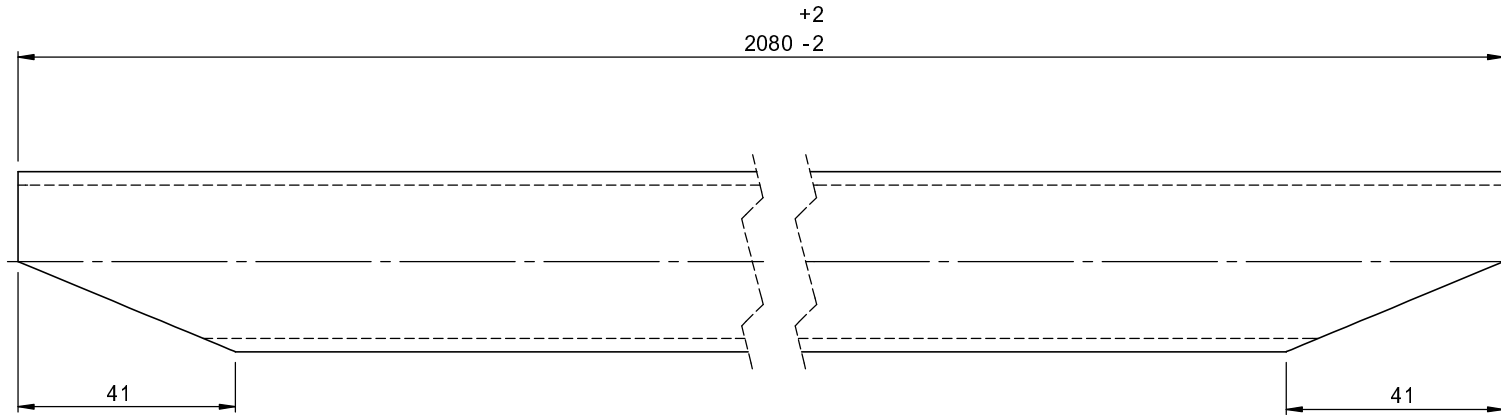

0	29/3/12	ISSUED FOR MANUFACTURE	GC		
P2	5/12/11	ISSUED FOR APPROVAL	GC		
REV	DATE	DESCRIPTION	DRN	CHKD	APPR

TITLE: **BARRIER BASE  
STRAIGHT TUBE**

UNLESS STATED OTHERWISE		
GENERAL TOLERANCES:		
FABRICATION	UP TO 1000mm	+/- 2mm
	1001mm & ABOVE	+/- 3mm
ANGULAR	+/- 0.5 DEGREE	
WEIGHT	+/- 10% (DUE TO MATERIAL PROPERTIES & TOLERANCES)	

	NAME	SIGNATURE	DATE
DRAWN	G. CRICK		18/11/11
CHK'D			
FINISH: NONE			

MATERIAL: CARBON STEEL



Dwg/Stock No.	Revision
<b>ZND501-1-2</b>	<b>0</b>

THE COMPANY RETAIN THE RIGHT TO PERIODICALLY ALTER INFORMATION WITHIN THIS DRAWING SHEET AND WILL ATTEMPT TO NOTIFY ALL PARTIES CONCERNED OF ANY CHANGES AND THE INFORMATION ON THIS SHEET SHOULD NOT BE REPRODUCED WITHOUT THEIR WRITTEN CONSENT.

1  
2  
3  
4  
5  
6  
7  
8

ALL DIMENSIONS IN MILLIMETRES  
REMOVE ALL SHARP EDGES

THIRD ANGLE PROJECTION  
DO NOT SCALE DRAWING

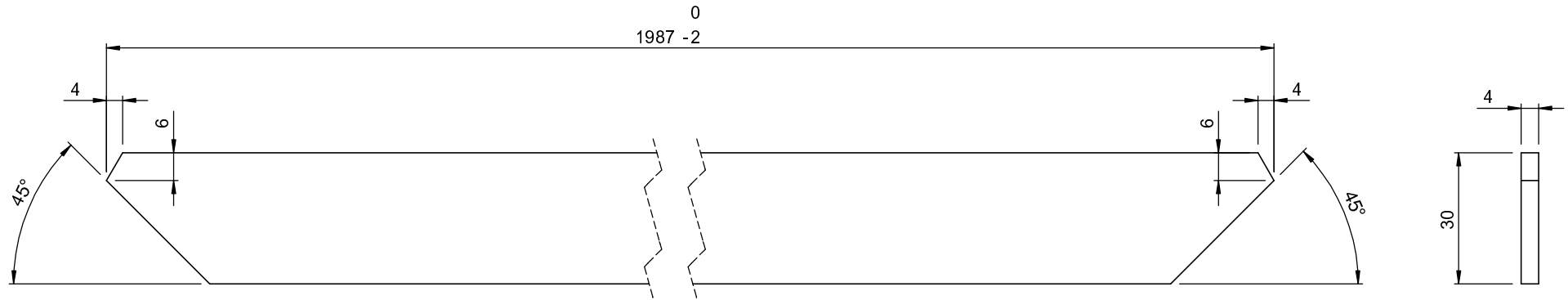

0	29/3/12	ISSUED FOR MANUFACTURE	GC		
P2	5/12/11	ISSUED FOR APPROVAL	GC		
REV	DATE	DESCRIPTION	DRN	CHKD	APPR

TITLE:  
**BARRIER BASE  
FLOOR PLATE SUPPORT 1**

UNLESS STATED OTHERWISE		
GENERAL TOLERANCES:		
FABRICATION	UP TO 1000mm	+/- 2mm
	1001mm & ABOVE	+/- 3mm
ANGULAR	+/- 0.5 DEGREE	
WEIGHT	+/- 10% (DUE TO MATERIAL PROPERTIES & TOLERANCES)	

NAME	SIGNATURE	DATE
G. CRICK		18/11/11
CHK'D		
FINISH:		
NONE		

MATERIAL:  
**CARBON STEEL**



Dwg/Stock No.	Revision
<b>ZND501-1-3</b>	<b>0</b>

THE COMPANY RETAIN THE RIGHT TO PERIODICALLY ALTER INFORMATION WITHIN THIS DRAWING SHEET AND WILL ATTEMPT TO NOTIFY ALL PARTIES CONCERNED OF ANY CHANGES AND THE INFORMATION ON THIS SHEET SHOULD NOT BE REPRODUCED WITHOUT THEIR WRITTEN CONSENT.

ALL DIMENSIONS IN MILLIMETRES  
REMOVE ALL SHARP EDGES

THIRD ANGLE PROJECTION  
DO NOT SCALE DRAWING

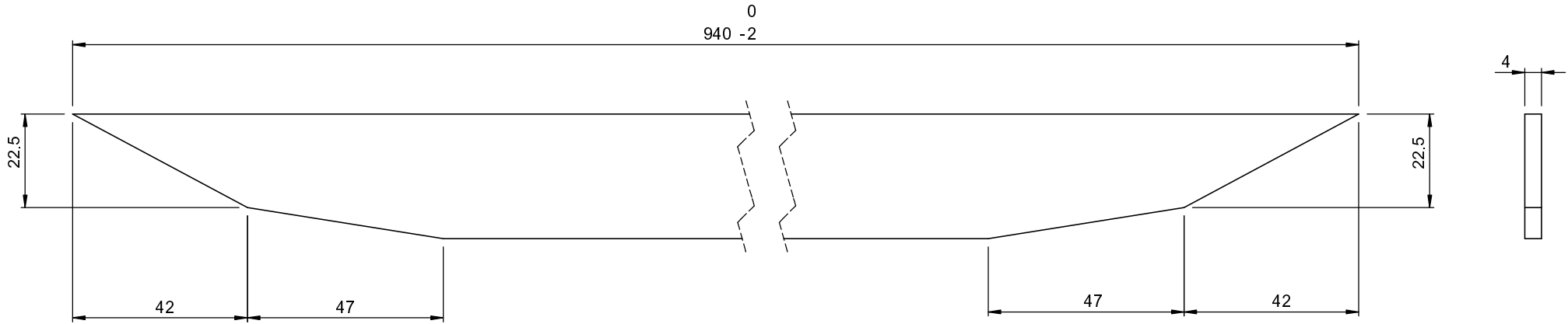

0	29/3/12	ISSUED FOR MANUFACTURE	GC		
P2	5/12/11	ISSUED FOR APPROVAL	GC		
REV	DATE	DESCRIPTION	DRN	CHKD	APPR

TITLE: **BARRIER BASE  
FLOOR PLATE SUPPORT 3**

UNLESS STATED OTHERWISE		
GENERAL TOLERANCES:		
FABRICATION	UP TO 1000mm	+/- 2mm
	1001mm & ABOVE	+/- 3mm
ANGULAR	+/- 0.5 DEGREE	
WEIGHT	+/- 10% (DUE TO MATERIAL PROPERTIES & TOLERANCES)	

NAME	SIGNATURE	DATE
G. CRICK		5/12/11
CHK'D		
FINISH:		
NONE		

MATERIAL:  
**CARBON STEEL**



Dwg/Stock No. **ZND501-1-5** Revision **0**

THE COMPANY RETAIN THE RIGHT TO PERIODICALLY ALTER INFORMATION WITHIN THIS DRAWING SHEET AND WILL ATTEMPT TO NOTIFY ALL PARTIES CONCERNED OF ANY CHANGES AND THE INFORMATION ON THIS SHEET SHOULD NOT BE REPRODUCED WITHOUT THEIR WRITTEN CONSENT.



ALL DIMENSIONS IN MILLIMETRES  
REMOVE ALL SHARP EDGES

THIRD ANGLE PROJECTION  
DO NOT SCALE DRAWING

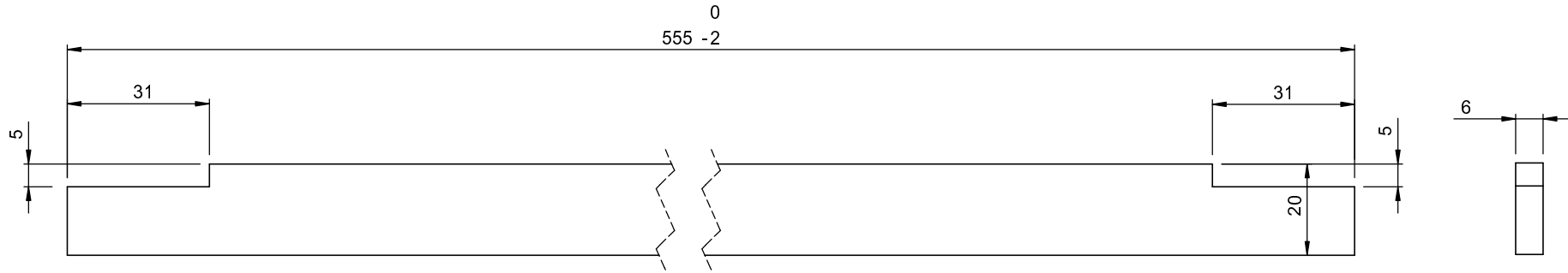

0	29/3/12	ISSUED FOR MANUFACTURE	GC	.	.
P2	5/12/11	ISSUED FOR APPROVAL	GC	.	.
REV	DATE	DESCRIPTION	DRN	CHKD	APPR

TITLE: **BARRIER BASE  
FLOOR PLATE SUPPORT 4**

UNLESS STATED OTHERWISE		
GENERAL TOLERANCES:		
FABRICATION	UP TO 1000mm	+/- 2mm
	1001mm & ABOVE	+/- 3mm
ANGULAR	+/- 0.5 DEGREE	
WEIGHT	+/- 10% (DUE TO MATERIAL PROPERTIES & TOLERANCES)	

NAME	SIGNATURE	DATE
G. CRICK		18/11/11
CHK'D		
FINISH: NONE		

MATERIAL: CARBON STEEL



Dwg/Stock No.	Revision
ZND501-1-6	0

THE COMPANY RETAIN THE RIGHT TO PERIODICALLY ALTER INFORMATION WITHIN THIS DRAWING SHEET AND WILL ATTEMPT TO NOTIFY ALL PARTIES CONCERNED OF ANY CHANGES AND THE INFORMATION ON THIS SHEET SHOULD NOT BE REPRODUCED WITHOUT THEIR WRITTEN CONSENT.

1  
2  
3  
4  
5  
6  
7  
8

ALL DIMENSIONS IN MILLIMETRES  
REMOVE ALL SHARP EDGES

THIRD ANGLE PROJECTION  
DO NOT SCALE DRAWING

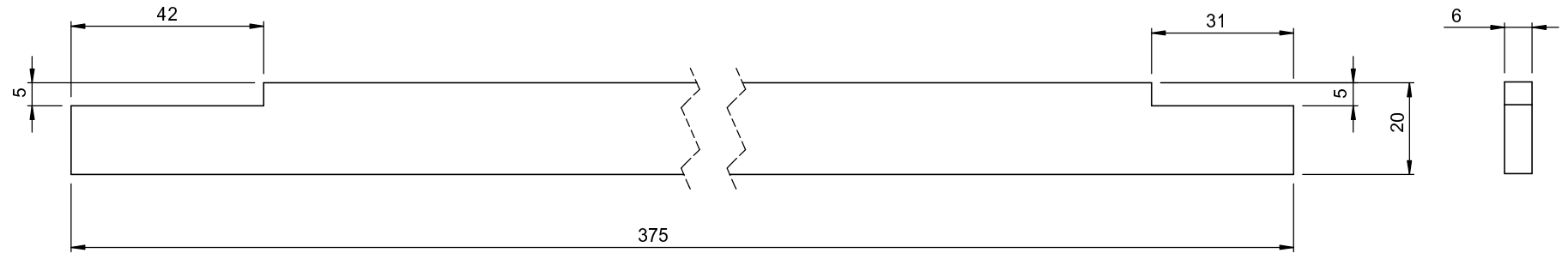

0	29/3/12	ISSUED FOR MANUFACTURE	GC	.	.
P2	5/12/11	ISSUED FOR APPROVAL	GC	.	.
REV	DATE	DESCRIPTION	DRN	CHKD	APPR

TITLE: **BARRIER BASE  
FLOOR SUPPORT 5**

UNLESS STATED OTHERWISE		
GENERAL TOLERANCES:		
FABRICATION	UP TO 1000mm	+/- 2mm
	1001mm & ABOVE	+/- 3mm
ANGULAR	+/- 0.5 DEGREE	
WEIGHT	+/- 10% (DUE TO MATERIAL PROPERTIES & TOLERANCES)	

NAME	SIGNATURE	DATE
G. CRICK		5/12/11
CHK'D		
FINISH:		
NONE		

MATERIAL:  
**CARBON STEEL**



Dwg/Stock No.	Revision
<b>ZND501-1-7</b>	<b>0</b>

THE COMPANY RETAIN THE RIGHT TO PERIODICALLY ALTER INFORMATION WITHIN THIS DRAWING SHEET AND WILL ATTEMPT TO NOTIFY ALL PARTIES CONCERNED OF ANY CHANGES AND THE INFORMATION ON THIS SHEET SHOULD NOT BE REPRODUCED WITHOUT THEIR WRITTEN CONSENT.

ALL DIMENSIONS IN MILLIMETRES  
REMOVE ALL SHARP EDGES

THIRD ANGLE PROJECTION  
DO NOT SCALE DRAWING

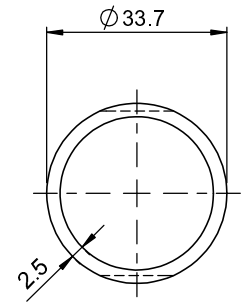
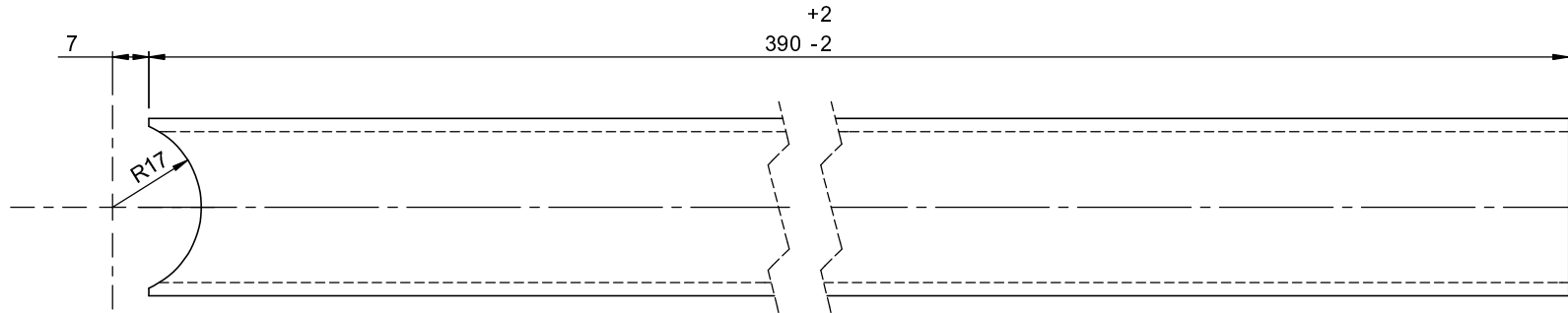

0	29/3/12	ISSUED FOR MANUFACTURE	GC		
P2	5/12/11	ISSUED FOR APPROVAL	GC		
REV	DATE	DESCRIPTION	DRN	CHKD	APPR

TITLE: **BARRIER BASE  
LEG TUBE**

UNLESS STATED OTHERWISE		
GENERAL TOLERANCES:		
FABRICATION	UP TO 1000mm	+/- 2mm
	1001mm & ABOVE	+/- 3mm
ANGULAR	+/- 0.5 DEGREE	
WEIGHT	+/- 10% (DUE TO MATERIAL PROPERTIES & TOLERANCES)	

DRAWN	NAME	SIGNATURE	DATE
CHK'D	G. CRICK		18/11/11
FINISH:			
NONE			

MATERIAL:  
**CARBON STEEL**



Dwg/Stock No. **ZND501-1-8** Revision **0**

THE COMPANY RETAIN THE RIGHT TO PERIODICALLY ALTER INFORMATION WITHIN THIS DRAWING SHEET AND WILL ATTEMPT TO NOTIFY ALL PARTIES CONCERNED OF ANY CHANGES AND THE INFORMATION ON THIS SHEET SHOULD NOT BE REPRODUCED WITHOUT THEIR WRITTEN CONSENT.

1  
2  
3  
4  
5  
6  
7  
8

ALL DIMENSIONS IN MILLIMETRES  
REMOVE ALL SHARP EDGES

THIRD ANGLE PROJECTION  
DO NOT SCALE DRAWING

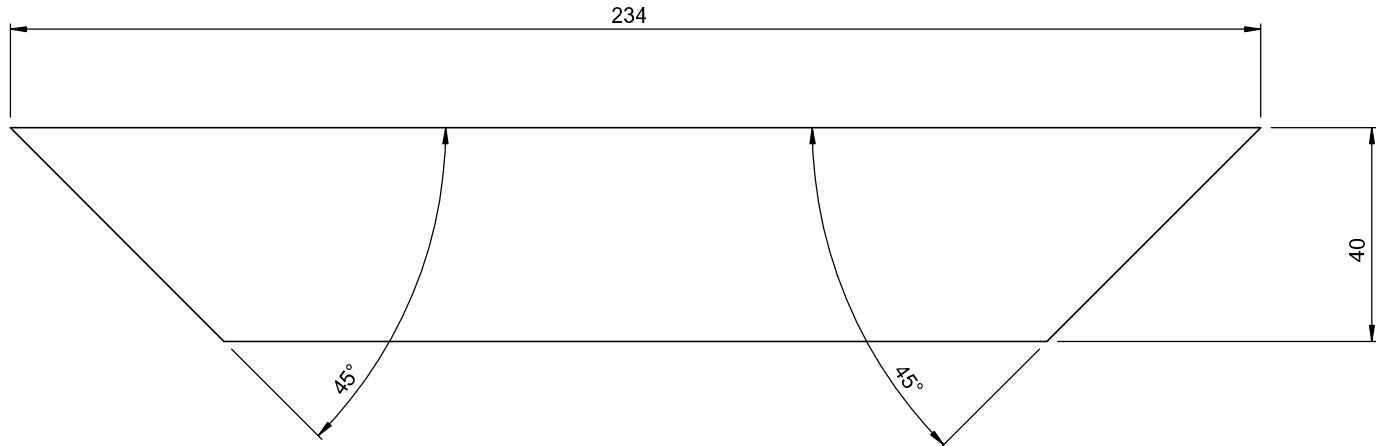

0	29/3/12	ISSUED FOR MANUFACTURE	GC		
P2	5/12/11	ISSUED FOR APPROVAL	GC		
REV	DATE	DESCRIPTION	DRN	CHKD	APPR

TITLE: **BARRIER BASE BRACE**

UNLESS STATED OTHERWISE		
GENERAL TOLERANCES:		
FABRICATION	UP TO 1000mm	+/- 2mm
	1001mm & ABOVE	+/- 3mm
ANGULAR	+/- 0.5 DEGREE	
WEIGHT	+/- 10% (DUE TO MATERIAL PROPERTIES & TOLERANCES)	

DRAWN	NAME	SIGNATURE	DATE
CHK'D	G. CRICK		18/11/11
FINISH:			
NONE			

MATERIAL:  
**CARBON STEEL**



Dwg/Stock No. **ZND501-1-9** Revision **0**

THE COMPANY RETAIN THE RIGHT TO PERIODICALLY ALTER INFORMATION WITHIN THIS DRAWING SHEET AND WILL ATTEMPT TO NOTIFY ALL PARTIES CONCERNED OF ANY CHANGES AND THE INFORMATION ON THIS SHEET SHOULD NOT BE REPRODUCED WITHOUT THEIR WRITTEN CONSENT.

1  
2  
3  
4  
5  
6  
7  
8

ALL DIMENSIONS IN MILLIMETRES  
REMOVE ALL SHARP EDGES

THIRD ANGLE PROJECTION  
DO NOT SCALE DRAWING

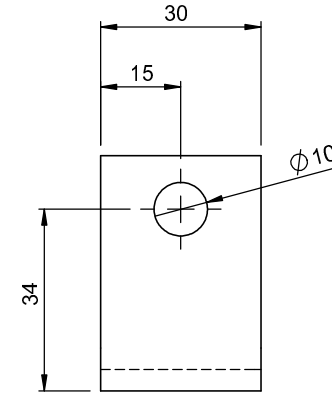
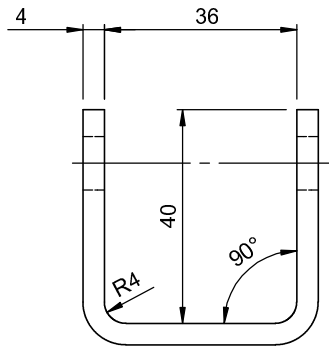

0	29/3/12	ISSUED FOR MANUFACTURE	GC		
P2	5/12/11	ISSUED FOR APPROVAL	GC		
REV	DATE	DESCRIPTION	DRN	CHKD	APPR

TITLE: **BARRIER BASE PIVOT BRACKET**

UNLESS STATED OTHERWISE		
GENERAL TOLERANCES:		
FABRICATION	UP TO 1000mm	+/- 2mm
	1001mm & ABOVE	+/- 3mm
ANGULAR	+/- 0.5 DEGREE	
WEIGHT	+/- 10% (DUE TO MATERIAL PROPERTIES & TOLERANCES)	

NAME	SIGNATURE	DATE
G. CRICK		18/11/11
CHK'D		
FINISH: NONE		

MATERIAL: CARBON STEEL



Dwg/Stock No.	Revision
<b>ZND501-1-10</b>	<b>0</b>

THE COMPANY RETAIN THE RIGHT TO PERIODICALLY ALTER INFORMATION WITHIN THIS DRAWING SHEET AND WILL ATTEMPT TO NOTIFY ALL PARTIES CONCERNED OF ANY CHANGES AND THE INFORMATION ON THIS SHEET SHOULD NOT BE REPRODUCED WITHOUT THEIR WRITTEN CONSENT.

ALL DIMENSIONS IN MILLIMETRES  
REMOVE ALL SHARP EDGES

THIRD ANGLE PROJECTION  
DO NOT SCALE DRAWING

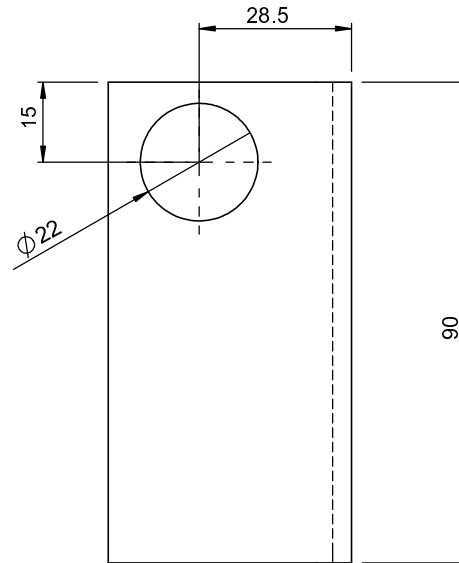
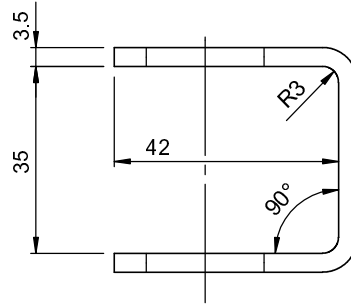

0	29/3/12	ISSUED FOR MANUFACTURE	GC		
P2	5/12/11	ISSUED FOR APPROVAL	GC		
REV	DATE	DESCRIPTION	DRN	CHKD	APPR

TITLE: **BARRIER BASE LOCKING BRACKET**

UNLESS STATED OTHERWISE		
GENERAL TOLERANCES:		
FABRICATION	UP TO 1000mm	+/- 2mm
	1001mm & ABOVE	+/- 3mm
ANGULAR	+/- 0.5 DEGREE	
WEIGHT	+/- 10% (DUE TO MATERIAL PROPERTIES & TOLERANCES)	

NAME	SIGNATURE	DATE
G. CRICK		18/11/11
CHK'D		
FINISH:		
NONE		

MATERIAL:  
**CARBON STEEL**



Dwg/Stock No.	Revision
<b>ZND501-1-11</b>	<b>0</b>

THE COMPANY RETAIN THE RIGHT TO PERIODICALLY ALTER INFORMATION WITHIN THIS DRAWING SHEET AND WILL ATTEMPT TO NOTIFY ALL PARTIES CONCERNED OF ANY CHANGES AND THE INFORMATION ON THIS SHEET SHOULD NOT BE REPRODUCED WITHOUT THEIR WRITTEN CONSENT.

1  
2  
3  
4  
5  
6  
7  
8

ALL DIMENSIONS IN MILLIMETRES  
REMOVE ALL SHARP EDGES

THIRD ANGLE PROJECTION  
DO NOT SCALE DRAWING

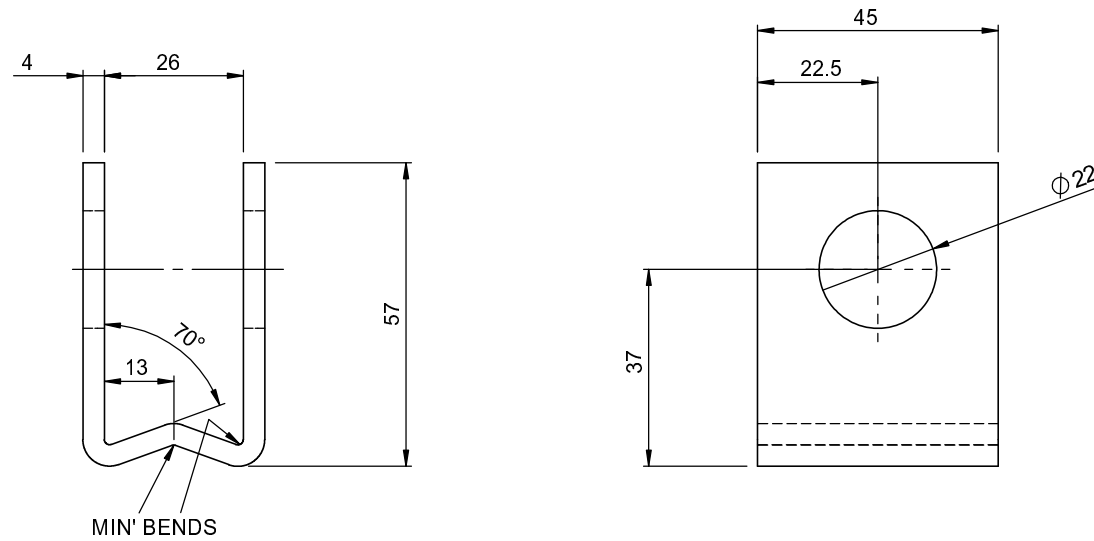

0	29/3/12	ISSUED FOR MANUFACTURE	GC	.	.
P2	5/12/11	ISSUED FOR APPROVAL	GC	.	.
REV	DATE	DESCRIPTION	DRN	CHKD	APPR

TITLE: **BARRIER BASE  
LEG BRACKET**

UNLESS STATED OTHERWISE		
GENERAL TOLERANCES:		
FABRICATION	UP TO 1000mm	+/- 2mm
	1001mm & ABOVE	+/- 3mm
ANGULAR	+/- 0.5 DEGREE	
WEIGHT	+/- 10% (DUE TO MATERIAL PROPERTIES & TOLERANCES)	

NAME	SIGNATURE	DATE
G. CRICK		18/11/11
CHK'D		
FINISH:		
NONE		

MATERIAL:  
**CARBON STEEL**



Dwg/Stock No.	Revision
<b>ZND501-1-12</b>	<b>0</b>

THE COMPANY RETAIN THE RIGHT TO PERIODICALLY ALTER INFORMATION WITHIN THIS DRAWING SHEET AND WILL ATTEMPT TO NOTIFY ALL PARTIES CONCERNED OF ANY CHANGES AND THE INFORMATION ON THIS SHEET SHOULD NOT BE REPRODUCED WITHOUT THEIR WRITTEN CONSENT.

ALL DIMENSIONS IN MILLIMETRES  
REMOVE ALL SHARP EDGES

THIRD ANGLE PROJECTION  
DO NOT SCALE DRAWING

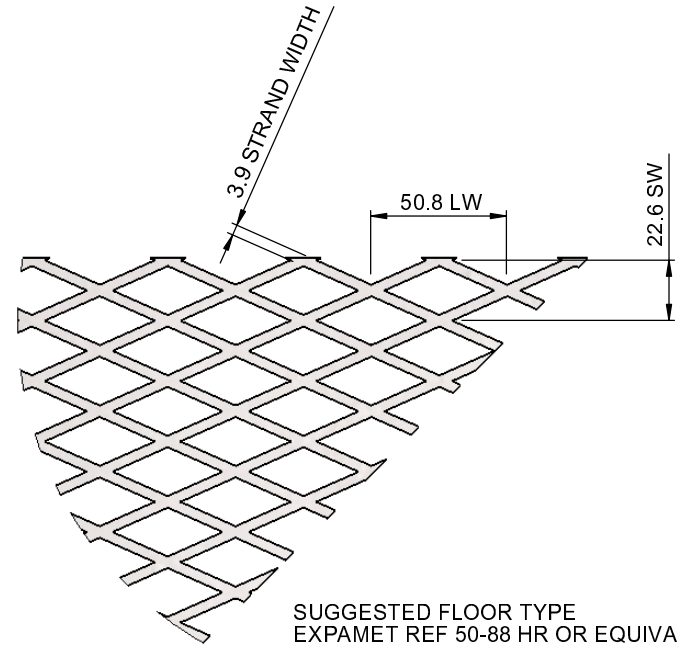
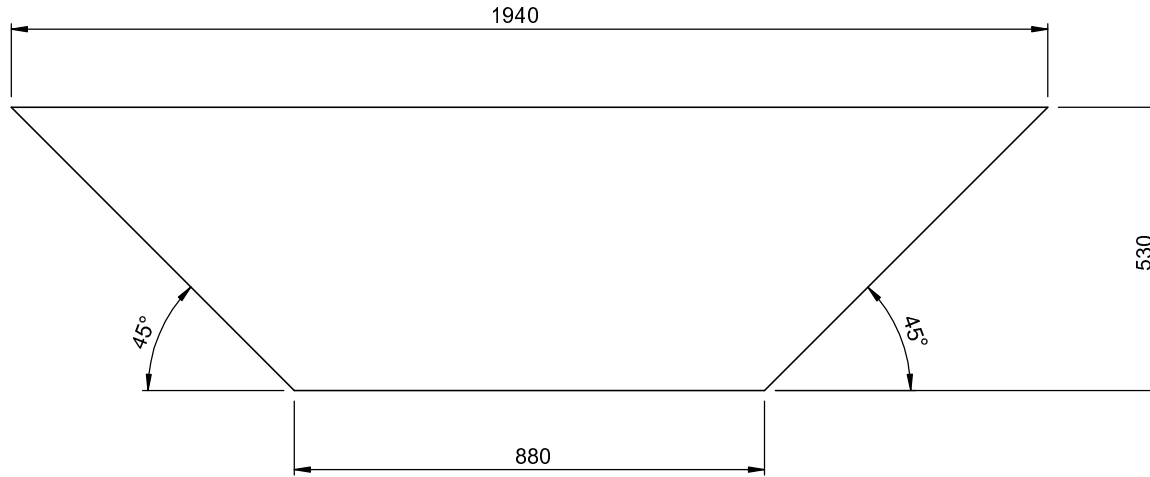

SUGGESTED FLOOR TYPE  
EXPAMET REF 50-88 HR OR EQUIVALENT  
APPROX 3mm THICK AND WEIGHT = 8.09 Kg/m<sup>2</sup>

0	29/3/12	ISSUED FOR MANUFACTURE	GC		
P2	5/12/11	ISSUED FOR APPROVAL	GC		
REV	DATE	DESCRIPTION	DRN	CHKD	APPR

TITLE: **BARRIER BASE  
MESH FLOOR PLATE**

UNLESS STATED OTHERWISE		
GENERAL TOLERANCES:		
FABRICATION	UP TO 1000mm	+/- 2mm
	1001mm & ABOVE	+/- 3mm
ANGULAR	+/- 0.5 DEGREE	
WEIGHT	+/- 10% (DUE TO MATERIAL PROPERTIES & TOLERANCES)	

DRAWN	NAME	SIGNATURE	DATE
CHK'D	G. CRICK		18/11/11
FINISH:	NONE		

MATERIAL:  
**CARBON STEEL**



Dwg/Stock No.	Revision
<b>ZND501-1-13</b>	<b>0</b>

THE COMPANY RETAIN THE RIGHT TO PERIODICALLY ALTER INFORMATION WITHIN THIS DRAWING SHEET AND WILL ATTEMPT TO NOTIFY ALL PARTIES CONCERNED OF ANY CHANGES AND THE INFORMATION ON THIS SHEET SHOULD NOT BE REPRODUCED WITHOUT THEIR WRITTEN CONSENT.



ALL DIMENSIONS IN MILLIMETRES  
REMOVE ALL SHARP EDGES

THIRD ANGLE PROJECTION  
DO NOT SCALE DRAWING

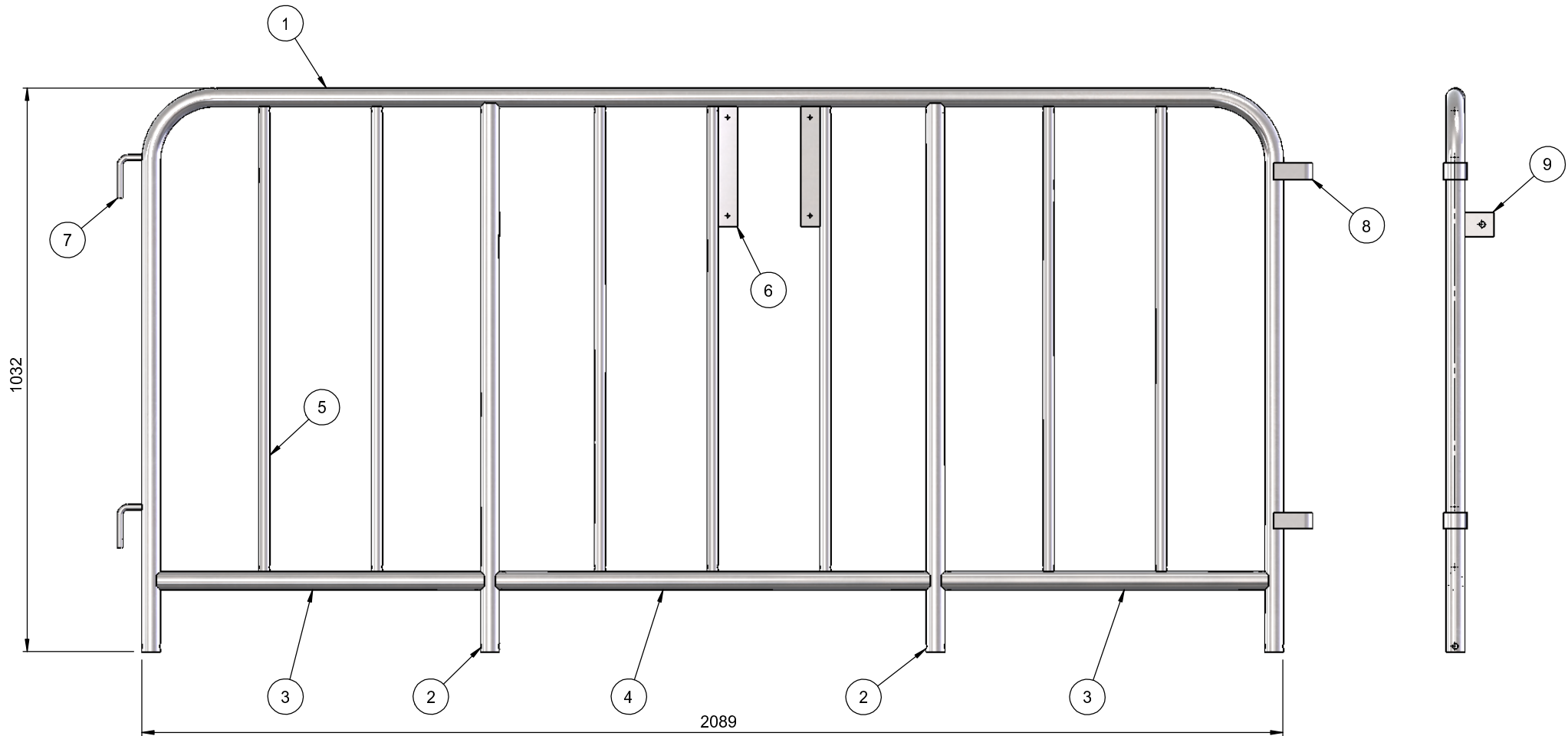

ITEM No.	PART No.	DESCRIPTION	QTY
1	ZND501-2-1	BARRIER FRAME	1
2	ZND501-2-2	VERTICAL TUBE	2
3	ZND501-2-3	HORIZONTAL TUBE	2
4	ZND501-2-4	HORIZONTAL TUBE	1
5	ZND501-2-5	VERTICAL POST	7
6	ZND501-2-6	SIGN PLATE	2
7	ZND501-2-7	HOOK	2
8	ZND501-2-8	EYE	2
9	ZND501-2-9	LEG BRACKET	2

REV	DATE	DESCRIPTION	DRN	CHKD	APPR
0	29/3/12	ISSUED FOR MANUFACTURE	GC		
P2	6/12/11	ISSUED FOR APPROVAL	GC		

TITLE: **BARRIER FABRICATION SHT 1**

NAME	SIGNATURE	DATE	MATERIAL:
G. CRICK		18/11/11	CARBON STEEL
CHK'D			
FINISH:	HOT DIPPED GALVANISED		



Dwg/Stock No. **ZND501-2 - FAB SHT 1** Revision **0**

UNLESS STATED OTHERWISE		
GENERAL TOLERANCES:		
FABRICATION	UP TO 1000mm	+/- 2mm
	1001mm & ABOVE	+/- 3mm
ANGULAR	+/- 0.5 DEGREE	
WEIGHT	+/- 10% (DUE TO MATERIAL PROPERTIES & TOLERANCES)	

THE COMPANY RETAIN THE RIGHT TO PERIODICALLY ALTER INFORMATION WITHIN THIS DRAWING SHEET AND WILL ATTEMPT TO NOTIFY ALL PARTIES CONCERNED OF ANY CHANGES AND THE INFORMATION ON THIS SHEET SHOULD NOT BE REPRODUCED WITHOUT THEIR WRITTEN CONSENT.

ALL DIMENSIONS IN MILLIMETRES  
REMOVE ALL SHARP EDGES

THIRD ANGLE PROJECTION  
DO NOT SCALE DRAWING

SECTION 1-1

2089 REF

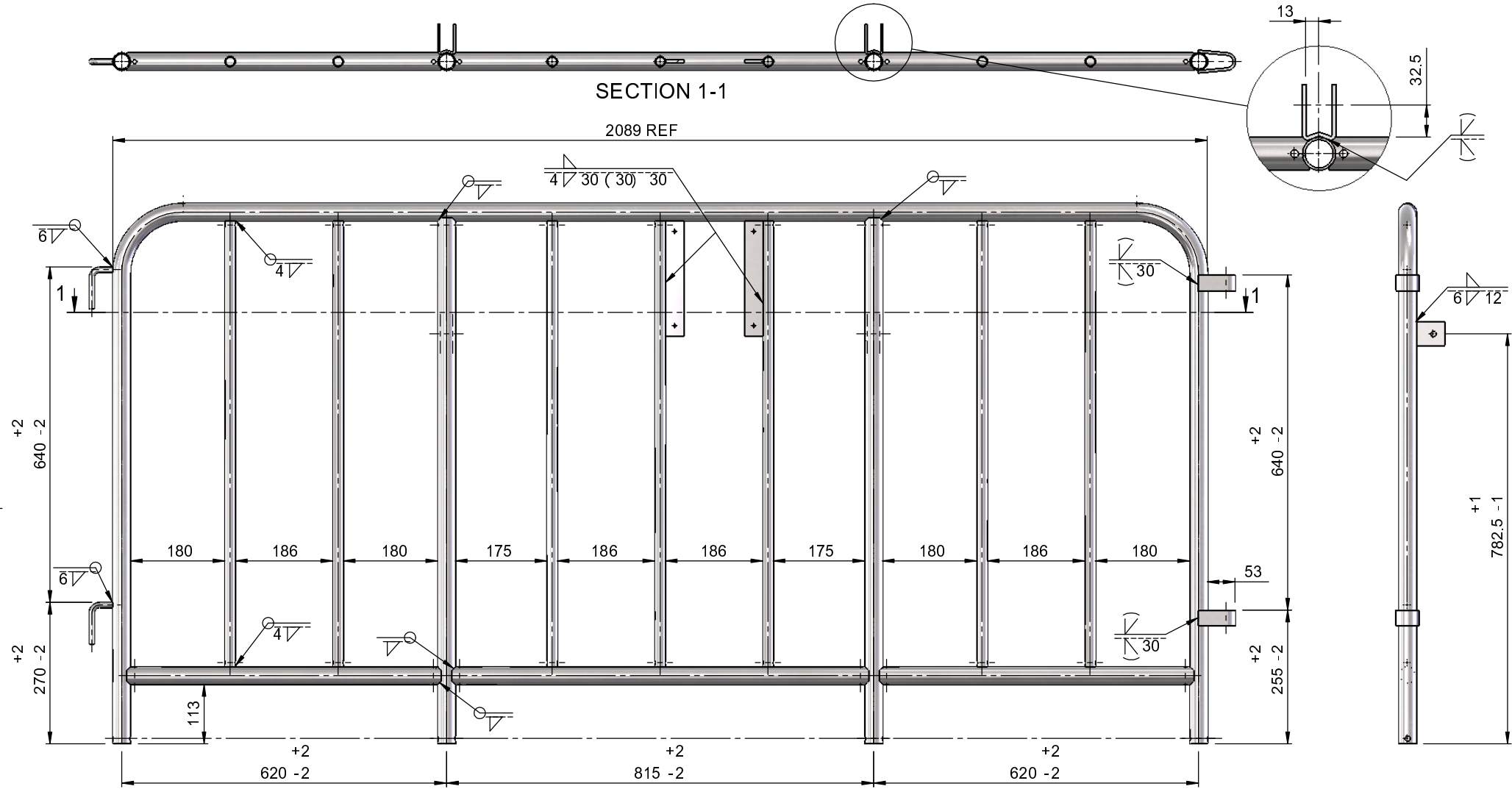

0	29/3/12	ISSUED FOR MANUFACTURE	GC		
P2	6/12/11	ISSUED FOR APPROVAL	GC		
REV	DATE	DESCRIPTION	DRN	CHKD	APPR

TITLE: **BARRIER FABRICATION SHT 2**

UNLESS STATED OTHERWISE		
GENERAL TOLERANCES:		
FABRICATION	UP TO 1000mm	+/- 2mm
	1001mm & ABOVE	+/- 3mm
ANGULAR	+/- 0.5 DEGREE	
WEIGHT	+/- 10% (DUE TO MATERIAL PROPERTIES & TOLERANCES)	

NAME	SIGNATURE	DATE
G. CRICK		18/11/11
CHK'D		
FINISH: NONE		

MATERIAL: CARBON STEEL



Dwg/Stock No. **ZND501-2 - FAB SHT 2** Revision **0**

THE COMPANY RETAIN THE RIGHT TO PERIODICALLY ALTER INFORMATION WITHIN THIS DRAWING SHEET AND WILL ATTEMPT TO NOTIFY ALL PARTIES CONCERNED OF ANY CHANGES AND THE INFORMATION ON THIS SHEET SHOULD NOT BE REPRODUCED WITHOUT THEIR WRITTEN CONSENT.

ALL DIMENSIONS IN MILLIMETRES  
REMOVE ALL SHARP EDGES

THIRD ANGLE PROJECTION  
DO NOT SCALE DRAWING

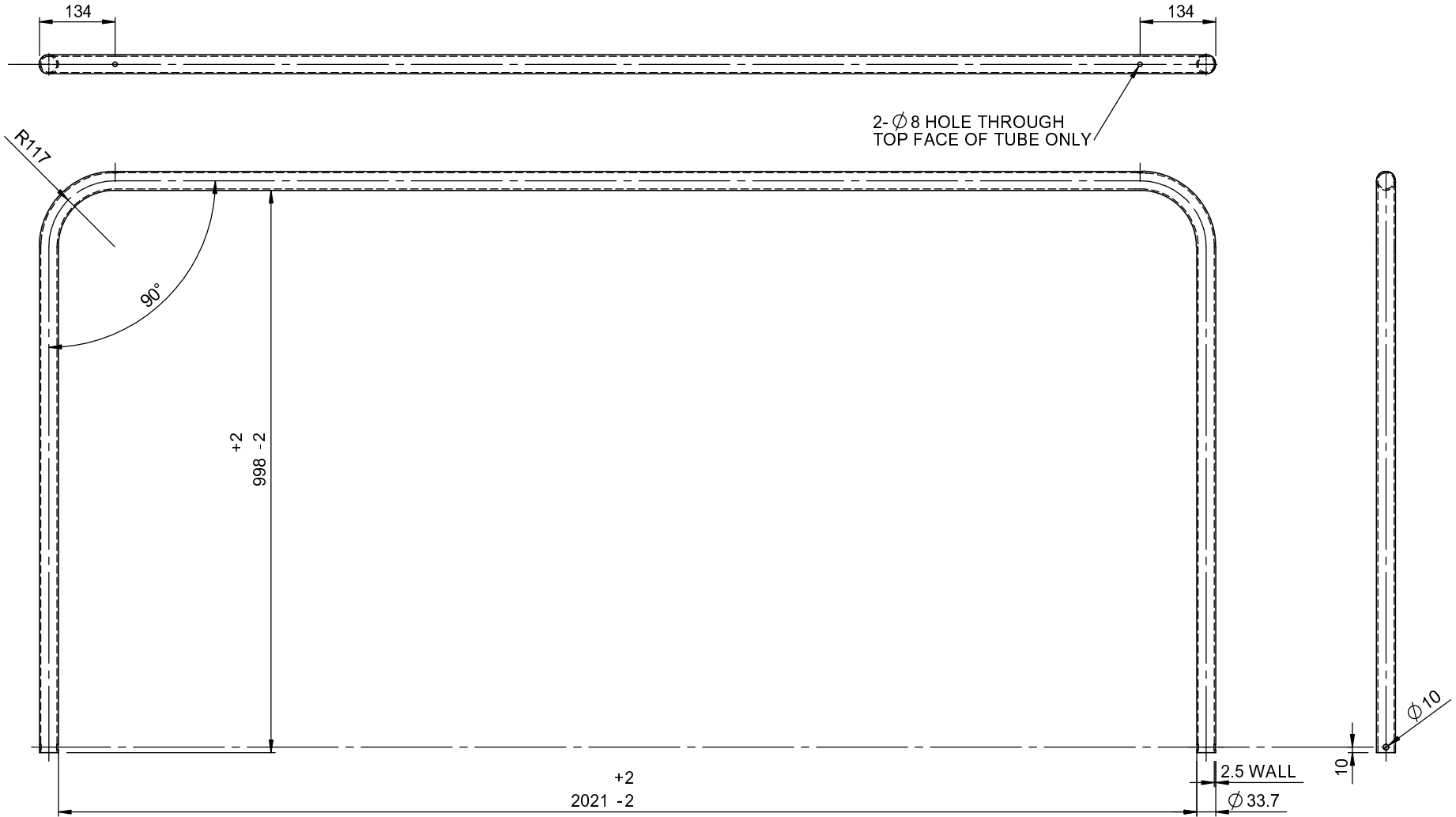

0	29/3/12	ISSUED FOR MANUFACTURE	GC		
P2	6/12/11	ISSUED FOR APPROVAL	GC		
REV	DATE	DESCRIPTION	DRN	CHKD	APPR

TITLE: **BARRIER FRAME**

UNLESS STATED OTHERWISE		
GENERAL TOLERANCES:		
FABRICATION	UP TO 1000mm	+/- 2mm
	1001mm & ABOVE	+/- 3mm
ANGULAR	+/- 0.5 DEGREE	
WEIGHT	+/- 10% (DUE TO MATERIAL PROPERTIES & TOLERANCES)	

NAME	SIGNATURE	DATE
G. CRICK		18/11/11
CHK'D		
FINISH:		
NONE		

MATERIAL:  
**CARBON STEEL**



Dwg/Stock No. **ZND501-2-1** Revision **0**

THE COMPANY RETAIN THE RIGHT TO PERIODICALLY ALTER INFORMATION WITHIN THIS DRAWING SHEET AND WILL ATTEMPT TO NOTIFY ALL PARTIES CONCERNED OF ANY CHANGES AND THE INFORMATION ON THIS SHEET SHOULD NOT BE REPRODUCED WITHOUT THEIR WRITTEN CONSENT.

1  
2  
3  
4  
5  
6  
7  
8

ALL DIMENSIONS IN MILLIMETRES  
REMOVE ALL SHARP EDGES

THIRD ANGLE PROJECTION  
DO NOT SCALE DRAWING

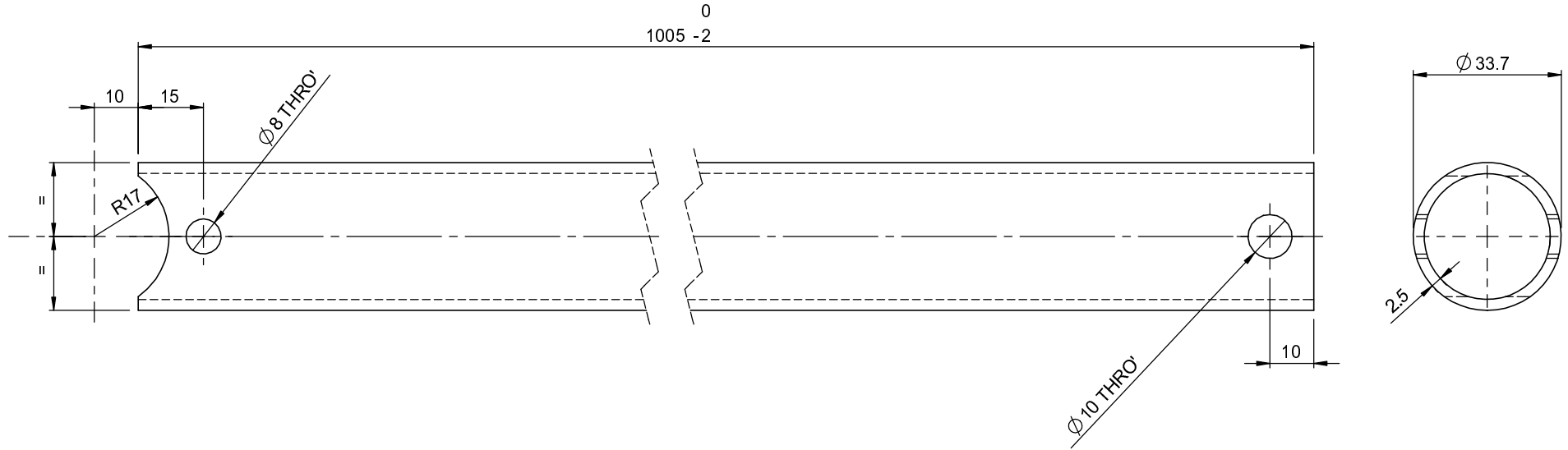

0	29/3/12	ISSUED FOR MANUFACTURE	GC		
P2	6/12/11	ISSUED FOR APPROVAL	GC		
REV	DATE	DESCRIPTION	DRN	CHKD	APPR

TITLE: **BARRIER VERTICAL TUBE**

UNLESS STATED OTHERWISE		
GENERAL TOLERANCES:		
FABRICATION	UP TO 1000mm	+/- 2mm
	1001mm & ABOVE	+/- 3mm
ANGULAR	+/- 0.5 DEGREE	
WEIGHT	+/- 10% (DUE TO MATERIAL PROPERTIES & TOLERANCES)	

DRAWN	NAME	SIGNATURE	DATE
CHK'D	G. CRICK		18/11/11
FINISH: NONE			

MATERIAL: CARBON STEEL



Dwg/Stock No.	Revision
ZND501-2-2	0

THE COMPANY RETAIN THE RIGHT TO PERIODICALLY ALTER INFORMATION WITHIN THIS DRAWING SHEET AND WILL ATTEMPT TO NOTIFY ALL PARTIES CONCERNED OF ANY CHANGES AND THE INFORMATION ON THIS SHEET SHOULD NOT BE REPRODUCED WITHOUT THEIR WRITTEN CONSENT.

ALL DIMENSIONS IN MILLIMETRES  
REMOVE ALL SHARP EDGES

THIRD ANGLE PROJECTION  
DO NOT SCALE DRAWING

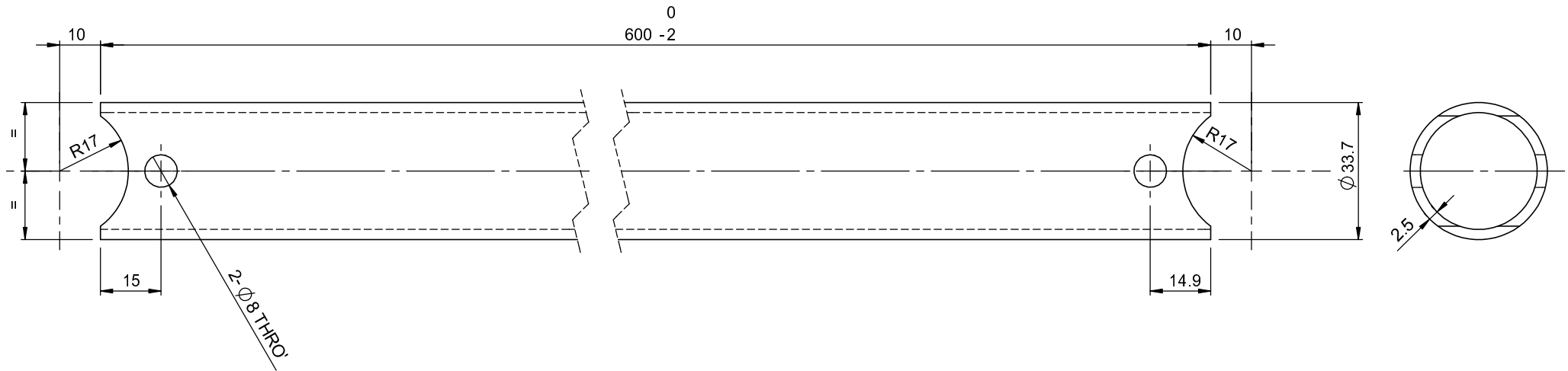

0	29/3/12	ISSUED FOR MANUFACTURE	GC		
P2	6/12/11	ISSUED FOR APPROVAL	GC		
REV	DATE	DESCRIPTION	DRN	CHKD	APPR

TITLE: **BARRIER HORIZONTAL TUBE**

UNLESS STATED OTHERWISE		
GENERAL TOLERANCES:		
FABRICATION	UP TO 1000mm	+/- 2mm
	1001mm & ABOVE	+/- 3mm
ANGULAR	+/- 0.5 DEGREE	
WEIGHT	+/- 10% (DUE TO MATERIAL PROPERTIES & TOLERANCES)	

NAME	SIGNATURE	DATE
G. CRICK		18/11/11
CHK'D		
FINISH: NONE		

MATERIAL: CARBON STEEL



Dwg/Stock No. **ZND501-2-3** Revision **0**

THE COMPANY RETAIN THE RIGHT TO PERIODICALLY ALTER INFORMATION WITHIN THIS DRAWING SHEET AND WILL ATTEMPT TO NOTIFY ALL PARTIES CONCERNED OF ANY CHANGES AND THE INFORMATION ON THIS SHEET SHOULD NOT BE REPRODUCED WITHOUT THEIR WRITTEN CONSENT.

ALL DIMENSIONS IN MILLIMETRES  
REMOVE ALL SHARP EDGES

THIRD ANGLE PROJECTION  
DO NOT SCALE DRAWING

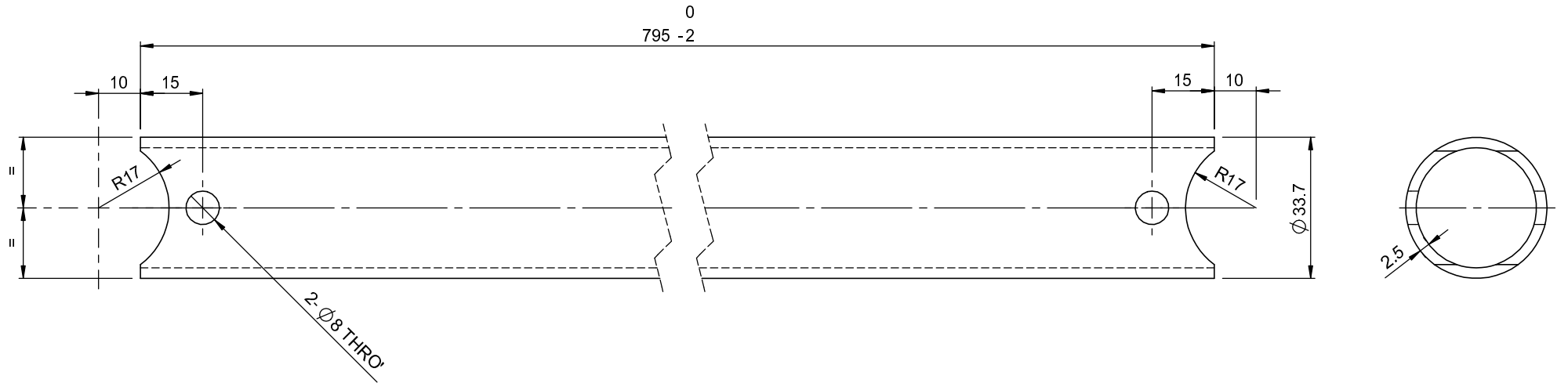

0	29/3/12	ISSUED FOR MANUFACTURE	GC	.	.
P2	6/12/11	ISSUED FOR APPROVAL	GC	.	.
REV	DATE	DESCRIPTION	DRN	CHKD	APPR

TITLE: **BARRIER  
HORIZONTAL TUBE**

UNLESS STATED OTHERWISE		
GENERAL TOLERANCES:		
FABRICATION	UP TO 1000mm	+/- 2mm
	1001mm & ABOVE	+/- 3mm
ANGULAR	+/- 0.5 DEGREE	
WEIGHT	+/- 10% (DUE TO MATERIAL PROPERTIES & TOLERANCES)	

NAME	SIGNATURE	DATE
G. CRICK		18/11/11
CHK'D		
FINISH:		
NONE		

MATERIAL:  
**CARBON STEEL**



Dwg/Stock No.	Revision
<b>ZND501-2-4</b>	<b>0</b>

THE COMPANY RETAIN THE RIGHT TO PERIODICALLY ALTER INFORMATION WITHIN THIS DRAWING SHEET AND WILL ATTEMPT TO NOTIFY ALL PARTIES CONCERNED OF ANY CHANGES AND THE INFORMATION ON THIS SHEET SHOULD NOT BE REPRODUCED WITHOUT THEIR WRITTEN CONSENT.

ALL DIMENSIONS IN MILLIMETRES  
REMOVE ALL SHARP EDGES

THIRD ANGLE PROJECTION  
DO NOT SCALE DRAWING

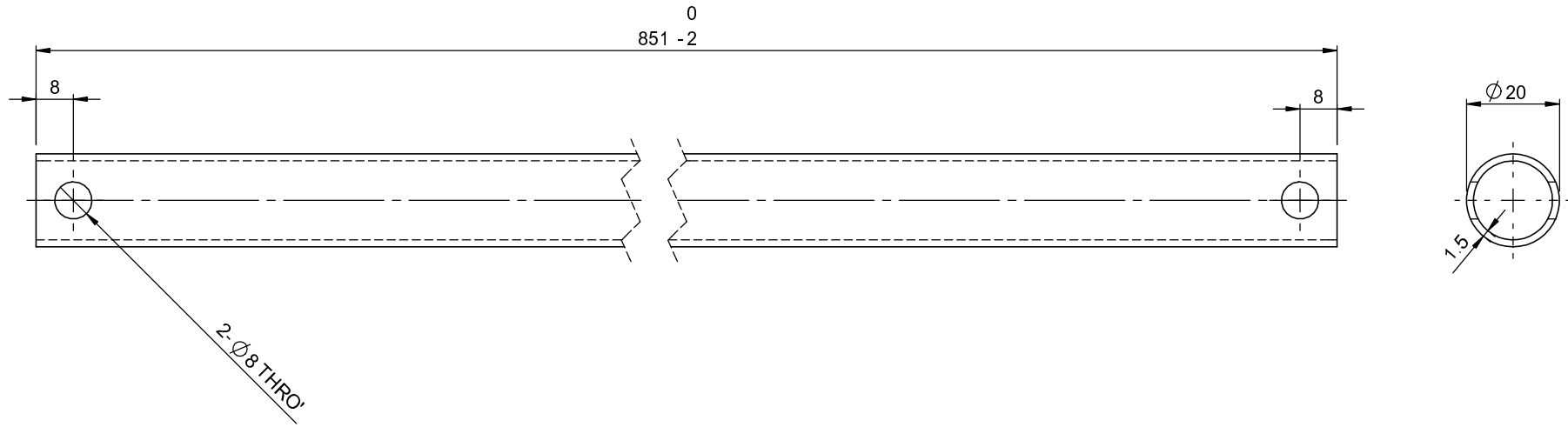

0	29/3/12	ISSUED FOR MANUFACTURE	GC		
P2	6/12/11	ISSUED FOR APPROVAL	GC		
REV	DATE	DESCRIPTION	DRN	CHKD	APPR

TITLE: **BARRIER VERTICAL TUBE**

UNLESS STATED OTHERWISE		
GENERAL TOLERANCES:		
FABRICATION	UP TO 1000mm	+/- 2mm
	1001mm & ABOVE	+/- 3mm
ANGULAR	+/- 0.5 DEGREE	
WEIGHT	+/- 10% (DUE TO MATERIAL PROPERTIES & TOLERANCES)	

NAME	SIGNATURE	DATE
G. CRICK		18/11/11
CHK'D		
FINISH: NONE		

MATERIAL: CARBON STEEL



Dwg/Stock No.	Revision
ZND501-2-5	0

THE COMPANY RETAIN THE RIGHT TO PERIODICALLY ALTER INFORMATION WITHIN THIS DRAWING SHEET AND WILL ATTEMPT TO NOTIFY ALL PARTIES CONCERNED OF ANY CHANGES AND THE INFORMATION ON THIS SHEET SHOULD NOT BE REPRODUCED WITHOUT THEIR WRITTEN CONSENT.

ALL DIMENSIONS IN MILLIMETRES  
REMOVE ALL SHARP EDGES

THIRD ANGLE PROJECTION  
DO NOT SCALE DRAWING

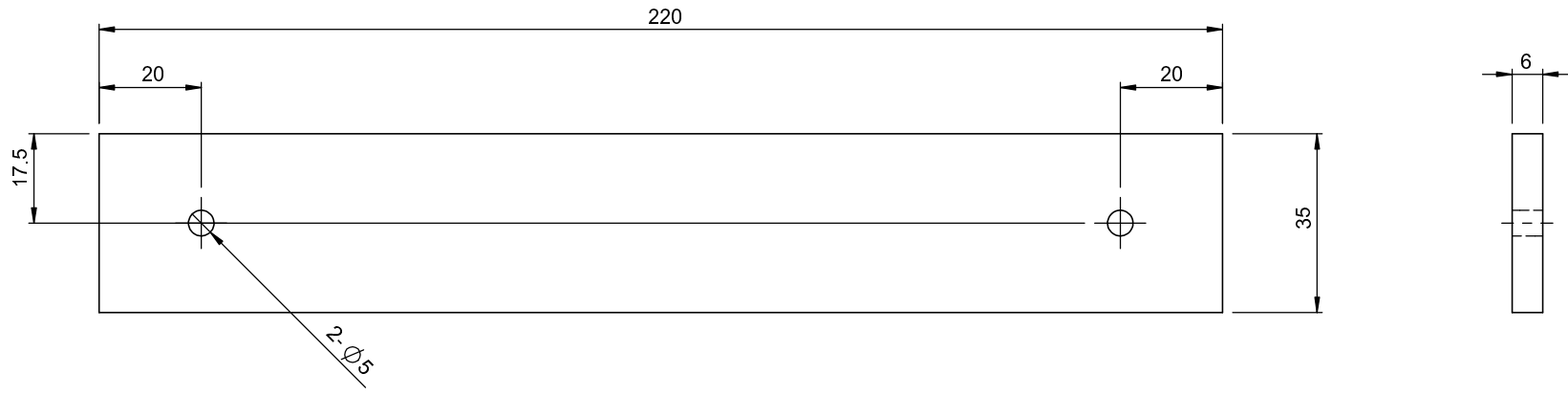

0	29/3/12	ISSUED FOR MANUFACTURE	GC	.	.
P2	6/12/11	ISSUED FOR APPROVAL	GC	.	.
REV	DATE	DESCRIPTION	DRN	CHKD	APPR

TITLE: **BARRIER SIGN PLATE**

UNLESS STATED OTHERWISE		
GENERAL TOLERANCES:		
FABRICATION	UP TO 1000mm	+/- 2mm
	1001mm & ABOVE	+/- 3mm
ANGULAR	+/- 0.5 DEGREE	
WEIGHT	+/- 10% (DUE TO MATERIAL PROPERTIES & TOLERANCES)	

DRAWN	NAME	SIGNATURE	DATE
CHK'D	G. CRICK		18/11/11
FINISH:			
NONE			

MATERIAL: **CARBON STEEL**



Dwg/Stock No. **ZND501-2-6** Revision **0**

THE COMPANY RETAIN THE RIGHT TO PERIODICALLY ALTER INFORMATION WITHIN THIS DRAWING SHEET AND WILL ATTEMPT TO NOTIFY ALL PARTIES CONCERNED OF ANY CHANGES AND THE INFORMATION ON THIS SHEET SHOULD NOT BE REPRODUCED WITHOUT THEIR WRITTEN CONSENT.



1  
2  
3  
4  
5  
6  
7  
8

ALL DIMENSIONS IN MILLIMETRES  
REMOVE ALL SHARP EDGES

THIRD ANGLE PROJECTION  
DO NOT SCALE DRAWING

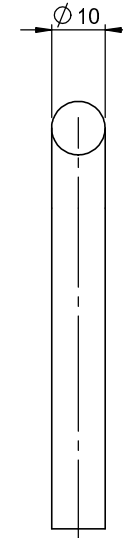
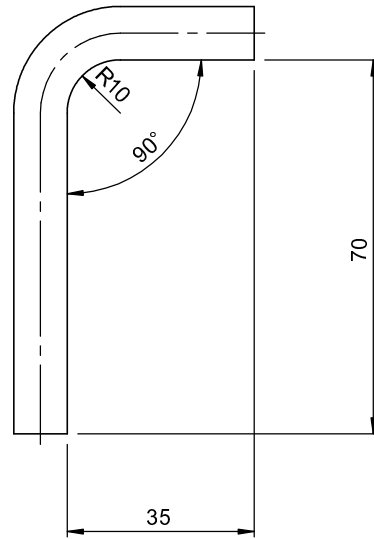

0	29/3/12	ISSUED FOR MANUFACTURE	GC		
P2	6/12/11	ISSUED FOR APPROVAL	GC		
REV	DATE	DESCRIPTION	DRN	CHKD	APPR

TITLE: **BARRIER HOOK**

UNLESS STATED OTHERWISE		
GENERAL TOLERANCES:		
FABRICATION	UP TO 1000mm	+/- 2mm
	1001mm & ABOVE	+/- 3mm
ANGULAR	+/- 0.5 DEGREE	
WEIGHT	+/- 10% (DUE TO MATERIAL PROPERTIES & TOLERANCES)	

	NAME	SIGNATURE	DATE
DRAWN	G. CRICK		18/11/11
CHK'D			
FINISH: NONE			

MATERIAL: CARBON STEEL



Dwg/Stock No.	Revision
<b>ZND501-2-7</b>	<b>0</b>

THE COMPANY RETAIN THE RIGHT TO PERIODICALLY ALTER INFORMATION WITHIN THIS DRAWING SHEET AND WILL ATTEMPT TO NOTIFY ALL PARTIES CONCERNED OF ANY CHANGES AND THE INFORMATION ON THIS SHEET SHOULD NOT BE REPRODUCED WITHOUT THEIR WRITTEN CONSENT.

1  
2  
3  
4  
5  
6  
7  
8

ALL DIMENSIONS IN MILLIMETRES  
REMOVE ALL SHARP EDGES

THIRD ANGLE PROJECTION  
DO NOT SCALE DRAWING

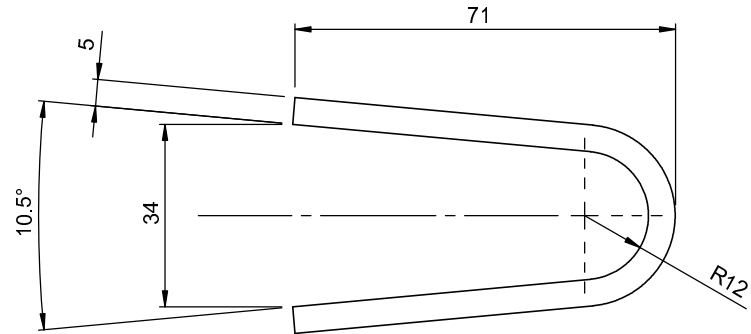

0	29/3/12	ISSUED FOR MANUFACTURE	GC	.	.
P2	6/12/11	ISSUED FOR APPROVAL	GC	.	.
REV	DATE	DESCRIPTION	DRN	CHKD	APPR

TITLE: **BARRIER EYE**

UNLESS STATED OTHERWISE		
GENERAL TOLERANCES:		
FABRICATION	UP TO 1000mm	+/- 2mm
	1001mm & ABOVE	+/- 3mm
ANGULAR	+/- 0.5 DEGREE	
WEIGHT	+/- 10% (DUE TO MATERIAL PROPERTIES & TOLERANCES)	

DRAWN	NAME	SIGNATURE	DATE
CHK'D	G. CRICK		18/11/11
FINISH: NONE			

MATERIAL: CARBON STEEL



Dwg/Stock No.	Revision
ZND501-2-8	0

THE COMPANY RETAIN THE RIGHT TO PERIODICALLY ALTER INFORMATION WITHIN THIS DRAWING SHEET AND WILL ATTEMPT TO NOTIFY ALL PARTIES CONCERNED OF ANY CHANGES AND THE INFORMATION ON THIS SHEET SHOULD NOT BE REPRODUCED WITHOUT THEIR WRITTEN CONSENT.

1  
2  
3  
4  
5  
6  
7  
8

ALL DIMENSIONS IN MILLIMETRES  
REMOVE ALL SHARP EDGES

THIRD ANGLE PROJECTION  
DO NOT SCALE DRAWING

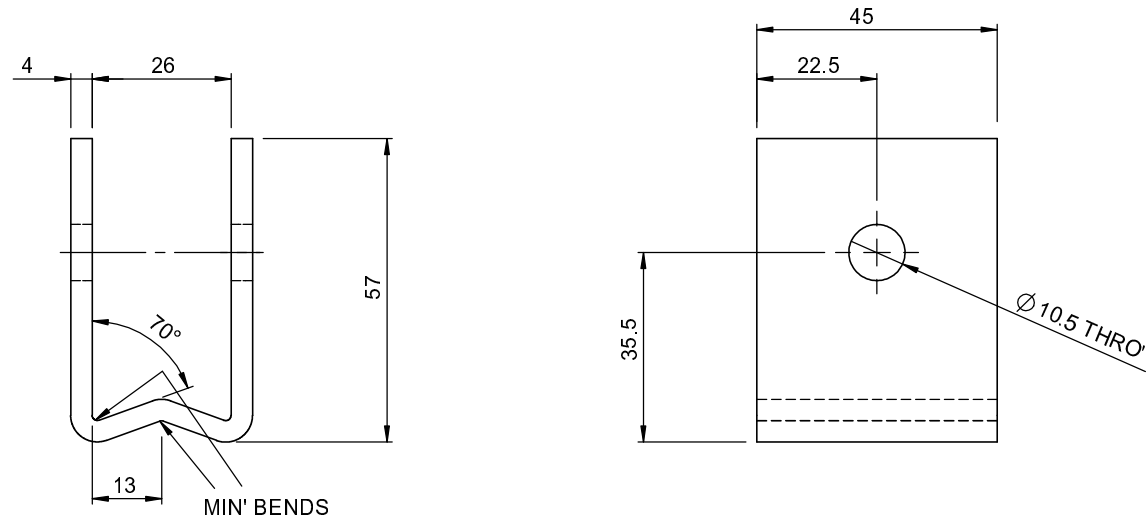

0	29/3/12	ISSUED FOR MANUFACTURE	GC		
P2	6/12/11	ISSUED FOR APPROVAL	GC		
REV	DATE	DESCRIPTION	DRN	CHKD	APPR

TITLE: **BARRIER LEG BRACKET**

UNLESS STATED OTHERWISE		
GENERAL TOLERANCES:		
FABRICATION	UP TO 1000mm	+/- 2mm
	1001mm & ABOVE	+/- 3mm
ANGULAR	+/- 0.5 DEGREE	
WEIGHT	+/- 10% (DUE TO MATERIAL PROPERTIES & TOLERANCES)	

	NAME	SIGNATURE	DATE
DRAWN	G. CRICK		18/11/11
CHK'D			
FINISH: NONE			

MATERIAL: CARBON STEEL



Dwg/Stock No. **ZND501-2-9** Revision **0**

THE COMPANY RETAIN THE RIGHT TO PERIODICALLY ALTER INFORMATION WITHIN THIS DRAWING SHEET AND WILL ATTEMPT TO NOTIFY ALL PARTIES CONCERNED OF ANY CHANGES AND THE INFORMATION ON THIS SHEET SHOULD NOT BE REPRODUCED WITHOUT THEIR WRITTEN CONSENT.

1 2 3 4 5 6 7 8  
 ALL DIMENSIONS IN MILLIMETRES  
 REMOVE ALL SHARP EDGES

THIRD ANGLE PROJECTION  
 DO NOT SCALE DRAWING

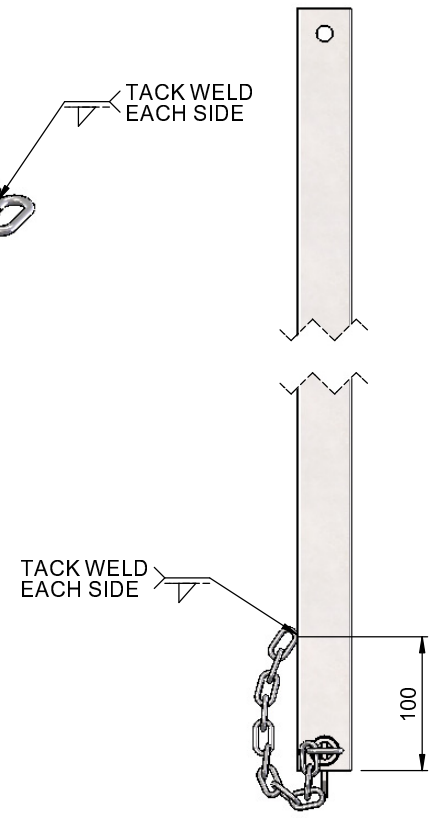
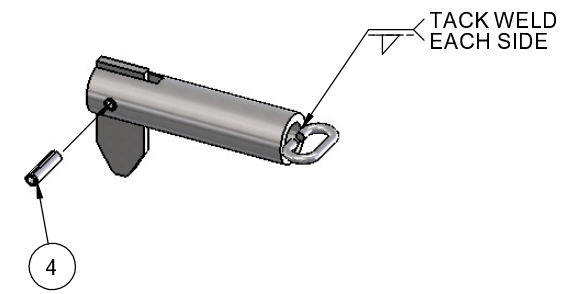
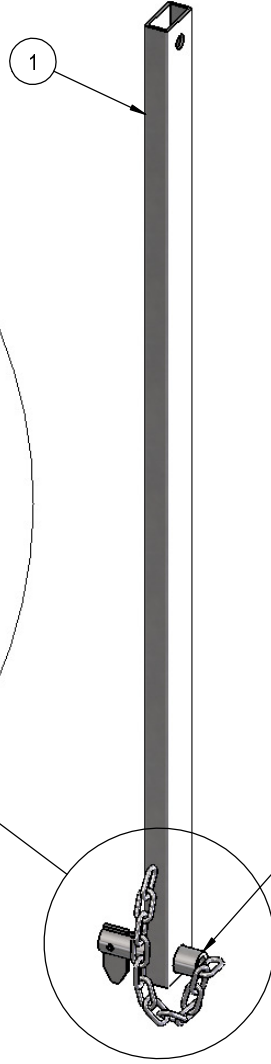
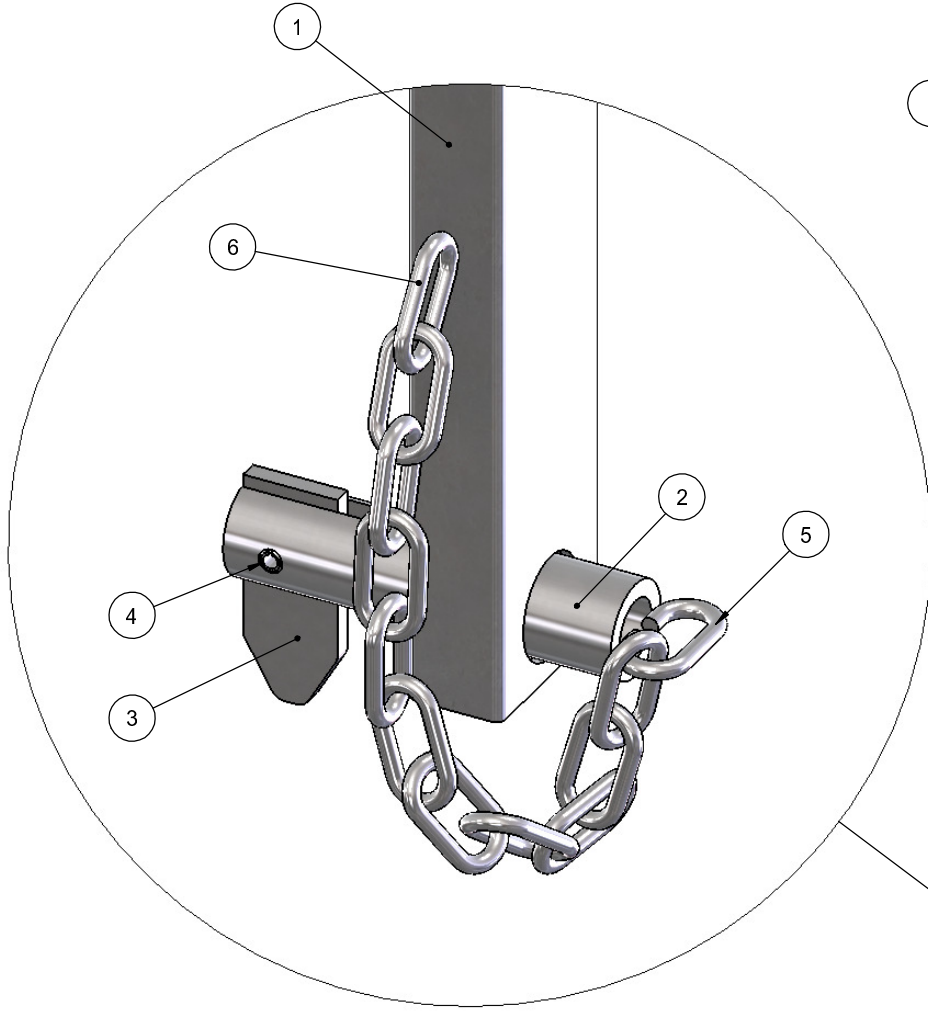

ITEM No.	PART No.	DESCRIPTION	QTY
1	ZND501-3-1	LEG TUBE	1
2	ZND501-3-2	LOCKING PIN	1
3	ZND501-3-3	LOCKING PLATE	1
4		∅5 x 20 Lg ROLL PIN	1
5	ZND501-3-4	CHAIN CONNECTOR	1
6	ZND501-3-5	CHAIN LINK	11

0	29/3/12	ISSUED FOR MANUFACTURE	GC		
P2	6/12/11	ISSUED FOR APPROVAL	GC		
REV	DATE	DESCRIPTION	DRN	CHKD	APPR

TITLE: POLICE BARRIER LEG - FABRICATION SHT 1			
NAME	SIGNATURE	DATE	MATERIAL:
G. CRICK		18/11/11	CARBON STEEL
CHK'D			
FINISH:	NONE		



THE COMPANY RETAIN THE RIGHT TO PERIODICALLY ALTER INFORMATION WITHIN THIS DRAWING SHEET AND WILL ATTEMPT TO NOTIFY ALL PARTIES CONCERNED OF ANY CHANGES AND THE INFORMATION ON THIS SHEET SHOULD NOT BE REPRODUCED WITHOUT THEIR WRITTEN CONSENT.

UNLESS STATED OTHERWISE		
GENERAL TOLERANCES:		
FABRICATION	UP TO 1000mm	+/- 2mm
	1001mm & ABOVE	+/- 3mm
ANGULAR	+/- 0.5 DEGREE	
WEIGHT	+/- 10% (DUE TO MATERIAL PROPERTIES & TOLERANCES)	

ALL DIMENSIONS IN MILLIMETRES  
REMOVE ALL SHARP EDGES

THIRD ANGLE PROJECTION  
DO NOT SCALE DRAWING

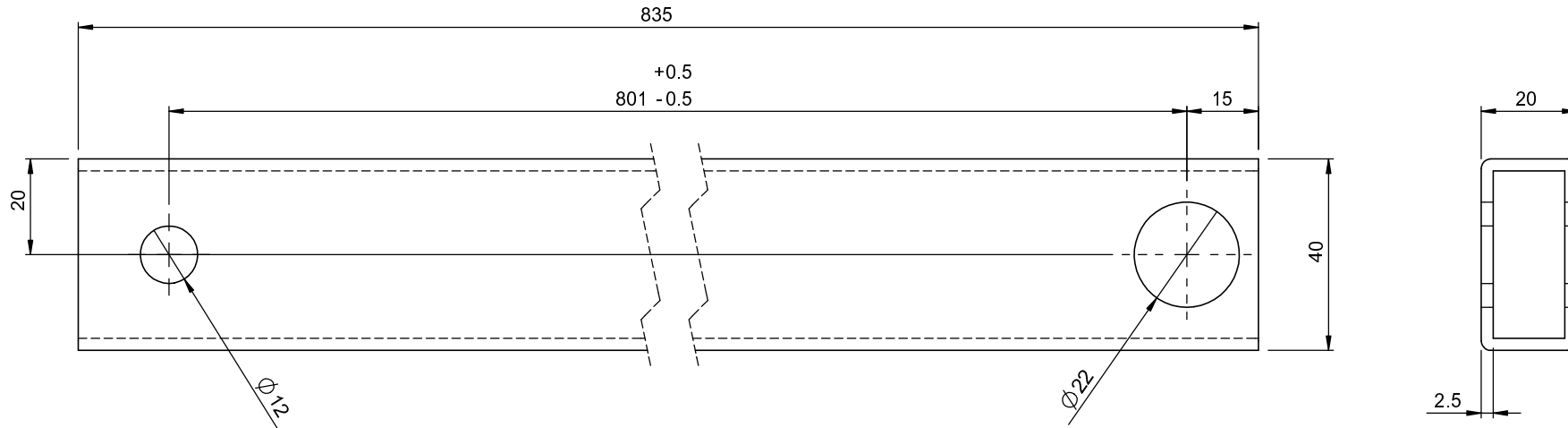

0	29/3/12	ISSUED FOR MANUFACTURE	GC		
P2	6/12/11	ISSUED FOR APPROVAL	GC		
REV	DATE	DESCRIPTION	DRN	CHKD	APPR

TITLE: **LEG TUBE**

UNLESS STATED OTHERWISE		
GENERAL TOLERANCES:		
FABRICATION	UP TO 1000mm	+/- 2mm
	1001mm & ABOVE	+/- 3mm
ANGULAR	+/- 0.5 DEGREE	
WEIGHT	+/- 10% (DUE TO MATERIAL PROPERTIES & TOLERANCES)	

DRAWN	NAME	SIGNATURE	DATE
CHK'D	G. CRICK		19/11/11
FINISH:			
NONE			

MATERIAL:  
**CARBON STEEL**



Dwg/Stock No. **ZND501-3-1** Revision **0**

THE COMPANY RETAIN THE RIGHT TO PERIODICALLY ALTER INFORMATION WITHIN THIS DRAWING SHEET AND WILL ATTEMPT TO NOTIFY ALL PARTIES CONCERNED OF ANY CHANGES AND THE INFORMATION ON THIS SHEET SHOULD NOT BE REPRODUCED WITHOUT THEIR WRITTEN CONSENT.

1  
2  
3  
4  
5  
6  
7  
8

ALL DIMENSIONS IN MILLIMETRES  
REMOVE ALL SHARP EDGES

THIRD ANGLE PROJECTION  
DO NOT SCALE DRAWING

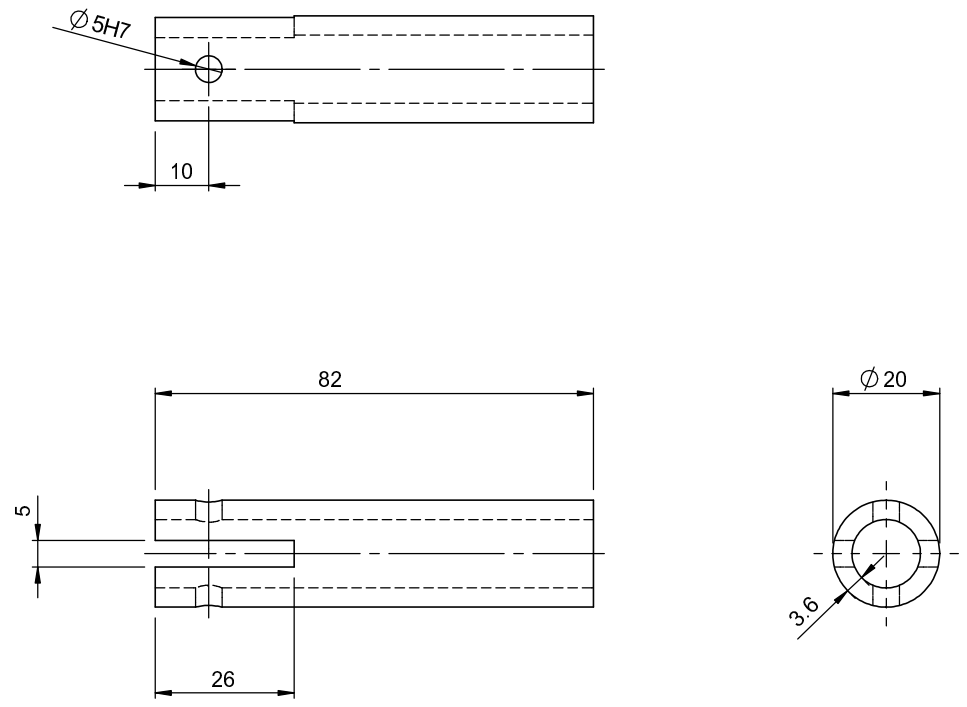

0	29/3/12	ISSUED FOR MANUFACTURE	GC		
P2	6/12/11	ISSUED FOR APPROVAL	GC		
REV	DATE	DESCRIPTION	DRN	CHKD	APPR

TITLE: **BARRIER LEG LOCKING PIN**

UNLESS STATED OTHERWISE		
GENERAL TOLERANCES:		
FABRICATION	UP TO 1000mm	+/- 2mm
	1001mm & ABOVE	+/- 3mm
ANGULAR	+/- 0.5 DEGREE	
WEIGHT	+/- 10% (DUE TO MATERIAL PROPERTIES & TOLERANCES)	

DRAWN	NAME	SIGNATURE	DATE
CHK'D	G. CRICK		19/11/11
FINISH:	NONE		

MATERIAL: CARBON STEEL



Dwg/Stock No. **ZND501-3-2** Revision **0**

THE COMPANY RETAIN THE RIGHT TO PERIODICALLY ALTER INFORMATION WITHIN THIS DRAWING SHEET AND WILL ATTEMPT TO NOTIFY ALL PARTIES CONCERNED OF ANY CHANGES AND THE INFORMATION ON THIS SHEET SHOULD NOT BE REPRODUCED WITHOUT THEIR WRITTEN CONSENT.

1  
2  
3  
4  
5  
6  
7  
8

ALL DIMENSIONS IN MILLIMETRES  
REMOVE ALL SHARP EDGES

THIRD ANGLE PROJECTION  
DO NOT SCALE DRAWING

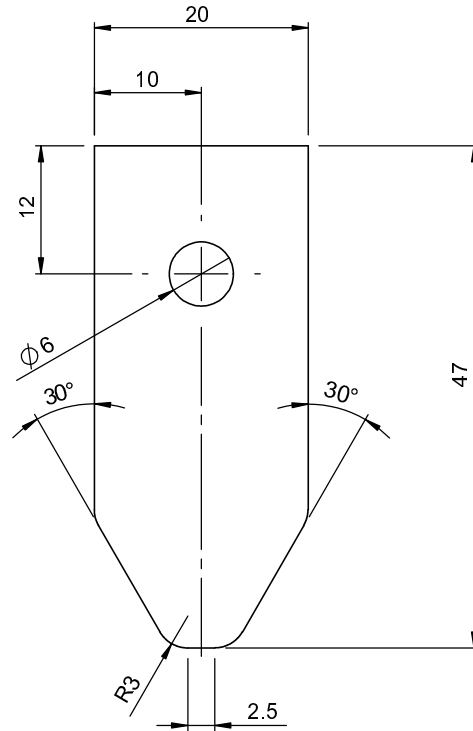

0	29/3/12	ISSUED FOR MANUFACTURE	GC		
P2	6/12/11	ISSUED FOR APPROVAL	GC		
REV	DATE	DESCRIPTION	DRN	CHKD	APPR

TITLE: **BARRIER LEG LOCKING PLATE**

UNLESS STATED OTHERWISE		
GENERAL TOLERANCES:		
FABRICATION	UP TO 1000mm	+/- 2mm
	1001mm & ABOVE	+/- 3mm
ANGULAR	+/- 0.5 DEGREE	
WEIGHT	+/- 10% (DUE TO MATERIAL PROPERTIES & TOLERANCES)	

NAME	SIGNATURE	DATE
G. CRICK		19/11/11
CHK'D		
FINISH: NONE		

MATERIAL: CARBON STEEL



Dwg/Stock No.	Revision
<b>ZND501-3-3</b>	<b>0</b>

THE COMPANY RETAIN THE RIGHT TO PERIODICALLY ALTER INFORMATION WITHIN THIS DRAWING SHEET AND WILL ATTEMPT TO NOTIFY ALL PARTIES CONCERNED OF ANY CHANGES AND THE INFORMATION ON THIS SHEET SHOULD NOT BE REPRODUCED WITHOUT THEIR WRITTEN CONSENT.

1  
2  
3  
4  
5  
6  
7  
8

ALL DIMENSIONS IN MILLIMETRES  
REMOVE ALL SHARP EDGES

THIRD ANGLE PROJECTION  
DO NOT SCALE DRAWING

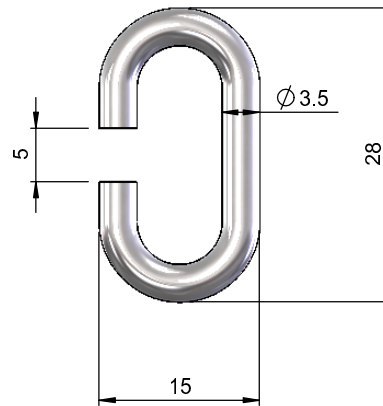

0	29/3/12	ISSUED FOR MANUFACTURE	GC	.	.
P2	6/12/11	ISSUED FOR APPROVAL	GC	.	.
REV	DATE	DESCRIPTION	DRN	CHKD	APPR

TITLE: **BARRIER LEG  
CHAIN CONNECTOR**

UNLESS STATED OTHERWISE		
GENERAL TOLERANCES:		
FABRICATION	UP TO 1000mm	+/- 2mm
	1001mm & ABOVE	+/- 3mm
ANGULAR	+/- 0.5 DEGREE	
WEIGHT	+/- 10% (DUE TO MATERIAL PROPERTIES & TOLERANCES)	

NAME	SIGNATURE	DATE
G. CRICK		19/11/11
CHK'D		
FINISH:		
NONE		

MATERIAL:  
**CARBON STEEL**



Dwg/Stock No. **ZND501-3-4** Revision **0**

THE COMPANY RETAIN THE RIGHT TO PERIODICALLY ALTER INFORMATION WITHIN THIS DRAWING SHEET AND WILL ATTEMPT TO NOTIFY ALL PARTIES CONCERNED OF ANY CHANGES AND THE INFORMATION ON THIS SHEET SHOULD NOT BE REPRODUCED WITHOUT THEIR WRITTEN CONSENT.



1  
2  
3  
4  
5  
6  
7  
8

ALL DIMENSIONS IN MILLIMETRES  
REMOVE ALL SHARP EDGES

THIRD ANGLE PROJECTION  
DO NOT SCALE DRAWING

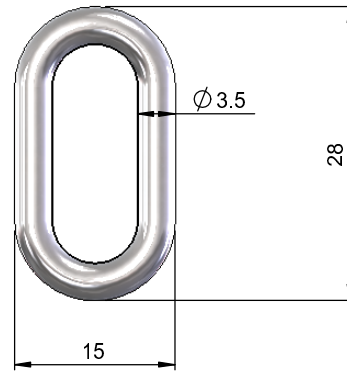

TYPICAL CHAIN LINK DETAILS

0	29/3/12	ISSUED FOR MANUFACTURE	GC	.	.
P2	6/12/11	ISSUED FOR APPROVAL	GC	.	.
REV	DATE	DESCRIPTION	DRN	CHKD	APPR

TITLE: <b>BARRIER LEG CHAIN LINK</b>				MATERIAL: <b>CARBON STEEL</b>	
NAME	SIGNATURE	DATE	DRAWN G. CRICK 19/11/11	CHK'D .	FINISH: <b>NONE</b>
WEIGHT:					



Dwg/Stock No. <b>ZND501-3-5</b>	Revision <b>0</b>
------------------------------------	----------------------

UNLESS STATED OTHERWISE		
GENERAL TOLERANCES:		
FABRICATION	UP TO 1000mm	+/- 2mm
	1001mm & ABOVE	+/- 3mm
ANGULAR	+/- 0.5 DEGREE	
WEIGHT	+/- 10% (DUE TO MATERIAL PROPERTIES & TOLERANCES)	

THE COMPANY RETAIN THE RIGHT TO PERIODICALLY ALTER INFORMATION WITHIN THIS DRAWING SHEET AND WILL ATTEMPT TO NOTIFY ALL PARTIES CONCERNED OF ANY CHANGES AND THE INFORMATION ON THIS SHEET SHOULD NOT BE REPRODUCED WITHOUT THEIR WRITTEN CONSENT.

1  
2  
3  
4  
5  
6  
7  
8

ALL DIMENSIONS IN MILLIMETRES  
REMOVE ALL SHARP EDGES

THIRD ANGLE PROJECTION  
DO NOT SCALE DRAWING

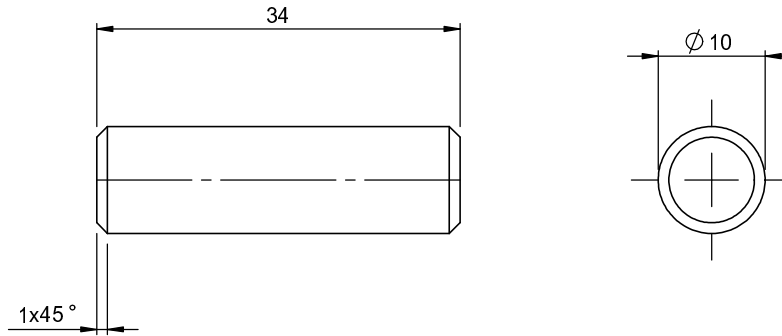

0	29/3/12	ISSUED FOR MANUFACTURE	GC	.	.
P2	6/12/11	ISSUED FOR APPROVAL	GC	.	.
REV	DATE	DESCRIPTION	DRN	CHKD	APPR

TITLE: **BARRIER LEG HINGE PIN**

UNLESS STATED OTHERWISE		
GENERAL TOLERANCES:		
FABRICATION	UP TO 1000mm	+/- 2mm
	1001mm & ABOVE	+/- 3mm
ANGULAR	+/- 0.5 DEGREE	
WEIGHT	+/- 10% (DUE TO MATERIAL PROPERTIES & TOLERANCES)	

NAME	SIGNATURE	DATE
G. CRICK		19/11/11
CHK'D		
FINISH:		
NONE		

MATERIAL:  
**CARBON STEEL**



Dwg/Stock No.	Revision
<b>ZND501-4</b>	<b>0</b>

THE COMPANY RETAIN THE RIGHT TO PERIODICALLY ALTER INFORMATION WITHIN THIS DRAWING SHEET AND WILL ATTEMPT TO NOTIFY ALL PARTIES CONCERNED OF ANY CHANGES AND THE INFORMATION ON THIS SHEET SHOULD NOT BE REPRODUCED WITHOUT THEIR WRITTEN CONSENT.