

1
2
3
4
5
6
7
8

ALL DIMENSIONS IN MILLIMETRES
REMOVE ALL SHARP EDGES

THIRD ANGLE PROJECTION
DO NOT SCALE DRAWING

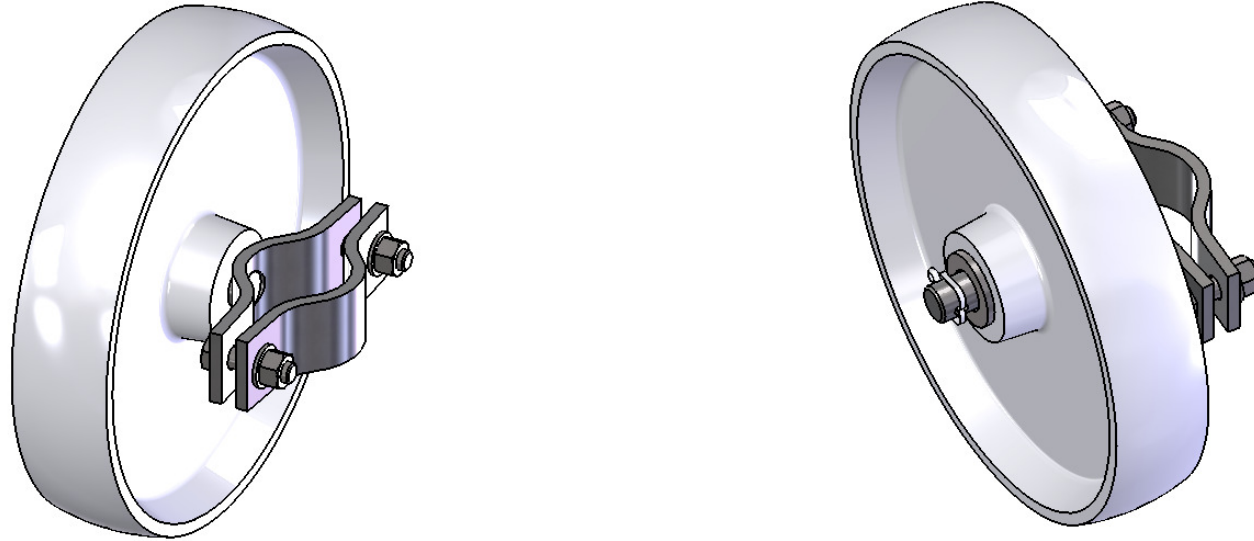

1	28/3/12	ISSUED FOR MANUFACTURE	GC	.	.
0	19/12/11	ISSUED FOR MANUFACTURE	GC	.	.
REV	DATE	DESCRIPTION	DRN	CHKD	APPR

TITLE: **WHEEL**

UNLESS STATED OTHERWISE		
GENERAL TOLERANCES:		
FABRICATION	UP TO 1000mm	+/- 2mm
	1001mm & ABOVE	+/- 3mm
ANGULAR	+/- 0.5 DEGREE	
WEIGHT	+/- 10% (DUE TO MATERIAL PROPERTIES & TOLERANCES)	

DRAWN	NAME	SIGNATURE	DATE
CHK'D	G. CRICK		19/12/11
FINISH:	HOTDIPPED GALVANISED		

MATERIAL: **CARBON STEEL**



CODE No. 1046

Dwg/Stock No.	Revision
ZND518	1

THE COMPANY RETAIN THE RIGHT TO PERIODICALLY ALTER INFORMATION WITHIN THIS DRAWING SHEET AND WILL ATTEMPT TO NOTIFY ALL PARTIES CONCERNED OF ANY CHANGES AND THE INFORMATION ON THIS SHEET SHOULD NOT BE REPRODUCED WITHOUT THEIR WRITTEN CONSENT.

1 2 3 4 5 6 7 8
 ALL DIMENSIONS IN MILLIMETRES
 REMOVE ALL SHARP EDGES

THIRD ANGLE PROJECTION
 DO NOT SCALE DRAWING

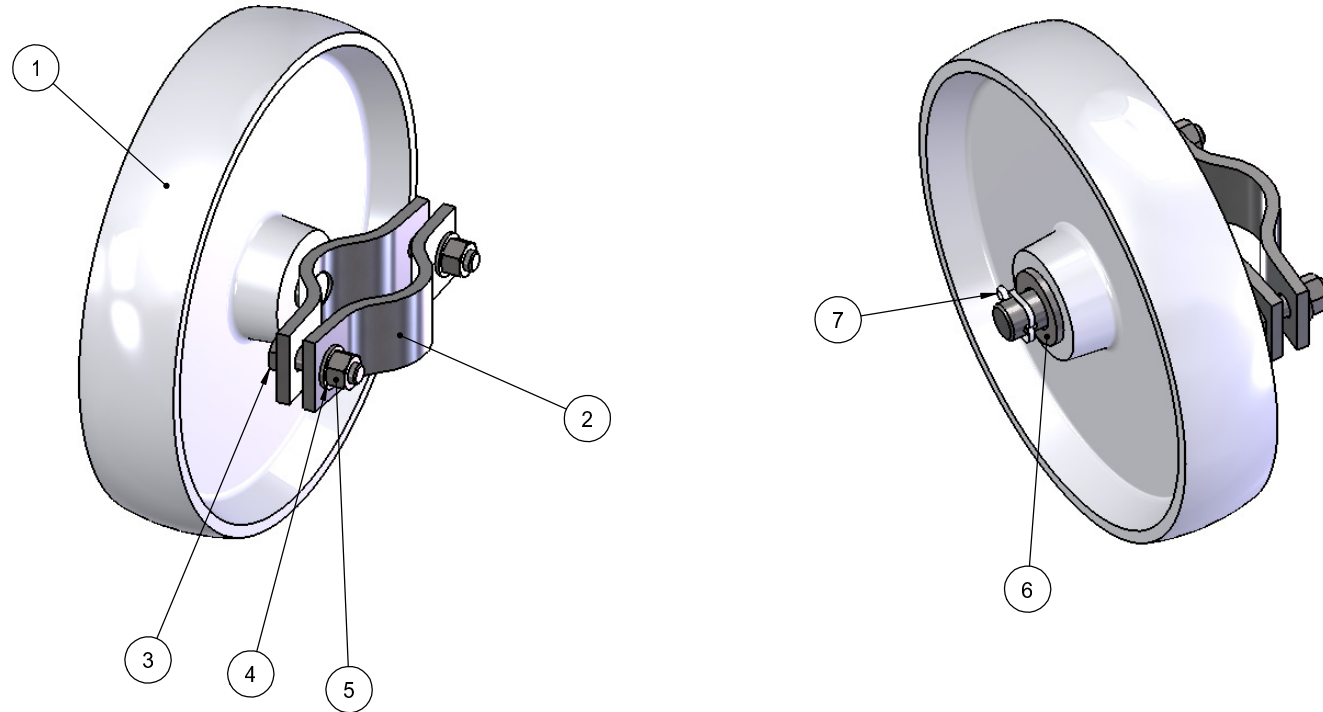

ITEM No.	PART No.	DESCRIPTION	QTY
1	ZND518-1	WHEEL	1
2	ZND518-2	CLAMP	1
3		M8 x 30 Lg HEX HEAD SET SCREW - GALV	2
4		M8 PLAIN WASHER - GALV	2
5		M8 LOCK NUT - GALV	2
6		M16 PLAIN WASHER - GALV	1
7		M5 x 36 SPLIT PIN - GALV	1

REV	DATE	DESCRIPTION	DRN	CHKD	APPR
1	28/3/12	ISSUED FOR MANUFACTURE	GC		
0	19/12/11	ISSUED FOR MANUFACTURE	GC		

TITLE: WHEEL ASSEMBLY			
DRAWN	NAME	SIGNATURE	DATE
CHK'D	G. CRICK		19/12/11
FINISH:	MATERIAL:		
HOTDIPPED GALVANISED	CARBON STEEL		



CODE No. 1046

THE COMPANY RETAIN THE RIGHT TO PERIODICALLY ALTER INFORMATION WITHIN THIS DRAWING SHEET AND WILL ATTEMPT TO NOTIFY ALL PARTIES CONCERNED OF ANY CHANGES AND THE INFORMATION ON THIS SHEET SHOULD NOT BE REPRODUCED WITHOUT THEIR WRITTEN CONSENT.

UNLESS STATED OTHERWISE		
GENERAL TOLERANCES:		
FABRICATION	UP TO 1000mm	+/- 2mm
	1001mm & ABOVE	+/- 3mm
ANGULAR	+/- 0.5 DEGREE	
WEIGHT	+/- 10% (DUE TO MATERIAL PROPERTIES & TOLERANCES)	

Dwg/Stock No.	Revision
ZND518 - GA	1

ALL DIMENSIONS IN MILLIMETRES
REMOVE ALL SHARP EDGES

THIRD ANGLE PROJECTION
DO NOT SCALE DRAWING

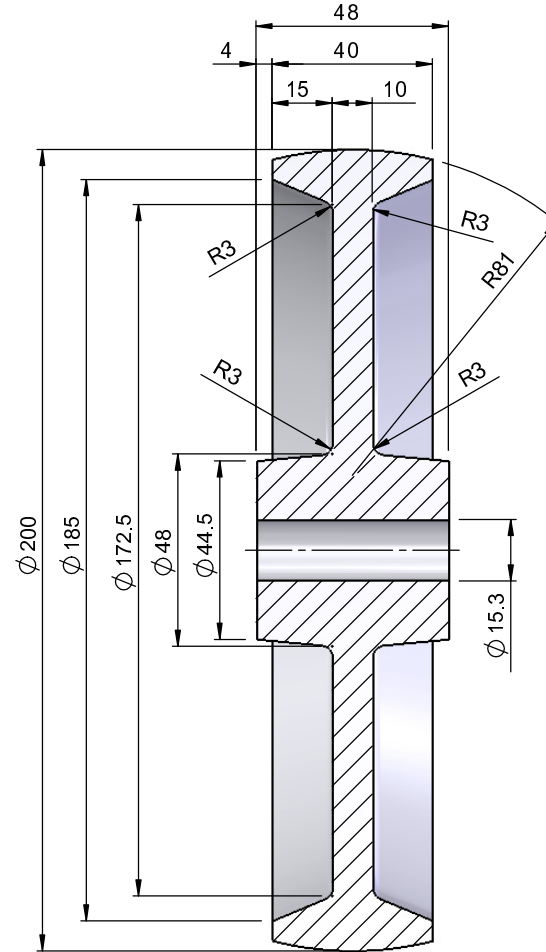
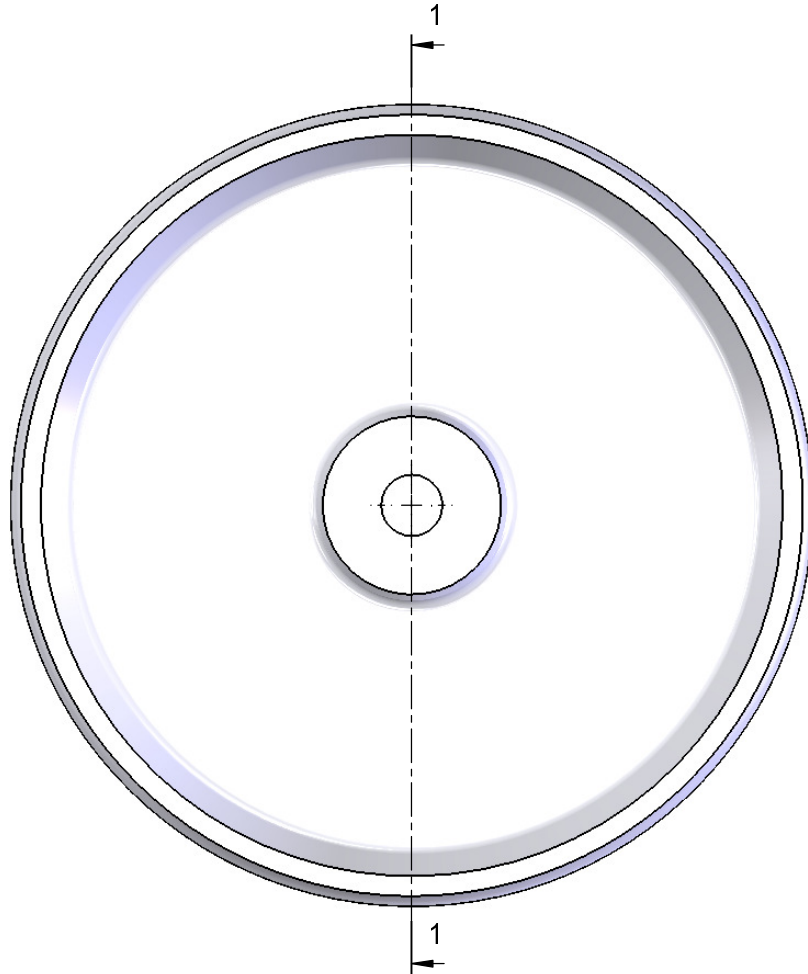

SECTION 1-1

1	28/3/12	ISSUED FOR MANUFACTURE	GC		
0	19/12/11	ISSUED FOR MANUFACTURE	GC		
REV	DATE	DESCRIPTION	DRN	CHKD	APPR

TITLE: **WHEEL**

UNLESS STATED OTHERWISE		
GENERAL TOLERANCES:		
FABRICATION	UP TO 1000mm	+/- 2mm
	1001mm & ABOVE	+/- 3mm
ANGULAR	+/- 0.5 DEGREE	
WEIGHT	+/- 10% (DUE TO MATERIAL PROPERTIES & TOLERANCES)	

DRAWN	NAME	SIGNATURE	DATE
CHK'D	G. CRICK		19/12/11
FINISH:	NONE		

MATERIAL:
DELIRIN



Dwg/Stock No.	Revision
ZND518-1	1

THE COMPANY RETAIN THE RIGHT TO PERIODICALLY ALTER INFORMATION WITHIN THIS DRAWING SHEET AND WILL ATTEMPT TO NOTIFY ALL PARTIES CONCERNED OF ANY CHANGES AND THE INFORMATION ON THIS SHEET SHOULD NOT BE REPRODUCED WITHOUT THEIR WRITTEN CONSENT.

1 ALL DIMENSIONS IN MILLIMETRES
REMOVE ALL SHARP EDGES

8 THIRD ANGLE PROJECTION
DO NOT SCALE DRAWING

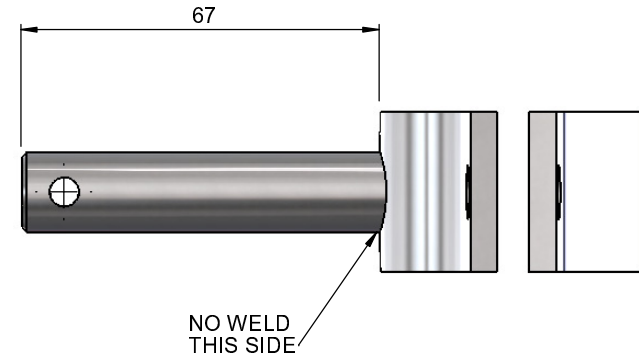
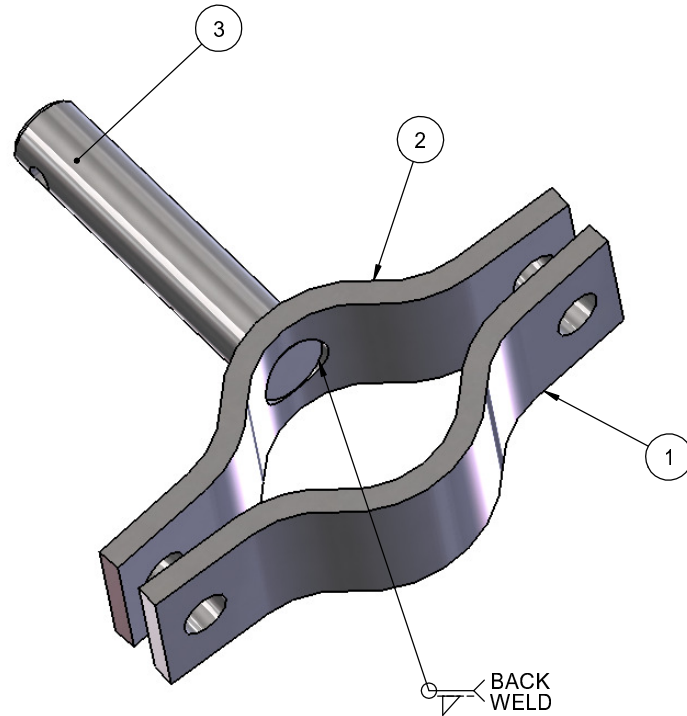

NOTE:
EACH PART TO BE
GALVANISED SEPARATELY

ITEM No.	PART No.	DESCRIPTION	QTY
1	ZND518-2-1	CLAMP BODY LOOSE	1
2	ZND518-2-2	CLAMP BODY FIXED	1
3	ZND518-2-3	PIN	1

WEIGHT NOTE:
WEIGHT BEFORE GALVANISING = 310g
WEIGHT GALVANISED = 329g (ASSUMING 6% ADDED)

REV	DATE	DESCRIPTION	DRN	CHKD	APPR
1	28/3/12	ISSUED FOR MANUFACTURE	GC		
0	19/12/11	ISSUED FOR MANUFACTURE	GC		

TITLE: **CLAMP FABRICATION**

UNLESS STATED OTHERWISE		
GENERAL TOLERANCES:		
FABRICATION	UP TO 1000mm	+/- 2mm
	1001mm & ABOVE	+/- 3mm
ANGULAR	+/- 0.5 DEGREE	
WEIGHT	+/- 10% (DUE TO MATERIAL PROPERTIES & TOLERANCES)	

NAME	SIGNATURE	DATE
DRAWN G. CRICK		19/12/11
CHK'D		
FINISH: HOT DIPPED GALVANISED		

MATERIAL: **CARBON STEEL**



Dwg/Stock No. **ZND518-2 - FAB** Revision **1**

THE COMPANY RETAIN THE RIGHT TO PERIODICALLY ALTER INFORMATION WITHIN THIS DRAWING SHEET AND WILL ATTEMPT TO NOTIFY ALL PARTIES CONCERNED OF ANY CHANGES AND THE INFORMATION ON THIS SHEET SHOULD NOT BE REPRODUCED WITHOUT THEIR WRITTEN CONSENT.

ALL DIMENSIONS IN MILLIMETRES
REMOVE ALL SHARP EDGES

THIRD ANGLE PROJECTION
DO NOT SCALE DRAWING

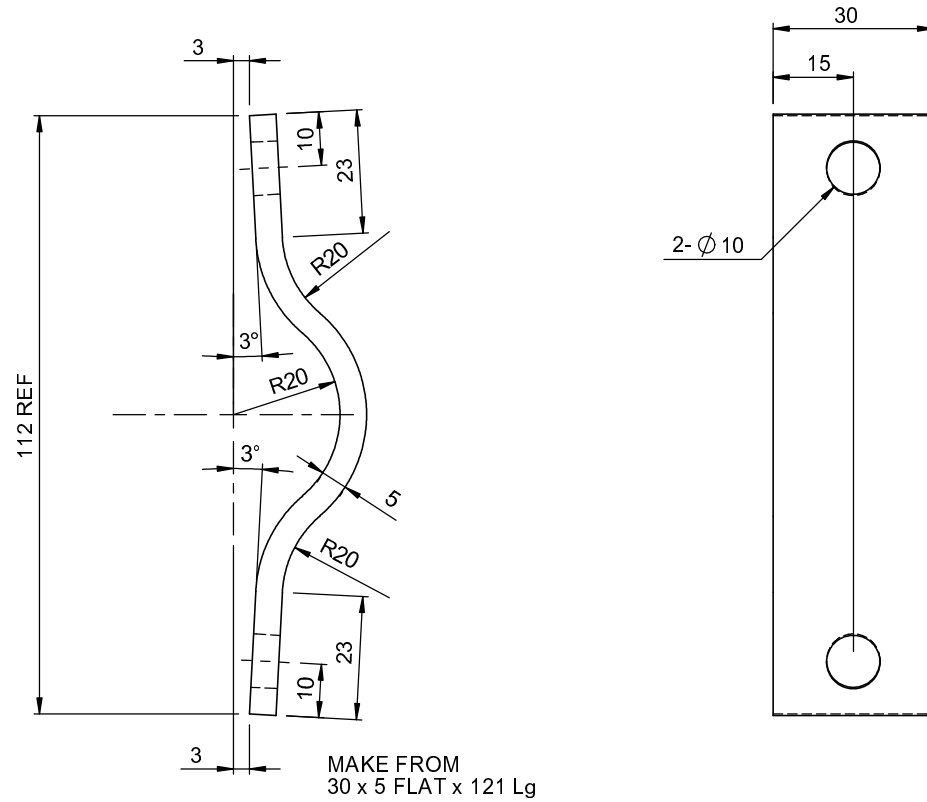

1	28/3/12	ISSUED FOR MANUFACTURE	GC		
0	19/12/11	ISSUED FOR MANUFACTURE	GC		
REV	DATE	DESCRIPTION	DRN	CHKD	APPR

TITLE: CLAMP BODY LOOSE				MATERIAL: CARBON STEEL	
DRAWN	NAME	SIGNATURE	DATE		
CHK'D	G. CRICK		19/12/11		
FINISH:	NONE				
UNLESS STATED OTHERWISE					
GENERAL TOLERANCES:					
FABRICATION	UP TO 1000mm	+/- 2mm			
	1001mm & ABOVE	+/- 3mm			
ANGULAR	+/- 0.5 DEGREE				
WEIGHT	+/- 10% (DUE TO MATERIAL PROPERTIES & TOLERANCES)				

ZNDDE

Dwg/Stock No. **ZND518-2-1** Revision **1**

THE COMPANY RETAIN THE RIGHT TO PERIODICALLY ALTER INFORMATION WITHIN THIS DRAWING SHEET AND WILL ATTEMPT TO NOTIFY ALL PARTIES CONCERNED OF ANY CHANGES AND THE INFORMATION ON THIS SHEET SHOULD NOT BE REPRODUCED WITHOUT THEIR WRITTEN CONSENT.

1
2
3
4
5
6
7
8

ALL DIMENSIONS IN MILLIMETRES
REMOVE ALL SHARP EDGES

THIRD ANGLE PROJECTION
DO NOT SCALE DRAWING

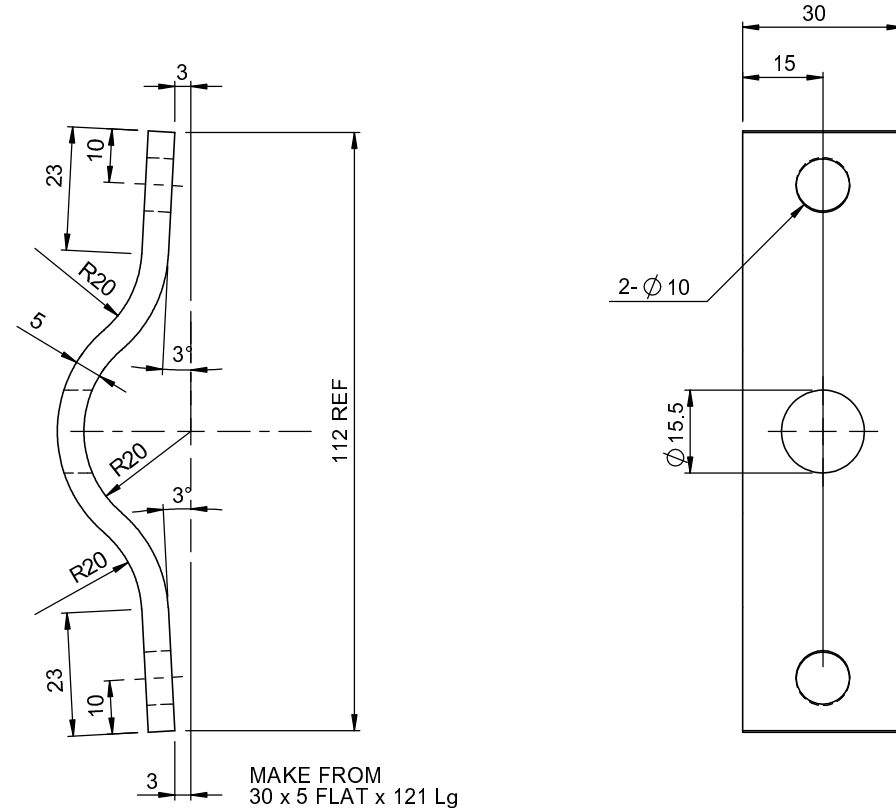

MAKE FROM
30 x 5 FLAT x 121 Lg

1	28/3/12	ISSUED FOR MANUFACTURE	GC		
0	19/12/11	ISSUED FOR MANUFACTURE	GC		
REV	DATE	DESCRIPTION	DRN	CHKD	APPR

TITLE: CLAMP BODY FIXED				MATERIAL: CARBON STEEL	
DRAWN	NAME	SIGNATURE	DATE	NONE	
CHK'D	G. CRICK		19/12/11		
FINISH:					
UNLESS STATED OTHERWISE				WEIGHT:	
GENERAL TOLERANCES:				SCALE: 1:1	
FABRICATION	UP TO 1000mm	+/- 2mm		SHEET 6 OF 7	
	1001mm & ABOVE	+/- 3mm		A3	
ANGULAR	+/- 0.5 DEGREE				
WEIGHT	+/- 10% (DUE TO MATERIAL PROPERTIES & TOLERANCES)				

ZNDDE

Dwg/Stock No. **ZND518-2-2** Revision **1**

THE COMPANY RETAIN THE RIGHT TO PERIODICALLY ALTER INFORMATION WITHIN THIS DRAWING SHEET AND WILL ATTEMPT TO NOTIFY ALL PARTIES CONCERNED OF ANY CHANGES AND THE INFORMATION ON THIS SHEET SHOULD NOT BE REPRODUCED WITHOUT THEIR WRITTEN CONSENT.

1
2
3
4
5
6
7
8

ALL DIMENSIONS IN MILLIMETRES
REMOVE ALL SHARP EDGES

THIRD ANGLE PROJECTION
DO NOT SCALE DRAWING

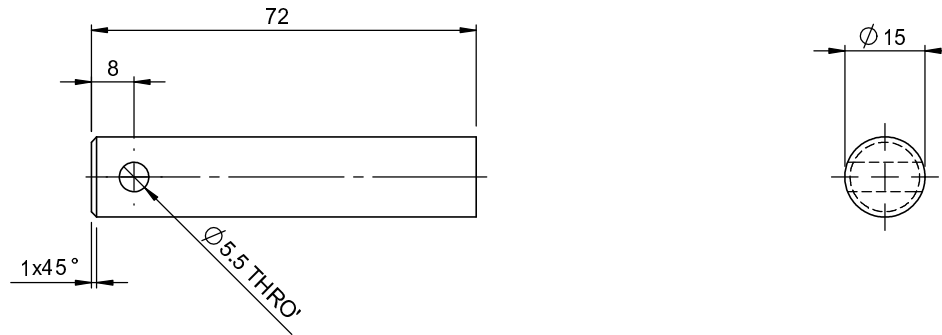

1	28/3/12	ISSUED FOR MANUFACTURE	GC	.	.
0	19/12/11	ISSUED FOR MANUFACTURE	GC	.	.
REV	DATE	DESCRIPTION	DRN	CHKD	APPR

TITLE: **CLAMP PIN**

UNLESS STATED OTHERWISE		
GENERAL TOLERANCES:		
FABRICATION	UP TO 1000mm	+/- 2mm
	1001mm & ABOVE	+/- 3mm
ANGULAR	+/- 0.5 DEGREE	
WEIGHT	+/- 10% (DUE TO MATERIAL PROPERTIES & TOLERANCES)	

DRAWN	NAME	SIGNATURE	DATE
CHK'D	G. CRICK		19/12/11
FINISH:	NONE		

MATERIAL:
CARBON STEEL



Dwg/Stock No.	Revision
ZND518-2-3	1

THE COMPANY RETAIN THE RIGHT TO PERIODICALLY ALTER INFORMATION WITHIN THIS DRAWING SHEET AND WILL ATTEMPT TO NOTIFY ALL PARTIES CONCERNED OF ANY CHANGES AND THE INFORMATION ON THIS SHEET SHOULD NOT BE REPRODUCED WITHOUT THEIR WRITTEN CONSENT.