

ALL DIMENSIONS IN MILLIMETRES  
REMOVE ALL SHARP EDGES

THIRD ANGLE PROJECTION  
DO NOT SCALE DRAWING

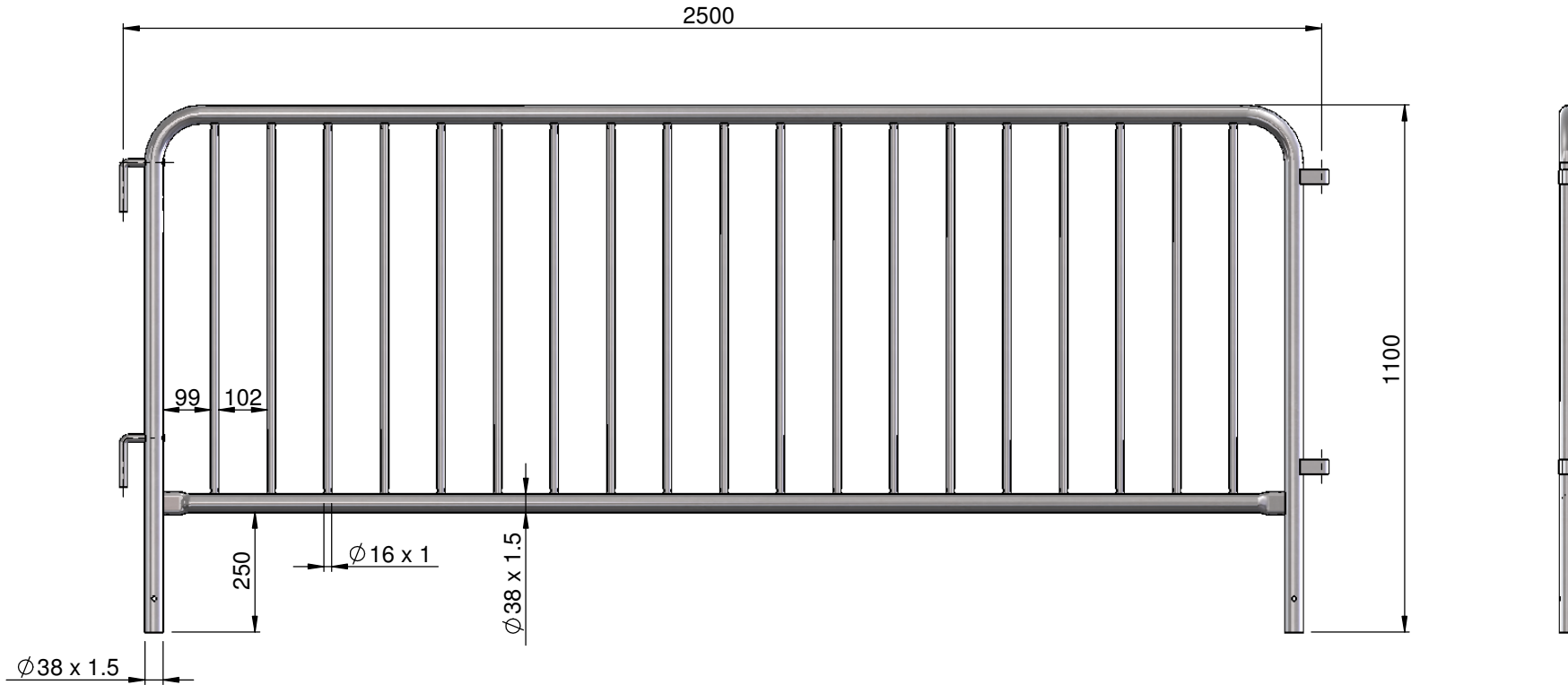

0	31/1/14	ISSUED FOR MANUFACTURE	GC		
REV	DATE	DESCRIPTION	DRN	CHKD	APPR

TOLERANCES - UNLESS STATED OTHERWISE		
UNTOLERANCED DIMENSIONS	+/- 2mm	
CUTTING LENGTHS	+/- 2mm	
FABRICATION	UP TO 300mm	+/- 1mm
	UP TO 1000mm	+/- 2mm
	1001mm & ABOVE	+/- 3mm
	ANGULAR	+/- 1°
MACHINING	+/- 0.2mm	
GAUGE	+/- 10%	
WEIGHT	+/- 10% (DUE TO MATERIAL PROPERTIES & TOLERANCES)	

TITLE: <b>2.5m BAR BARRIER</b>			
NAME	SIGNATURE	DATE	MATERIAL:
DRAWN G. CRICK		31/1/14	CARBON STEEL
CHK'D			
FINISH: <b>HOT DIPPED GALVANISED</b>			

**ZNDUK**<sub>e</sub>

Drw / Stockcode No. **ZND548** Revision **0**

EURO **Mannesmanngitter ohne FuB 2.5m mit Haken und Öse - 1074**

THE COMPANY RETAIN THE RIGHT TO PERIODICALLY ALTER INFORMATION WITHIN THIS DRAWING SHEET AND WILL ATTEMPT TO NOTIFY ALL PARTIES CONCERNED OF ANY CHANGES AND THE INFORMATION ON THIS SHEET SHOULD NOT BE REPRODUCED WITHOUT THEIR WRITTEN CONSENT.

WEIGHT: **16.2 Kg**

SCALE: 1:10

SHEET 1 OF 7

A3

ALL DIMENSIONS IN MILLIMETRES  
REMOVE ALL SHARP EDGES

THIRD ANGLE PROJECTION  
DO NOT SCALE DRAWING

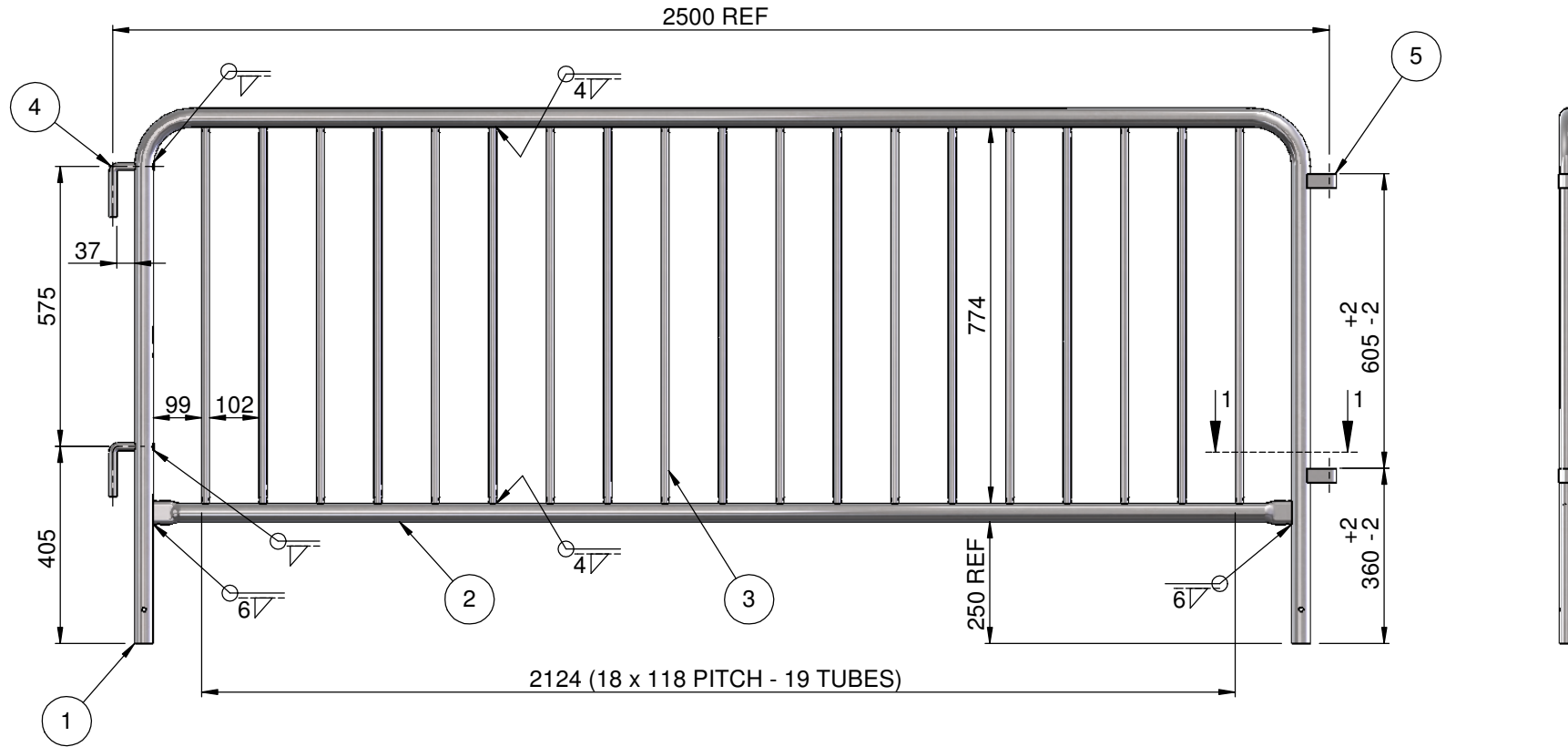
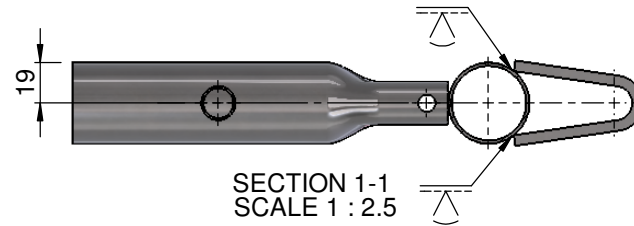

ITEM No.	PART No.	DESCRIPTION	QTY
1	ZND548-1	FRAME TUBE	1
2	ZND548-2	HORIZONTAL TUBE	1
3	ZND548-3	INNFILL TUBE	19
4	ZND548-4	HOOK	2
5	ZND548-5	EYE	2

WEIGHT NOTE:  
WEIGHT BEFORE GALVANISING = 15.3Kg  
WEIGHT GALVANISED = 16.2Kg (ASSUMING 6% ADDED)

REV	DATE	DESCRIPTION	DRN	CHKD	APPR
0	31/1/14	ISSUED FOR MANUFACTURE	GC		

TOLERANCES - UNLESS STATED OTHERWISE		TITLE:	
UNTOLERANCED DIMENSIONS	+/- 2mm	<b>2.5m BAR BARRIER</b>	
CUTTING LENGTHS	+/- 2mm		
FABRICATION	UP TO 300mm	NAME	SIGNATURE
	UP TO 1000mm	DATE	MATERIAL:
	1001mm & ABOVE	31/1/14	CARBON STEEL
ANGULAR	+/- 3mm	DRAWN	
MACHINING	+/- 0.2mm	CHK'D	
GAUGE	+/- 10%	FINISH: HOT DIPPED GALVANISED	
WEIGHT	+/- 10% (DUE TO MATERIAL PROPERTIES & TOLERANCES)	WARRANTY: 10 YEARS	

**ZNDUK**<sub>e</sub>

EURO Mannesmanngitter ohne FuB 2.5m mit Haken und Öse - 1074

THE COMPANY RETAIN THE RIGHT TO PERIODICALLY ALTER INFORMATION WITHIN THIS DRAWING SHEET AND WILL ATTEMPT TO NOTIFY ALL PARTIES CONCERNED OF ANY CHANGES AND THE INFORMATION ON THIS SHEET SHOULD NOT BE REPRODUCED WITHOUT THEIR WRITTEN CONSENT.

Drw / Stockcode No. ZND548 Revision 0

WARRANTY: 10 YEARS

WEIGHT: 16.2 Kg SCALE: 1:10 SHEET 2 OF 7 A3

ALL DIMENSIONS IN MILLIMETRES  
REMOVE ALL SHARP EDGES

THIRD ANGLE PROJECTION  
DO NOT SCALE DRAWING

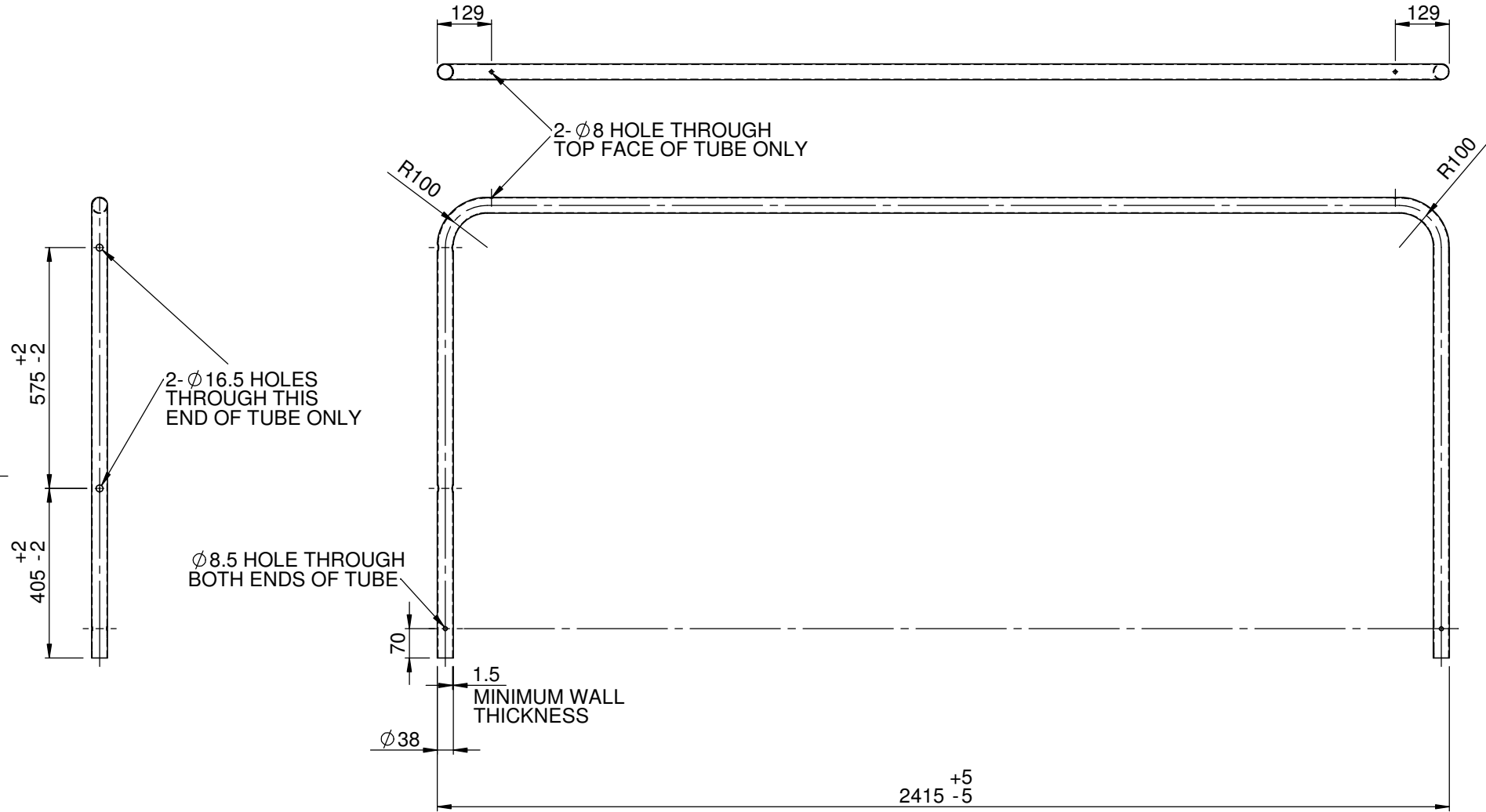

0	31/1/14	ISSUED FOR MANUFACTURE	GC		
REV	DATE	DESCRIPTION	DRN	CHKD	APPR

TOLERANCES - UNLESS STATED OTHERWISE		TITLE:			
UNTOLERANCED DIMENSIONS	+/- 2mm	<b>BARRIER FRAME TUBE</b>			
CUTTING LENGTHS	+/- 2mm				
FABRICATION	UP TO 300mm	+/- 1mm	NAME	SIGNATURE	DATE
	UP TO 1000mm	+/- 2mm	DRAWN	G. CRICK	31/1/14
	1001mm & ABOVE	+/- 3mm	CHK'D		
	ANGULAR	+/- 1°	MATERIAL:		
MACHINING	+/- 0.2mm	FINISH:			CARBON STEEL
GAUGE	+/- 10%	NONE			
WEIGHT	+/- 10% (DUE TO MATERIAL PROPERTIES & TOLERANCES)				



Drw / Stockcode No.	Revision
<b>ZND548-1</b>	<b>0</b>

THE COMPANY RETAIN THE RIGHT TO PERIODICALLY ALTER INFORMATION WITHIN THIS DRAWING SHEET AND WILL ATTEMPT TO NOTIFY ALL PARTIES CONCERNED OF ANY CHANGES AND THE INFORMATION ON THIS SHEET SHOULD NOT BE REPRODUCED WITHOUT THEIR WRITTEN CONSENT.

ALL DIMENSIONS IN MILLIMETRES  
REMOVE ALL SHARP EDGES

THIRD ANGLE PROJECTION  
DO NOT SCALE DRAWING

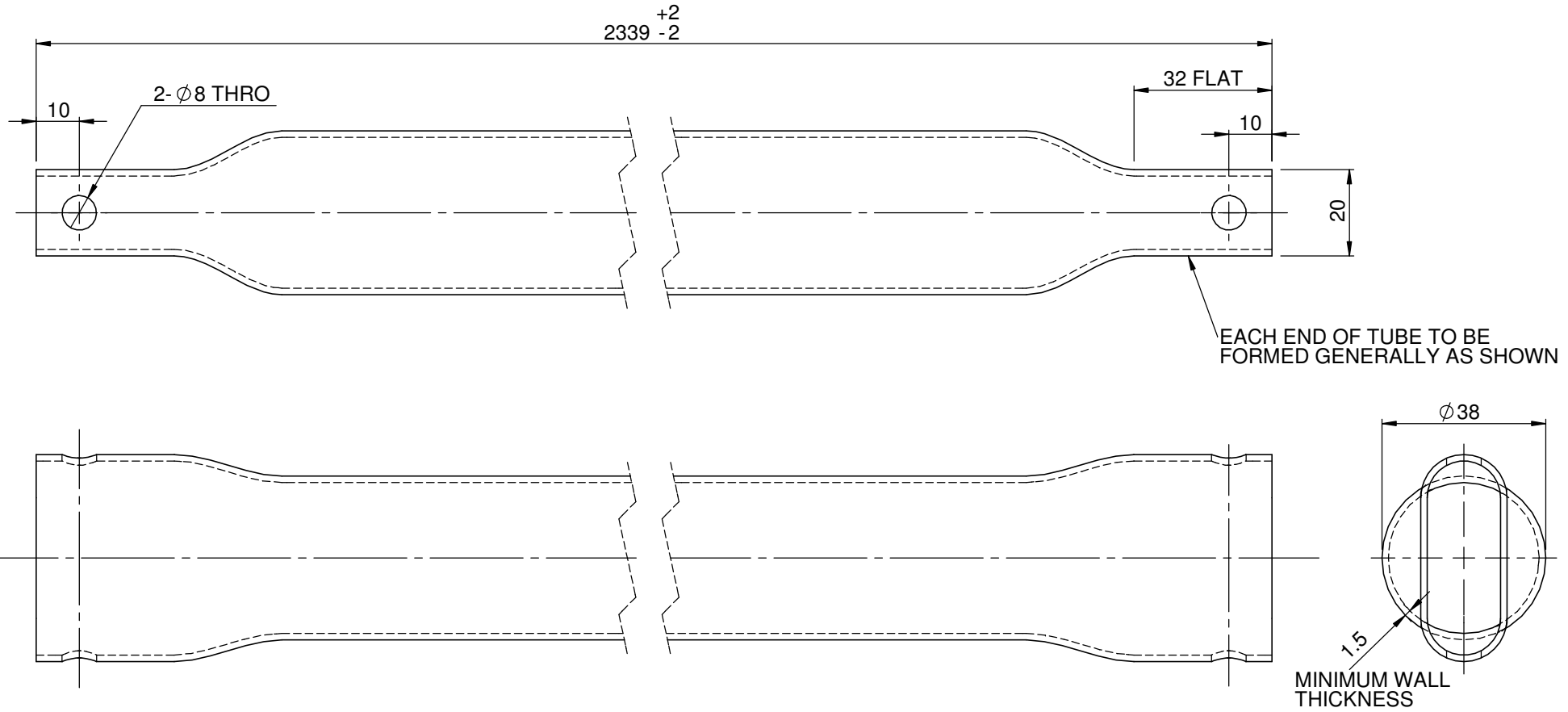

0	31/1/14	ISSUED FOR MANUFACTURE	GC		
REV	DATE	DESCRIPTION	DRN	CHKD	APPR

TOLERANCES - UNLESS STATED OTHERWISE		TITLE:			
UNTOLERANCED DIMENSIONS		<b>HORIZONTAL TUBE</b>			
CUTTING LENGTHS					
FABRICATION	UP TO 300mm	+/- 2mm	NAME	SIGNATURE	DATE
	UP TO 1000mm	+/- 1mm	DRAWN	G. CRICK	31/1/14
	1001mm & ABOVE	+/- 2mm			
	ANGULAR	+/- 3mm	CHK'D		
MACHINING	+/- 0.2mm	FINISH:			
GAUGE	+/- 10%	NONE			
WEIGHT	+/- 10% (DUE TO MATERIAL PROPERTIES & TOLERANCES)				

**ZNDUK**<sub>e</sub>

CARBON STEEL

Drw / Stockcode No. **ZND548-2** Revision **0**

THE COMPANY RETAIN THE RIGHT TO PERIODICALLY ALTER INFORMATION WITHIN THIS DRAWING SHEET AND WILL ATTEMPT TO NOTIFY ALL PARTIES CONCERNED OF ANY CHANGES AND THE INFORMATION ON THIS SHEET SHOULD NOT BE REPRODUCED WITHOUT THEIR WRITTEN CONSENT.

ALL DIMENSIONS IN MILLIMETRES  
REMOVE ALL SHARP EDGES

THIRD ANGLE PROJECTION  
DO NOT SCALE DRAWING

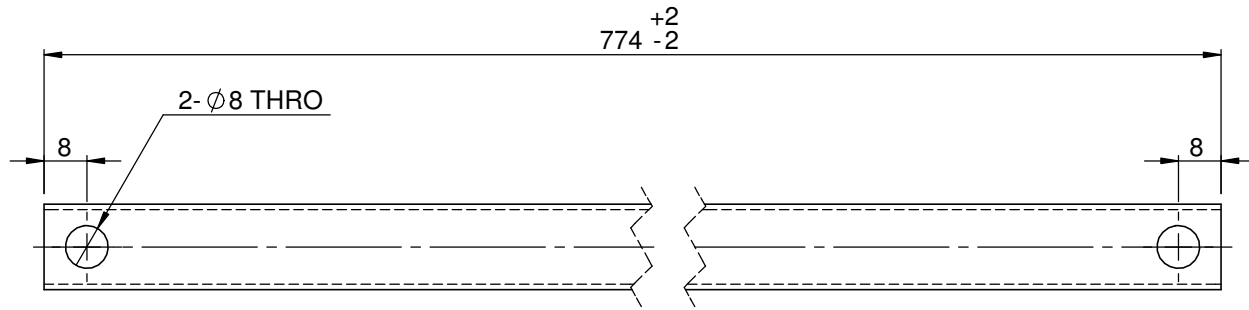

0	31/1/14	ISSUED FOR MANUFACTURE	GC		
REV	DATE	DESCRIPTION	DRN	CHKD	APPR

TOLERANCES - UNLESS STATED OTHERWISE		TITLE:
UNTOLERANCED DIMENSIONS	+/- 2mm	INFILL TUBE
CUTTING LENGTHS	+/- 2mm	
FABRICATION	UP TO 300mm	+/- 1mm
	UP TO 1000mm	+/- 2mm
	1001mm & ABOVE	+/- 3mm
	ANGULAR	+/- 1°
MACHINING	+/- 0.2mm	
GAUGE	+/- 10%	
WEIGHT	+/- 10% (DUE TO MATERIAL PROPERTIES & TOLERANCES)	

NAME	SIGNATURE	DATE	MATERIAL:
G. CRICK		31/1/14	CARBON STEEL
CHK'D			
FINISH:			NONE

**ZNDUK**<sub>e</sub>

Drw / Stockcode No. **ZND548-3** Revision **0**

THE COMPANY RETAIN THE RIGHT TO PERIODICALLY ALTER INFORMATION WITHIN THIS DRAWING SHEET AND WILL ATTEMPT TO NOTIFY ALL PARTIES CONCERNED OF ANY CHANGES AND THE INFORMATION ON THIS SHEET SHOULD NOT BE REPRODUCED WITHOUT THEIR WRITTEN CONSENT.

ALL DIMENSIONS IN MILLIMETRES  
REMOVE ALL SHARP EDGES

THIRD ANGLE PROJECTION  
DO NOT SCALE DRAWING

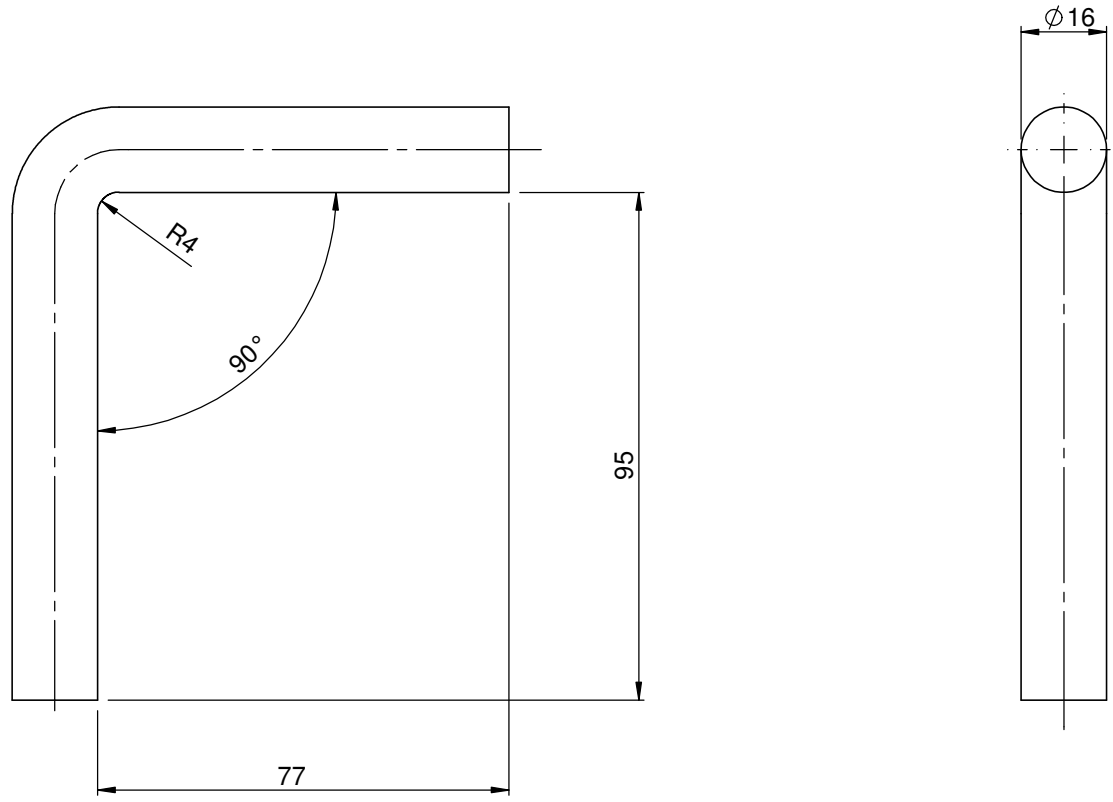

0	31/1/14	ISSUED FOR MANUFACTURE	GC		
REV	DATE	DESCRIPTION	DRN	CHKD	APPR

TOLERANCES - UNLESS STATED OTHERWISE		TITLE: HOOK			
UNTOLERANCED DIMENSIONS	+/- 2mm	DRAWN: G. CRICK, DATE: 31/1/14			
CUTTING LENGTHS	+/- 2mm				
FABRICATION	UP TO 300mm	+/- 1mm	MATERIAL: CARBON STEEL		
	UP TO 1000mm	+/- 2mm			
	1001mm & ABOVE	+/- 3mm			
	ANGULAR	+/- 1°	CHK'D		
MACHINING	+/- 0.2mm	FINISH: NONE			
GAUGE	+/- 10%				
WEIGHT	+/- 10% (DUE TO MATERIAL PROPERTIES & TOLERANCES)				



Drw / Stockcode No.	Revision
ZND548-4	0

THE COMPANY RETAIN THE RIGHT TO PERIODICALLY ALTER INFORMATION WITHIN THIS DRAWING SHEET AND WILL ATTEMPT TO NOTIFY ALL PARTIES CONCERNED OF ANY CHANGES AND THE INFORMATION ON THIS SHEET SHOULD NOT BE REPRODUCED WITHOUT THEIR WRITTEN CONSENT.

ALL DIMENSIONS IN MILLIMETRES  
REMOVE ALL SHARP EDGES

THIRD ANGLE PROJECTION  
DO NOT SCALE DRAWING

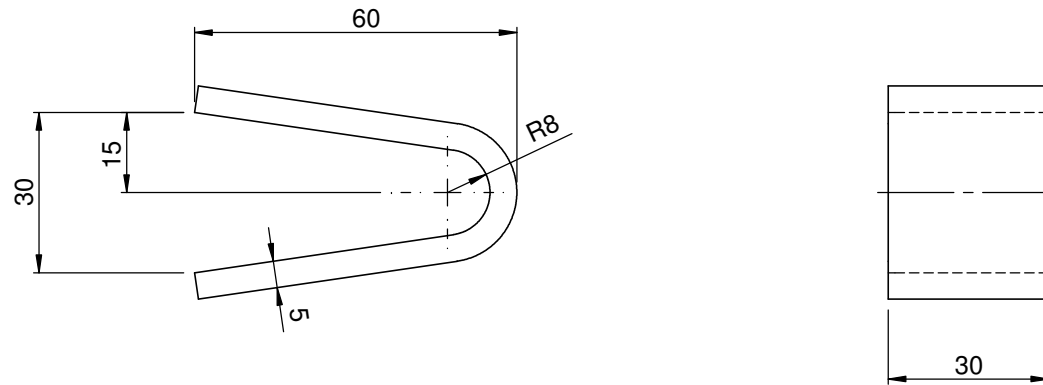

0	31/1/14	ISSUED FOR MANUFACTURE	GC		
REV	DATE	DESCRIPTION	DRN	CHKD	APPR

TOLERANCES - UNLESS STATED OTHERWISE	
UNTOLERANCED DIMENSIONS	+/- 2mm
CUTTING LENGTHS	+/- 2mm
FABRICATION	
UP TO 300mm	+/- 1mm
UP TO 1000mm	+/- 2mm
1001mm & ABOVE	+/- 3mm
ANGULAR	+/- 1°
MACHINING	+/- 0.2mm
GAUGE	+/- 10%
WEIGHT	+/- 10% (DUE TO MATERIAL PROPERTIES & TOLERANCES)

TITLE: HOOK			
NAME	SIGNATURE	DATE	MATERIAL:
G. CRICK		31/1/14	CARBON STEEL
FINISH:	NONE		

**ZNDUK**<sub>e</sub>

Drw / Stockcode No. **ZND548-4** Revision **0**

THE COMPANY RETAIN THE RIGHT TO PERIODICALLY ALTER INFORMATION WITHIN THIS DRAWING SHEET AND WILL ATTEMPT TO NOTIFY ALL PARTIES CONCERNED OF ANY CHANGES AND THE INFORMATION ON THIS SHEET SHOULD NOT BE REPRODUCED WITHOUT THEIR WRITTEN CONSENT.