

ALL DIMENSIONS IN MILLIMETRES
REMOVE ALL SHARP EDGES

THIRD ANGLE PROJECTION
DO NOT SCALE DRAWING

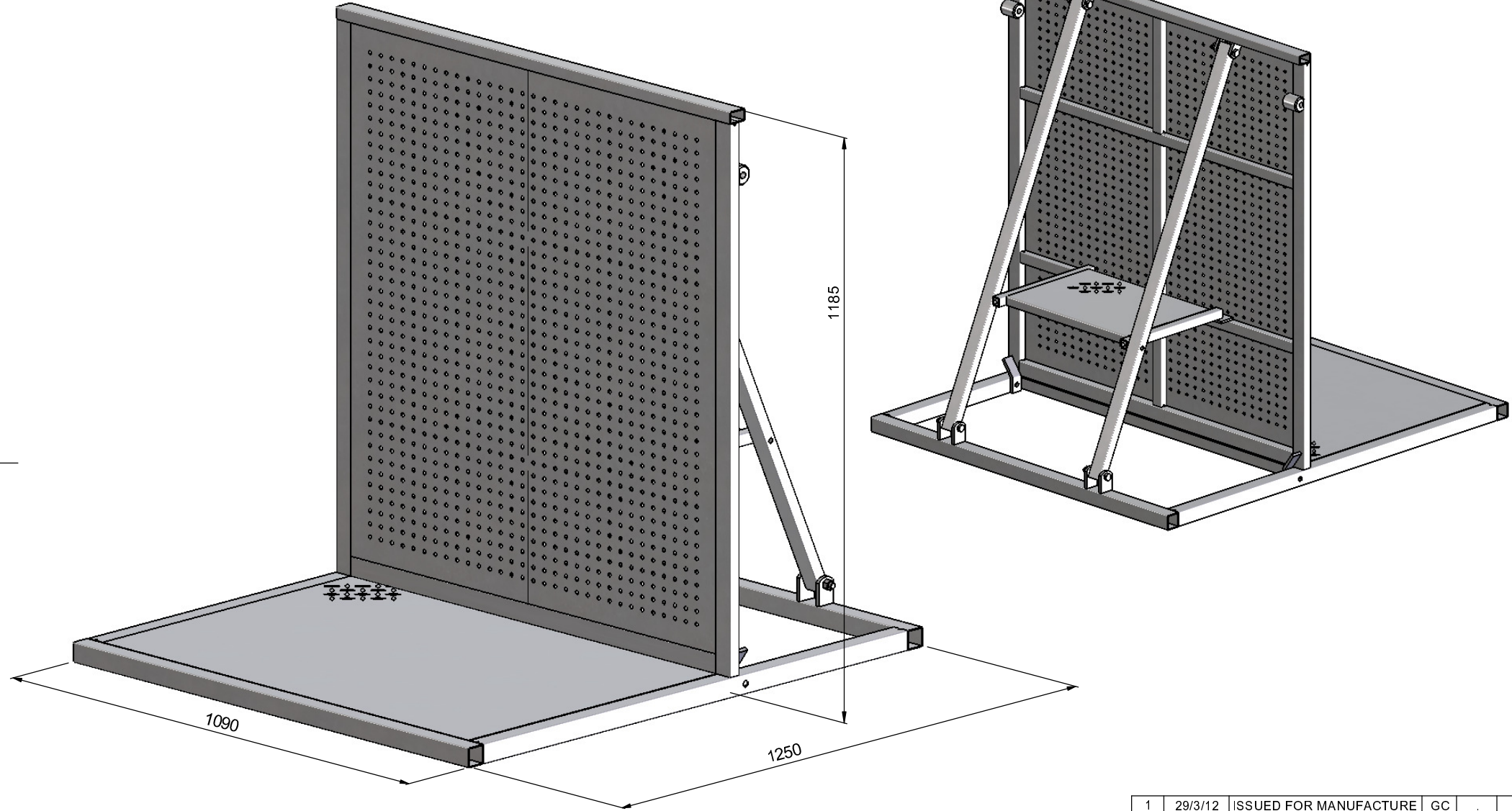

1	29/3/12	ISSUED FOR MANUFACTURE	GC		
0	17/12/11	ISSUED FOR MANUFACTURE	GC		
REV	DATE	DESCRIPTION	DRN	CHKD	APPR

TITLE: STAGE BARRIER			
DRAWN	NAME	SIGNATURE	DATE
CHK'D	G. CRICK		5/12/11
FINISH:	HOT DIPPED GALVANISED		
MATERIAL: CARBON STEEL			
WEIGHT: 62.5 Kg			

ZNDDE

Dwg/Stock No. **ZND508** Revision **1**

CODE No. 1070

THE COMPANY RETAIN THE RIGHT TO PERIODICALLY ALTER INFORMATION WITHIN THIS DRAWING SHEET AND WILL ATTEMPT TO NOTIFY ALL PARTIES CONCERNED OF ANY CHANGES AND THE INFORMATION ON THIS SHEET SHOULD NOT BE REPRODUCED WITHOUT THEIR WRITTEN CONSENT.

UNLESS STATED OTHERWISE		
GENERAL TOLERANCES:		
FABRICATION	UP TO 1000mm	+/- 2mm
	1001mm & ABOVE	+/- 3mm
ANGULAR	+/- 0.5 DEGREE	
WEIGHT	+/- 10% (DUE TO MATERIAL PROPERTIES & TOLERANCES)	

1 2 3 4 5 6 7 8
 ALL DIMENSIONS IN MILLIMETRES
 REMOVE ALL SHARP EDGES

THIRD ANGLE PROJECTION
 DO NOT SCALE DRAWING

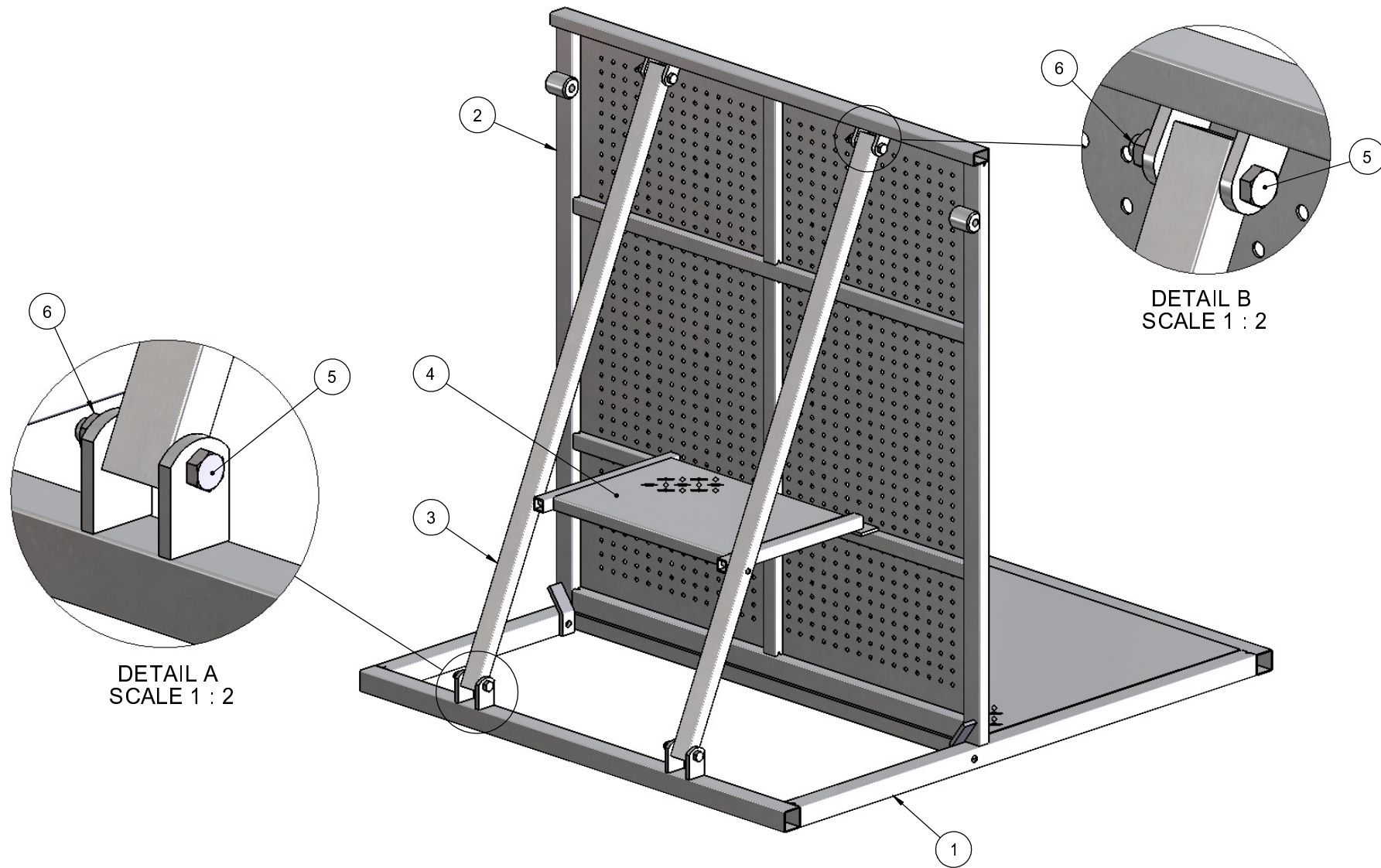

ITEM No.	PART No.	DESCRIPTION	QTY
1	ZND508-1	BASE	1
2	ZND508-2	FRONT	1
3	ZND508-3	BRACE	2
4	ZND508-4	STEP	1
5		M12 x 80 Lg HEX HEAD SET SCREW GALV	4
6		M12 LOCK NUT GALV	4

REV	DATE	DESCRIPTION	DRN	CHKD	APPR
1	29/3/12	ISSUED FOR MANUFACTURE	GC		
0	17/12/11	ISSUED FOR MANUFACTURE	GC		

TITLE: STAGE BARRIER			
NAME	SIGNATURE	DATE	MATERIAL:
G. CRICK		5/12/10	CARBON STEEL
CHK'D			
FINISH:	HOT DIPPED GALVANISED		



Dwg/Stock No.	Revision
ZND508-GA	1

CODE No. 1070

THE COMPANY RETAIN THE RIGHT TO PERIODICALLY ALTER INFORMATION WITHIN THIS DRAWING SHEET AND WILL ATTEMPT TO NOTIFY ALL PARTIES CONCERNED OF ANY CHANGES AND THE INFORMATION ON THIS SHEET SHOULD NOT BE REPRODUCED WITHOUT THEIR WRITTEN CONSENT.

UNLESS STATED OTHERWISE		
GENERAL TOLERANCES:		
FABRICATION	UP TO 1000mm	+/- 2mm
	1001mm & ABOVE	+/- 3mm
ANGULAR	+/- 0.5 DEGREE	
WEIGHT	+/- 10% (DUE TO MATERIAL PROPERTIES & TOLERANCES)	

1 2 3 4 5 6 7 8
 ALL DIMENSIONS IN MILLIMETRES
 REMOVE ALL SHARP EDGES

THIRD ANGLE PROJECTION
 DO NOT SCALE DRAWING

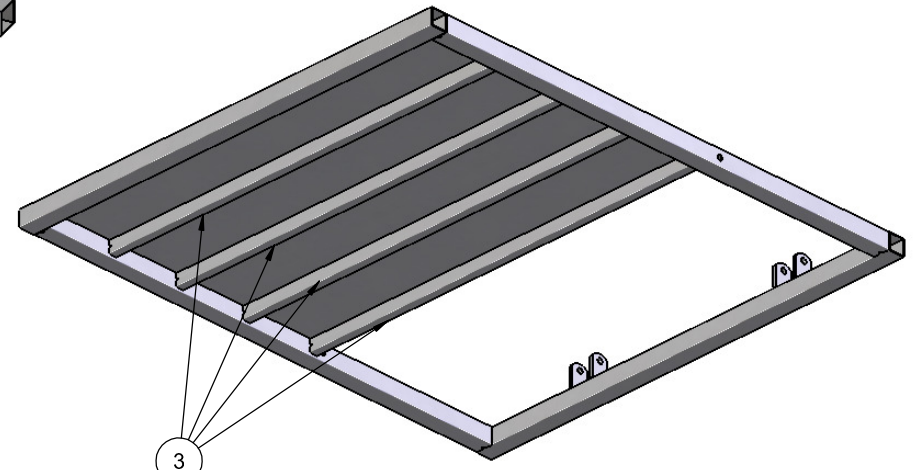
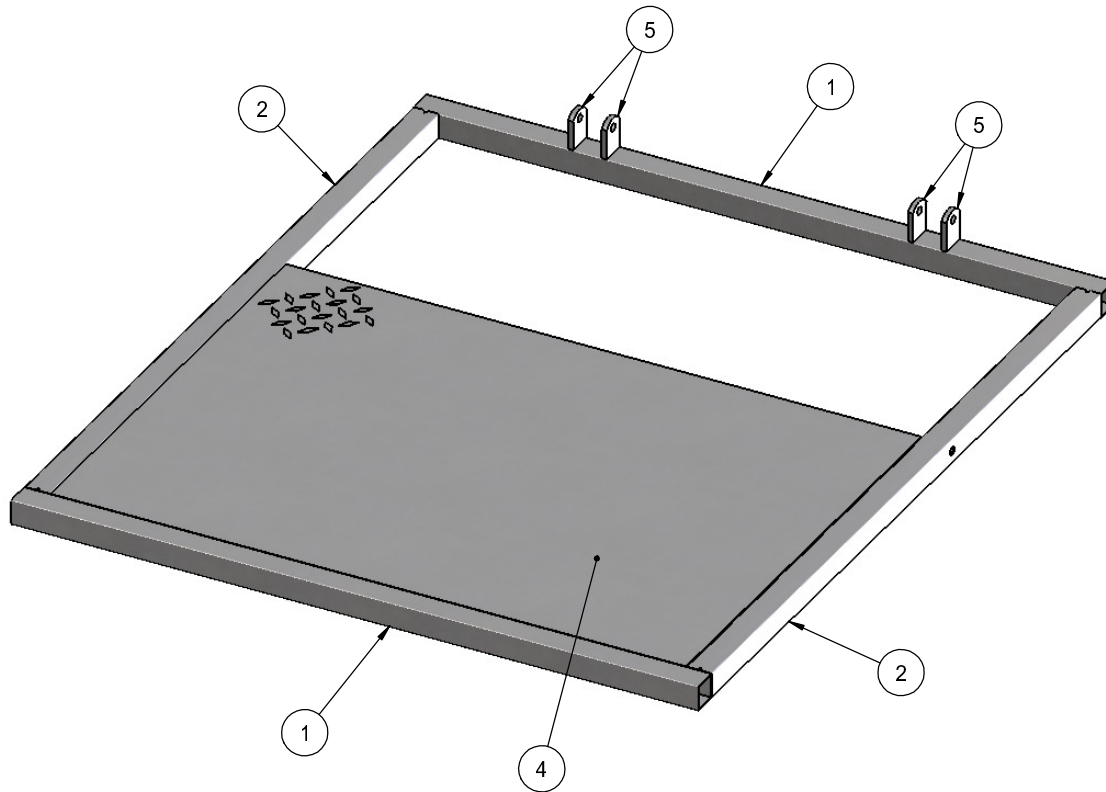

VIEW ON UNDERSIDE

ITEM No.	PART No.	DESCRIPTION	QTY	MATERIAL SIZE
1	ZND508-1-1	BASE TUBE PT 1	2	40 x 40 x 2 SHS x 1090 Lg
2	ZND508-1-2	BASE TUBE PT 2	2	SEE DETAIL
3	ZND508-1-3	BASE TUBE PT 3	4	SEE DETAIL
4	ZND508-1-4	FLOOR PLATE	1	SEE DETAIL
5	ZND508-1-5	PIVOT BRACKET	4	SEE DETAIL

UNLESS STATED OTHERWISE		
GENERAL TOLERANCES:		
FABRICATION	UP TO 1000mm	+/- 2mm
	1001mm & ABOVE	+/- 3mm
ANGULAR	+/- 0.5 DEGREE	
WEIGHT	+/- 10% (DUE TO MATERIAL PROPERTIES & TOLERANCES)	

TITLE: **STAGE BARRIER
 BASE - FABRICATION SHT 1**

NAME	SIGNATURE	DATE
G. CRICK		6/12/11

FINISH: **HOT DIPPED GALVANISED**

MATERIAL: **CARBON STEEL**

1	29/3/12	ISSUED FOR MANUFACTURE	GC		
0	17/12/11	ISSUED FOR MANUFACTURE	GC		
REV	DATE	DESCRIPTION	DRN	CHKD	APPR

ZNDDE

Dwg/Stock No. **ZND508-1 - FAB SHT 1** Revision **1**

THE COMPANY RETAIN THE RIGHT TO PERIODICALLY ALTER INFORMATION WITHIN THIS DRAWING SHEET AND WILL ATTEMPT TO NOTIFY ALL PARTIES CONCERNED OF ANY CHANGES AND THE INFORMATION ON THIS SHEET SHOULD NOT BE REPRODUCED WITHOUT THEIR WRITTEN CONSENT.

ALL DIMENSIONS IN MILLIMETRES
REMOVE ALL SHARP EDGES

THIRD ANGLE PROJECTION
DO NOT SCALE DRAWING

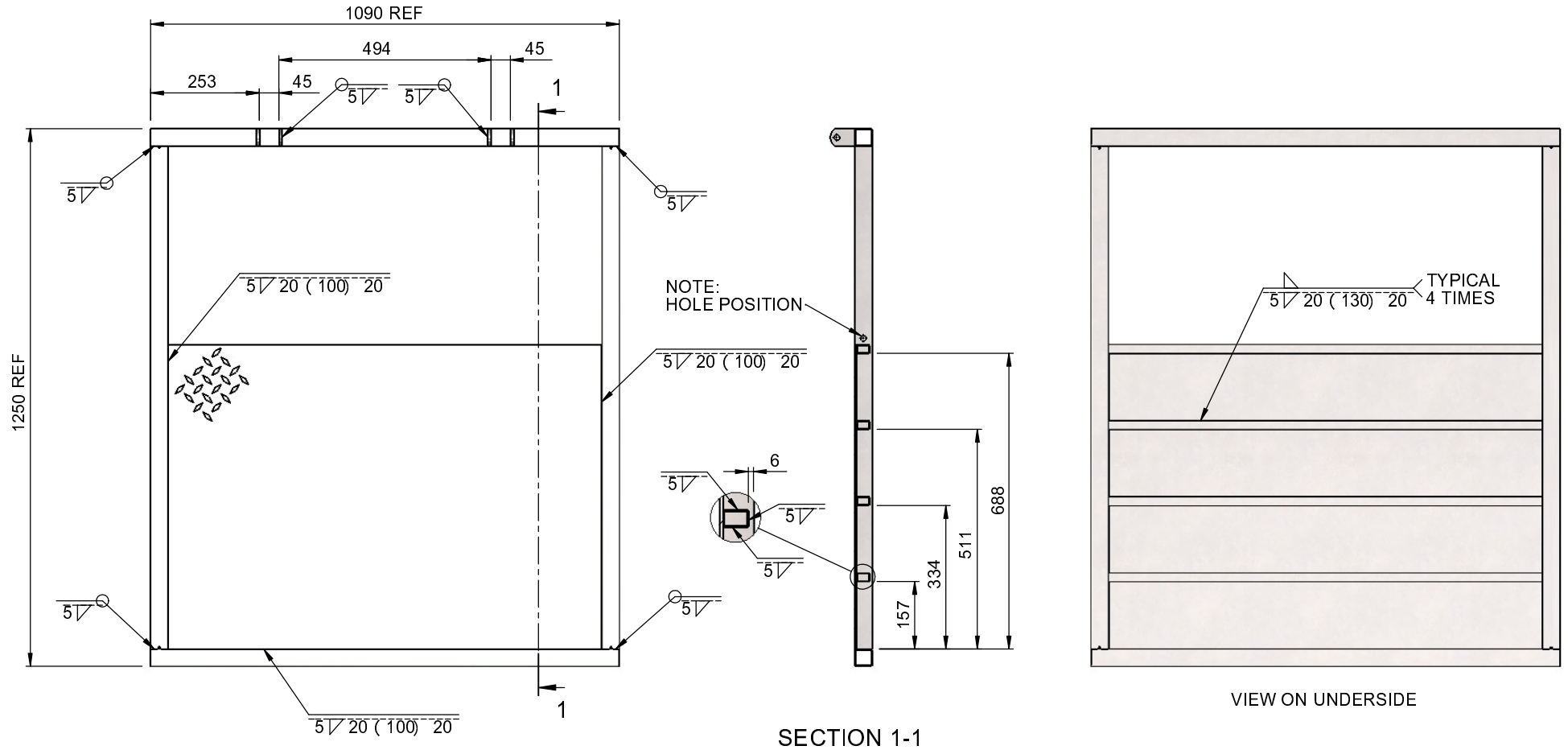

SECTION 1-1

VIEW ON UNDERSIDE

1	29/3/12	ISSUED FOR MANUFACTURE	GC		
0	17/12/11	ISSUED FOR MANUFACTURE	GC		
REV	DATE	DESCRIPTION	DRN	CHKD	APPR

TITLE: **STAGE BARRIER
BASE - FABRICATION SHT 2**

UNLESS STATED OTHERWISE		
GENERAL TOLERANCES:		
FABRICATION	UP TO 1000mm	+/- 2mm
	1001mm & ABOVE	+/- 3mm
ANGULAR	+/- 0.5 DEGREE	
WEIGHT	+/- 10% (DUE TO MATERIAL PROPERTIES & TOLERANCES)	

NAME	SIGNATURE	DATE
G. CRICK		6/12/11
CHK'D		
FINISH:	NONE	

MATERIAL:
CARBON STEEL



Dwg/Stock No. **ZND508-1 - FAB SHT 2** Revision **1**

THE COMPANY RETAIN THE RIGHT TO PERIODICALLY ALTER INFORMATION WITHIN THIS DRAWING SHEET AND WILL ATTEMPT TO NOTIFY ALL PARTIES CONCERNED OF ANY CHANGES AND THE INFORMATION ON THIS SHEET SHOULD NOT BE REPRODUCED WITHOUT THEIR WRITTEN CONSENT.

ALL DIMENSIONS IN MILLIMETRES
REMOVE ALL SHARP EDGES

THIRD ANGLE PROJECTION
DO NOT SCALE DRAWING

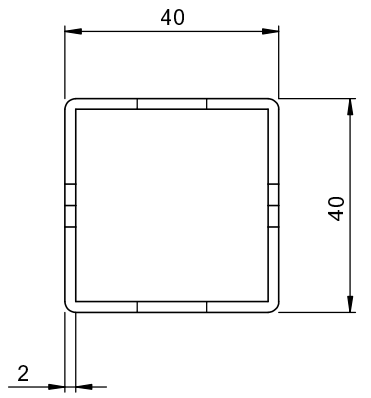
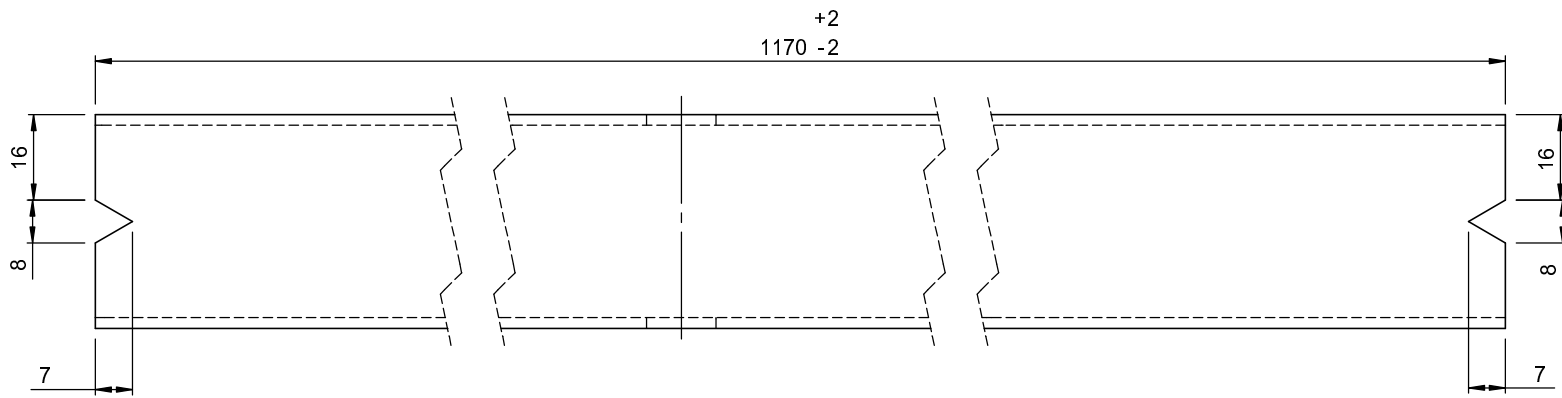
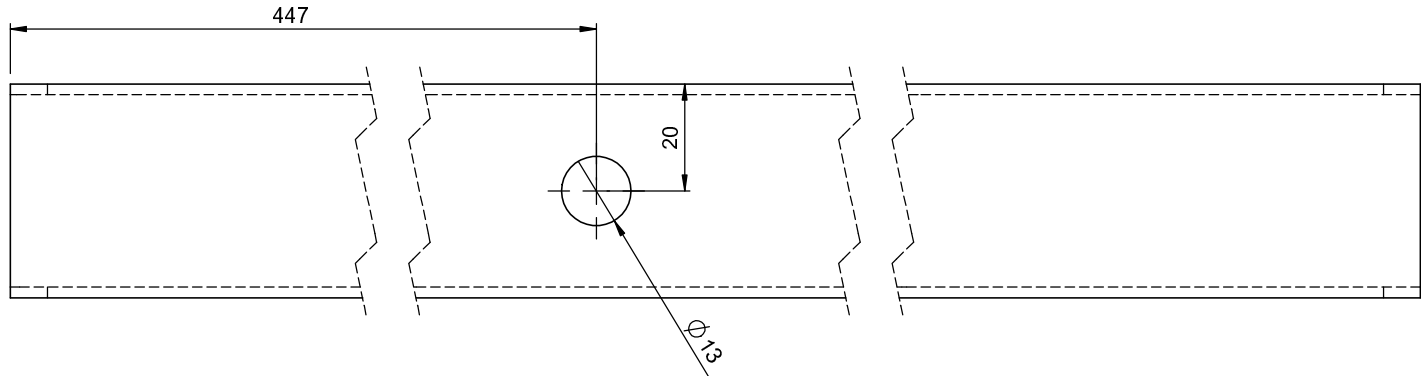

1	29/3/12	ISSUED FOR MANUFACTURE	GC		
0	17/12/11	ISSUED FOR MANUFACTURE	GC		
REV	DATE	DESCRIPTION	DRN	CHKD	APPR

TITLE: **BASE TUBE PT 2**

UNLESS STATED OTHERWISE		
GENERAL TOLERANCES:		
FABRICATION	UP TO 1000mm	+/- 2mm
	1001mm & ABOVE	+/- 3mm
ANGULAR	+/- 0.5 DEGREE	
WEIGHT	+/- 10% (DUE TO MATERIAL PROPERTIES & TOLERANCES)	

DRAWN	NAME	SIGNATURE	DATE
CHK'D	G. CRICK		6/12/11
FINISH: NONE			

MATERIAL: CARBON STEEL



Dwg/Stock No. **ZND508-1-2** Revision **1**

THE COMPANY RETAIN THE RIGHT TO PERIODICALLY ALTER INFORMATION WITHIN THIS DRAWING SHEET AND WILL ATTEMPT TO NOTIFY ALL PARTIES CONCERNED OF ANY CHANGES AND THE INFORMATION ON THIS SHEET SHOULD NOT BE REPRODUCED WITHOUT THEIR WRITTEN CONSENT.

ALL DIMENSIONS IN MILLIMETRES
REMOVE ALL SHARP EDGES

THIRD ANGLE PROJECTION
DO NOT SCALE DRAWING

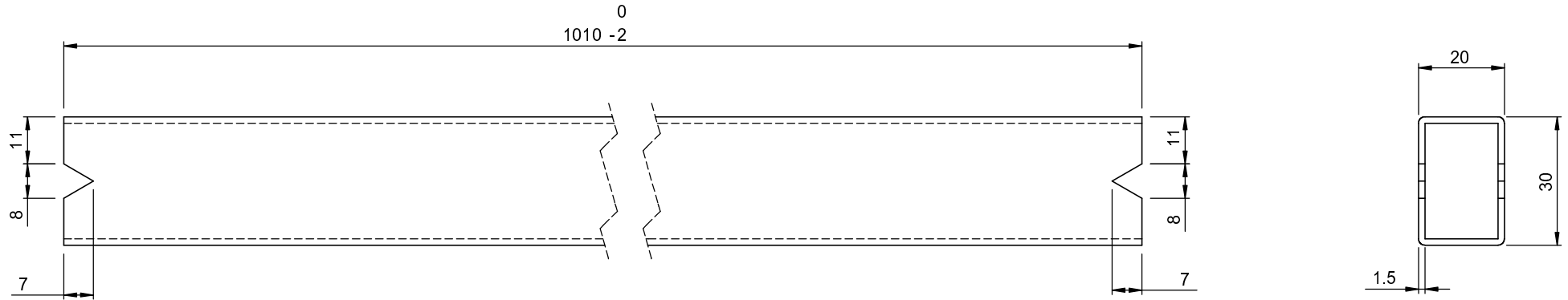

1	29/3/12	ISSUED FOR MANUFACTURE	GC	.	.
0	17/12/11	ISSUED FOR MANUFACTURE	GC	.	.
REV	DATE	DESCRIPTION	DRN	CHKD	APPR

TITLE: **BASE TUBE PT 3**

UNLESS STATED OTHERWISE		
GENERAL TOLERANCES:		
FABRICATION	UP TO 1000mm	+/- 2mm
	1001mm & ABOVE	+/- 3mm
ANGULAR	+/- 0.5 DEGREE	
WEIGHT	+/- 10% (DUE TO MATERIAL PROPERTIES & TOLERANCES)	

NAME	SIGNATURE	DATE
G. CRICK		6/12/11
CHK'D		
FINISH:		
NONE		

MATERIAL: **CARBON STEEL**



Dwg/Stock No.	Revision
ZND508-1-3	1

THE COMPANY RETAIN THE RIGHT TO PERIODICALLY ALTER INFORMATION WITHIN THIS DRAWING SHEET AND WILL ATTEMPT TO NOTIFY ALL PARTIES CONCERNED OF ANY CHANGES AND THE INFORMATION ON THIS SHEET SHOULD NOT BE REPRODUCED WITHOUT THEIR WRITTEN CONSENT.

ALL DIMENSIONS IN MILLIMETRES
REMOVE ALL SHARP EDGES

THIRD ANGLE PROJECTION
DO NOT SCALE DRAWING

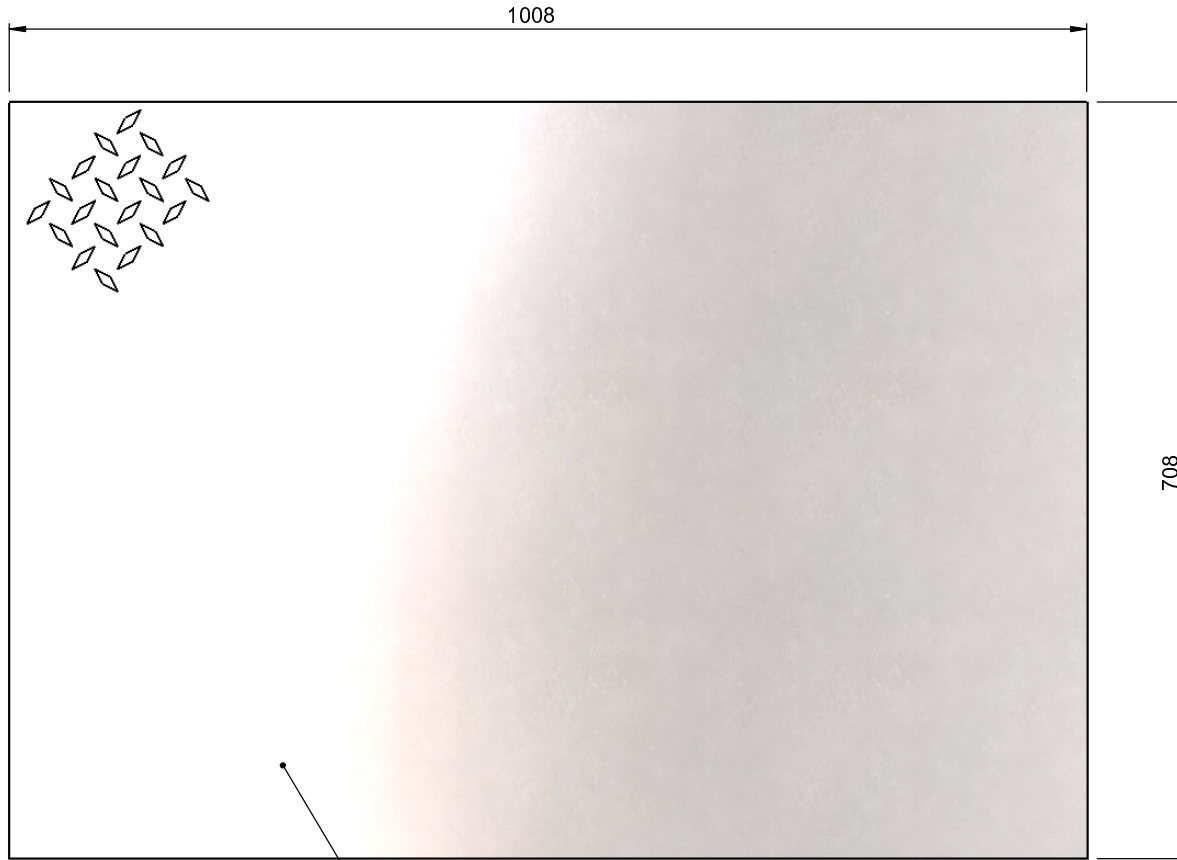

4mm THICK DURBAR PLATE
OR EQUIVALENT

1	29/3/12	ISSUED FOR MANUFACTURE	GC	.	.
0	17/12/11	ISSUED FOR MANUFACTURE	GC	.	.
REV	DATE	DESCRIPTION	DRN	CHKD	APPR

TITLE: **BASE FLOOR PLATE**

UNLESS STATED OTHERWISE		
GENERAL TOLERANCES:		
FABRICATION	UP TO 1000mm	+/- 2mm
	1001mm & ABOVE	+/- 3mm
ANGULAR	+/- 0.5 DEGREE	
WEIGHT	+/- 10% (DUE TO MATERIAL PROPERTIES & TOLERANCES)	

DRAWN	NAME	SIGNATURE	DATE
CHK'D	G. CRICK		6/12/11
FINISH:			
NONE			

MATERIAL:
CARBON STEEL



Dwg/Stock No. **ZND508-1-4** Revision **1**

THE COMPANY RETAIN THE RIGHT TO PERIODICALLY ALTER INFORMATION WITHIN THIS DRAWING SHEET AND WILL ATTEMPT TO NOTIFY ALL PARTIES CONCERNED OF ANY CHANGES AND THE INFORMATION ON THIS SHEET SHOULD NOT BE REPRODUCED WITHOUT THEIR WRITTEN CONSENT.

1
2
3
4
5
6
7
8

ALL DIMENSIONS IN MILLIMETRES
REMOVE ALL SHARP EDGES

THIRD ANGLE PROJECTION
DO NOT SCALE DRAWING

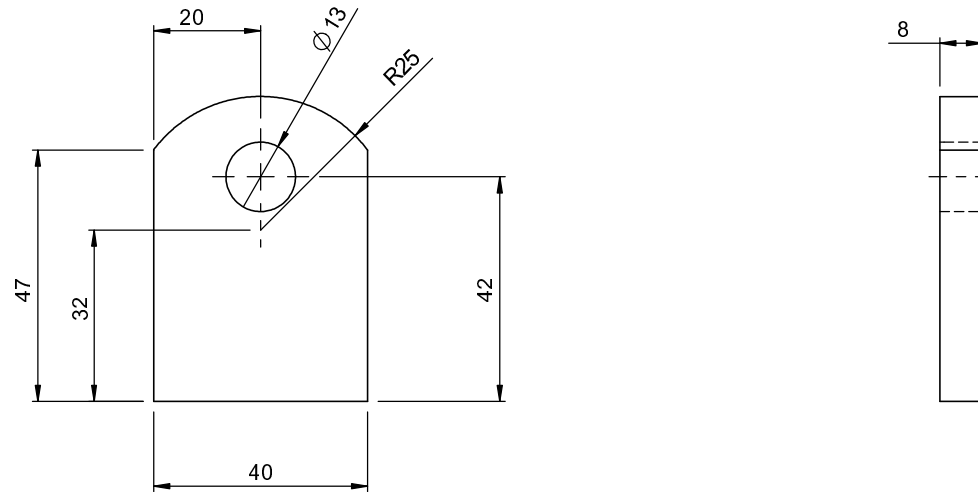

1	29/3/12	ISSUED FOR MANUFACTURE	GC	.	.
0	17/12/11	ISSUED FOR MANUFACTURE	GC	.	.
REV	DATE	DESCRIPTION	DRN	CHKD	APPR

TITLE: **PIVOT BRACKET**

UNLESS STATED OTHERWISE		
GENERAL TOLERANCES:		
FABRICATION	UP TO 1000mm	+/- 2mm
	1001mm & ABOVE	+/- 3mm
ANGULAR	+/- 0.5 DEGREE	
WEIGHT	+/- 10% (DUE TO MATERIAL PROPERTIES & TOLERANCES)	

NAME	SIGNATURE	DATE
G. CRICK		6/12/11
CHK'D		
FINISH:		
NONE		

MATERIAL:
CARBON STEEL



Dwg/Stock No. **ZND508-1-5** Revision **1**

THE COMPANY RETAIN THE RIGHT TO PERIODICALLY ALTER INFORMATION WITHIN THIS DRAWING SHEET AND WILL ATTEMPT TO NOTIFY ALL PARTIES CONCERNED OF ANY CHANGES AND THE INFORMATION ON THIS SHEET SHOULD NOT BE REPRODUCED WITHOUT THEIR WRITTEN CONSENT.

ALL DIMENSIONS IN MILLIMETRES
REMOVE ALL SHARP EDGES

THIRD ANGLE PROJECTION
DO NOT SCALE DRAWING

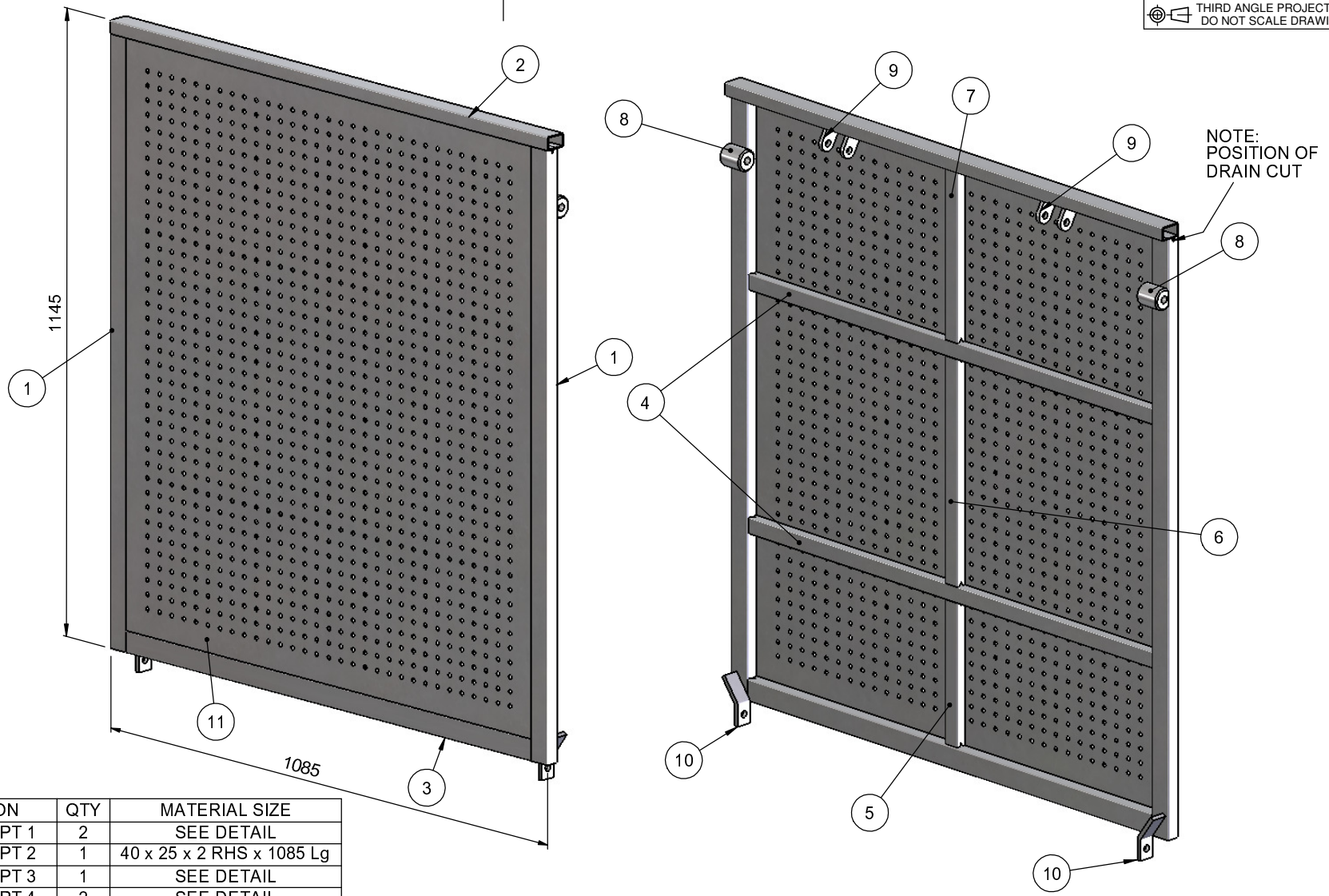

NOTE:
POSITION OF
DRAIN CUT

ITEM No.	PART No.	DESCRIPTION	QTY	MATERIAL SIZE
1	ZND508-2-1	FRAME TUBE PT 1	2	SEE DETAIL
2	ZND508-2-2	FRAME TUBE PT 2	1	40 x 25 x 2 RHS x 1085 Lg
3	ZND508-2-3	FRAME TUBE PT 3	1	SEE DETAIL
4	ZND508-2-4	FRAME TUBE PT 4	2	SEE DETAIL
5	ZND508-2-5	FRAME TUBE PT 5	1	SEE DETAIL
6	ZND508-2-6	FRAME TUBE PT 6	1	SEE DETAIL
7	ZND508-2-7	FRAME TUBE PT 7	1	SEE DETAIL
8	ZND508-2-8	LOCKING BOSS	2	SEE DETAIL
9	ZND508-2-9	LEG PIVOT BRACKET	4	SEE DETAIL
10	ZND508-2-10	LOCATION BRACKET	2	SEE DETAIL
11	ZND508-2-11	FRONT PLATE	1	SEE DETAIL

REV	DATE	DESCRIPTION	DRN	CHKD	APPR
1	29/3/12	ISSUED FOR MANUFACTURE	GC		
0	17/12/11	ISSUED FOR MANUFACTURE	GC		

TITLE: **STAGE BARRIER
FRONT - FABRICATION SHT 1**

ZNDUK
Mangham Road Barbot Hall Ind Estate Rotherham S61 4RJ
Tel 01709 521100 Fax: 01709 521111 Web: www.znduk.com

UNLESS STATED OTHERWISE		
GENERAL TOLERANCES:		
FABRICATION	UP TO 1000mm	+/- 2mm
	1001mm & ABOVE	+/- 3mm
ANGULAR	+/- 0.5 DEGREE	
WEIGHT	+/- 10% (DUE TO MATERIAL PROPERTIES & TOLERANCES)	

NAME	SIGNATURE	DATE
G. CRICK		6/12/11

FINISH: **HOT DIPPED GALVANISED**

MATERIAL: **CARBON STEEL**

Dwg/Stock No. **ZND508-2 - FAB SHT 2** Revision **1**

THE COMPANY RETAIN THE RIGHT TO PERIODICALLY ALTER INFORMATION WITHIN THIS DRAWING SHEET AND WILL ATTEMPT TO NOTIFY ALL PARTIES CONCERNED OF ANY CHANGES AND THE INFORMATION ON THIS SHEET SHOULD NOT BE REPRODUCED WITHOUT THEIR WRITTEN CONSENT.

ALL DIMENSIONS IN MILLIMETRES
REMOVE ALL SHARP EDGES

THIRD ANGLE PROJECTION
DO NOT SCALE DRAWING

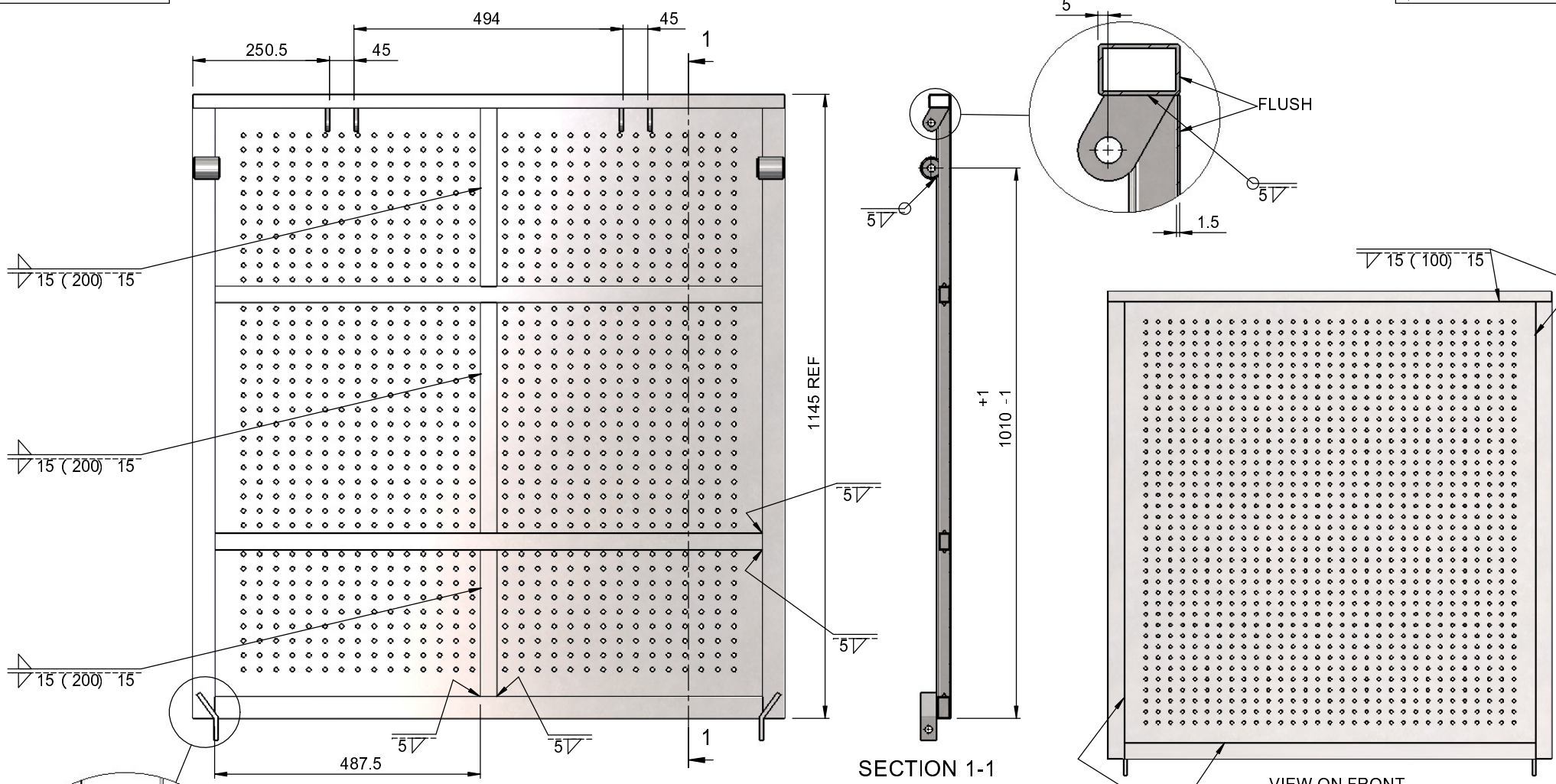

SECTION 1-1

VIEW ON FRONT

1	29/3/12	ISSUED FOR MANUFACTURE	GC		
0	17/12/11	ISSUED FOR MANUFACTURE	GC		
REV	DATE	DESCRIPTION	DRN	CHKD	APPR

TITLE: **STAGE BARRIER
FRONT - FABRICATION SHT 2**

ZNDUK
Mangham Road Barbot Hall Ind Estate Rotherham S61 4RJ
Tel 01709 521100 Fax: 01709 521111 Web: www.znduk.com

UNLESS STATED OTHERWISE		
GENERAL TOLERANCES:		
FABRICATION	UP TO 1000mm	+/- 2mm
	1001mm & ABOVE	+/- 3mm
ANGULAR	+/- 0.5 DEGREE	
WEIGHT	+/- 10% (DUE TO MATERIAL PROPERTIES & TOLERANCES)	

NAME	SIGNATURE	DATE
G. CRICK		6/12/11
CHKD		
FINISH:	HOT DIPPED GALVANISED	

MATERIAL:
CARBON STEEL

Dwg/Stock No. **ZND508-2 - FAB SHT 2** Revision **1**

THE COMPANY RETAIN THE RIGHT TO PERIODICALLY ALTER INFORMATION WITHIN THIS DRAWING SHEET AND WILL ATTEMPT TO NOTIFY ALL PARTIES CONCERNED OF ANY CHANGES AND THE INFORMATION ON THIS SHEET SHOULD NOT BE REPRODUCED WITHOUT THEIR WRITTEN CONSENT.

ALL DIMENSIONS IN MILLIMETRES
REMOVE ALL SHARP EDGES

THIRD ANGLE PROJECTION
DO NOT SCALE DRAWING

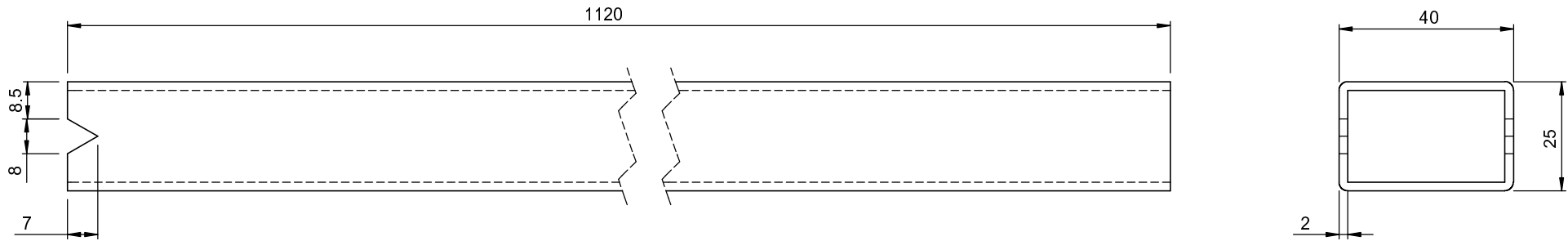

1	29/3/12	ISSUED FOR MANUFACTURE	GC		
0	17/12/11	ISSUED FOR MANUFACTURE	GC		
REV	DATE	DESCRIPTION	DRN	CHKD	APPR

TITLE: **FRAME TUBE PT 1**

UNLESS STATED OTHERWISE		
GENERAL TOLERANCES:		
FABRICATION	UP TO 1000mm	+/- 2mm
	1001mm & ABOVE	+/- 3mm
ANGULAR	+/- 0.5 DEGREE	
WEIGHT	+/- 10% (DUE TO MATERIAL PROPERTIES & TOLERANCES)	

NAME	SIGNATURE	DATE
G. CRICK		6/12/11
CHK'D		
FINISH:		
NONE		

MATERIAL:
CARBON STEEL

ZNDUK
Mangham Road Barbot Hall Ind Estate Rotherham S61 4RJ
Tel 01709 521100 Fax: 01709 521111 Web: www.znduk.com

Dwg/Stock No. **ZND508-2-1** Revision **1**

THE COMPANY RETAIN THE RIGHT TO PERIODICALLY ALTER INFORMATION WITHIN THIS DRAWING SHEET AND WILL ATTEMPT TO NOTIFY ALL PARTIES CONCERNED OF ANY CHANGES AND THE INFORMATION ON THIS SHEET SHOULD NOT BE REPRODUCED WITHOUT THEIR WRITTEN CONSENT.

ALL DIMENSIONS IN MILLIMETRES
REMOVE ALL SHARP EDGES

THIRD ANGLE PROJECTION
DO NOT SCALE DRAWING

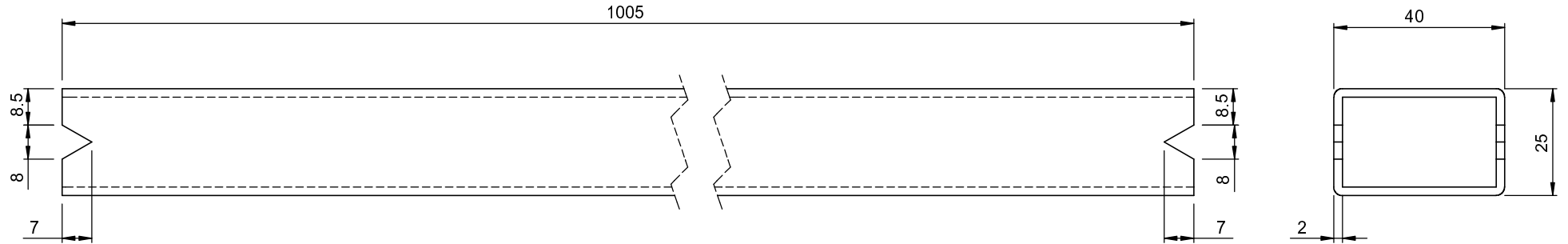

1	29/3/12	ISSUED FOR MANUFACTURE	GC	.	.
0	17/12/11	ISSUED FOR MANUFACTURE	GC	.	.
REV	DATE	DESCRIPTION	DRN	CHKD	APPR

TITLE: **FRAME TUBE PT 3**

UNLESS STATED OTHERWISE		
GENERAL TOLERANCES:		
FABRICATION	UP TO 1000mm	+/- 2mm
	1001mm & ABOVE	+/- 3mm
ANGULAR	+/- 0.5 DEGREE	
WEIGHT	+/- 10% (DUE TO MATERIAL PROPERTIES & TOLERANCES)	

DRAWN	NAME	SIGNATURE	DATE
CHK'D	G. CRICK		6/12/11
FINISH:	NONE		

MATERIAL:
CARBON STEEL

ZNDUK
Mangham Road Barbot Hall Ind Estate Rotherham S61 4RJ
Tel 01709 521100 Fax: 01709 521111 Web: www.znduk.com

Dwg/Stock No. **ZND508-2-3** Revision **1**

THE COMPANY RETAIN THE RIGHT TO PERIODICALLY ALTER INFORMATION WITHIN THIS DRAWING SHEET AND WILL ATTEMPT TO NOTIFY ALL PARTIES CONCERNED OF ANY CHANGES AND THE INFORMATION ON THIS SHEET SHOULD NOT BE REPRODUCED WITHOUT THEIR WRITTEN CONSENT.

ALL DIMENSIONS IN MILLIMETRES
REMOVE ALL SHARP EDGES

THIRD ANGLE PROJECTION
DO NOT SCALE DRAWING

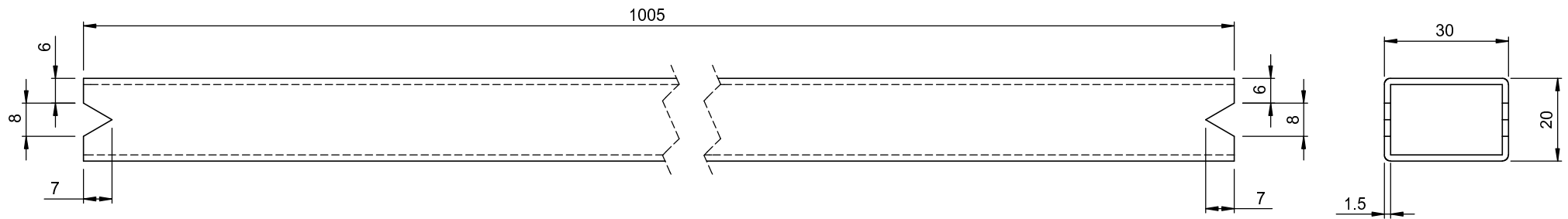

1	29/3/12	ISSUED FOR MANUFACTURE	GC		
0	17/12/11	ISSUED FOR MANUFACTURE	GC		
REV	DATE	DESCRIPTION	DRN	CHKD	APPR

TITLE: **FRAME TUBE PT 4**

UNLESS STATED OTHERWISE		
GENERAL TOLERANCES:		
FABRICATION	UP TO 1000mm	+/- 2mm
	1001mm & ABOVE	+/- 3mm
ANGULAR	+/- 0.5 DEGREE	
WEIGHT	+/- 10% (DUE TO MATERIAL PROPERTIES & TOLERANCES)	

NAME	SIGNATURE	DATE
G. CRICK		6/12/11
CHK'D		
FINISH:		
NONE		

MATERIAL:
CARBON STEEL

ZNDUK

Mangham Road Barbot Hall Ind Estate Rotherham S61 4RJ
Tel 01709 521100 Fax: 01709 521111 Web: www.znduk.com

Dwg/Stock No.	Revision
ZND508-2-4	1

THE COMPANY RETAIN THE RIGHT TO PERIODICALLY ALTER INFORMATION WITHIN THIS DRAWING SHEET AND WILL ATTEMPT TO NOTIFY ALL PARTIES CONCERNED OF ANY CHANGES AND THE INFORMATION ON THIS SHEET SHOULD NOT BE REPRODUCED WITHOUT THEIR WRITTEN CONSENT.

ALL DIMENSIONS IN MILLIMETRES
REMOVE ALL SHARP EDGES

THIRD ANGLE PROJECTION
DO NOT SCALE DRAWING

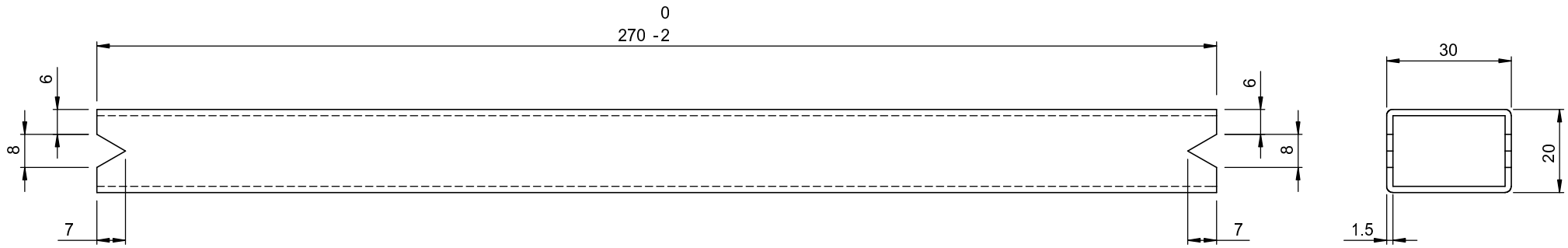

1	29/3/12	ISSUED FOR MANUFACTURE	GC		
0	17/12/11	ISSUED FOR MANUFACTURE	GC		
REV	DATE	DESCRIPTION	DRN	CHKD	APPR

TITLE: **FRAME TUBE PT 5**

UNLESS STATED OTHERWISE		
GENERAL TOLERANCES:		
FABRICATION	UP TO 1000mm	+/- 2mm
	1001mm & ABOVE	+/- 3mm
ANGULAR	+/- 0.5 DEGREE	
WEIGHT	+/- 10% (DUE TO MATERIAL PROPERTIES & TOLERANCES)	

	NAME	SIGNATURE	DATE
DRAWN	G. CRICK		6/12/11
CHK'D			
FINISH:	NONE		

MATERIAL: **CARBON STEEL**

ZNDUK

Mangham Road Barbot Hall Ind Estate Rotherham S61 4RJ
Tel 01709 521100 Fax: 01709 521111 Web: www.znduk.com

Dwg/Stock No.	Revision
ZND508-2-5	1

THE COMPANY RETAIN THE RIGHT TO PERIODICALLY ALTER INFORMATION WITHIN THIS DRAWING SHEET AND WILL ATTEMPT TO NOTIFY ALL PARTIES CONCERNED OF ANY CHANGES AND THE INFORMATION ON THIS SHEET SHOULD NOT BE REPRODUCED WITHOUT THEIR WRITTEN CONSENT.

ALL DIMENSIONS IN MILLIMETRES
REMOVE ALL SHARP EDGES

THIRD ANGLE PROJECTION
DO NOT SCALE DRAWING

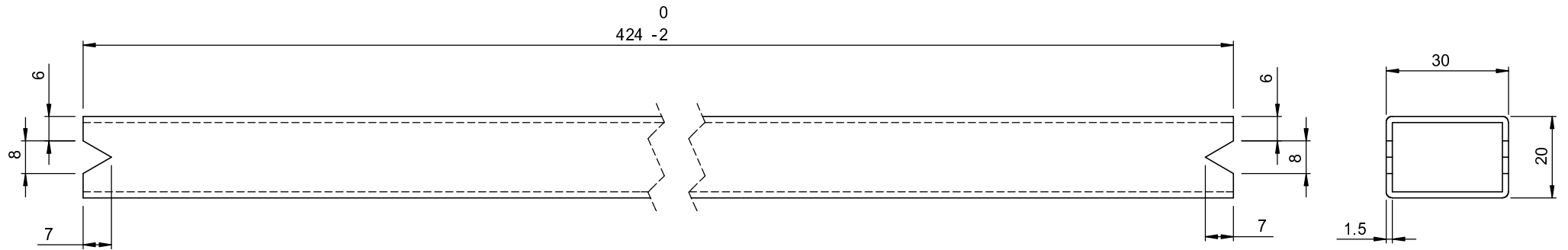

1	29/3/12	ISSUED FOR MANUFACTURE	GC		
0	17/12/11	ISSUED FOR MANUFACTURE	GC		
REV	DATE	DESCRIPTION	DRN	CHKD	APPR

TITLE: **FRAME TUBE PT 6**

UNLESS STATED OTHERWISE		
GENERAL TOLERANCES:		
FABRICATION	UP TO 1000mm	+/- 2mm
	1001mm & ABOVE	+/- 3mm
ANGULAR	+/- 0.5 DEGREE	
WEIGHT	+/- 10% (DUE TO MATERIAL PROPERTIES & TOLERANCES)	

	NAME	SIGNATURE	DATE
DRAWN	G. CRICK		6/12/11
CHK'D			
FINISH:	NONE		

MATERIAL: **CARBON STEEL**

ZNDUK
Mangham Road Barbot Hall Ind Estate Rotherham S61 4RJ
Tel 01709 521100 Fax: 01709 521111 Web: www.znduk.com

Dwg/Stock No.	Revision
ZND508-2-6	1

THE COMPANY RETAIN THE RIGHT TO PERIODICALLY ALTER INFORMATION WITHIN THIS DRAWING SHEET AND WILL ATTEMPT TO NOTIFY ALL PARTIES CONCERNED OF ANY CHANGES AND THE INFORMATION ON THIS SHEET SHOULD NOT BE REPRODUCED WITHOUT THEIR WRITTEN CONSENT.

ALL DIMENSIONS IN MILLIMETRES
REMOVE ALL SHARP EDGES

THIRD ANGLE PROJECTION
DO NOT SCALE DRAWING

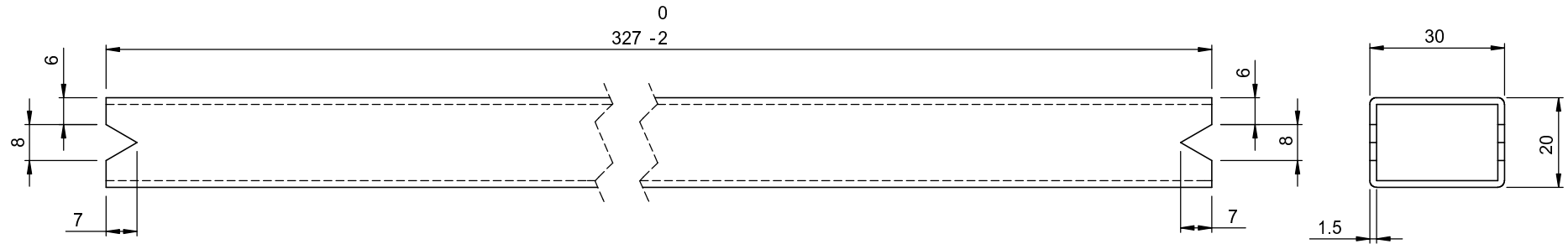

1	29/3/12	ISSUED FOR MANUFACTURE	GC		
0	17/12/11	ISSUED FOR MANUFACTURE	GC		
REV	DATE	DESCRIPTION	DRN	CHKD	APPR

TITLE: **FRAME TUBE PT 7**

UNLESS STATED OTHERWISE		
GENERAL TOLERANCES:		
FABRICATION	UP TO 1000mm	+/- 2mm
	1001mm & ABOVE	+/- 3mm
ANGULAR	+/- 0.5 DEGREE	
WEIGHT	+/- 10% (DUE TO MATERIAL PROPERTIES & TOLERANCES)	

NAME	SIGNATURE	DATE
G. CRICK		6/12/11
CHK'D		
FINISH:	NONE	

MATERIAL: **CARBON STEEL**

ZNDUK
Mangham Road Barbot Hall Ind Estate Rotherham S61 4RJ
Tel 01709 521100 Fax: 01709 521111 Web: www.znduk.com

Dwg/Stock No.	Revision
ZND508-2-7	1

THE COMPANY RETAIN THE RIGHT TO PERIODICALLY ALTER INFORMATION WITHIN THIS DRAWING SHEET AND WILL ATTEMPT TO NOTIFY ALL PARTIES CONCERNED OF ANY CHANGES AND THE INFORMATION ON THIS SHEET SHOULD NOT BE REPRODUCED WITHOUT THEIR WRITTEN CONSENT.

1
2
3
4
5
6
7
8

ALL DIMENSIONS IN MILLIMETRES
REMOVE ALL SHARP EDGES

THIRD ANGLE PROJECTION
DO NOT SCALE DRAWING

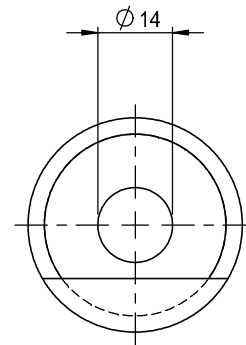
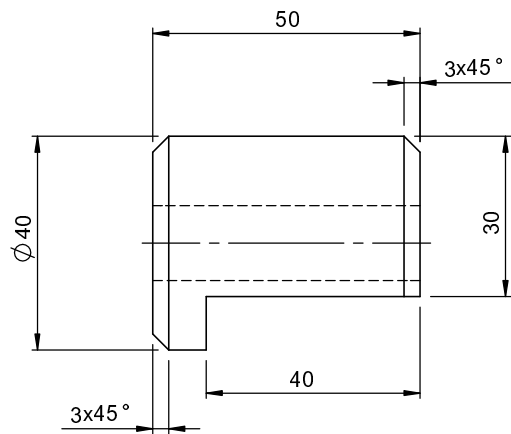

1	29/3/12	ISSUED FOR MANUFACTURE	GC		
0	17/12/11	ISSUED FOR MANUFACTURE	GC		
REV	DATE	DESCRIPTION	DRN	CHKD	APPR

TITLE: **LOCKING BOSS**

UNLESS STATED OTHERWISE		
GENERAL TOLERANCES:		
FABRICATION	UP TO 1000mm	+/- 2mm
	1001mm & ABOVE	+/- 3mm
ANGULAR	+/- 0.5 DEGREE	
WEIGHT	+/- 10% (DUE TO MATERIAL PROPERTIES & TOLERANCES)	

	NAME	SIGNATURE	DATE
DRAWN	G. CRICK		6/12/11
CHK'D			
FINISH:	NONE		

MATERIAL:
CARBON STEEL

ZNDUK

Mangham Road Barbot Hall Ind Estate Rotherham S61 4RJ
Tel 01709 521100 Fax: 01709 521111 Web: www.znduk.com

Dwg/Stock No.	Revision
ZND508-2-8	1

THE COMPANY RETAIN THE RIGHT TO PERIODICALLY ALTER INFORMATION WITHIN THIS DRAWING SHEET AND WILL ATTEMPT TO NOTIFY ALL PARTIES CONCERNED OF ANY CHANGES AND THE INFORMATION ON THIS SHEET SHOULD NOT BE REPRODUCED WITHOUT THEIR WRITTEN CONSENT.

1
2
3
4
5
6
7
8

ALL DIMENSIONS IN MILLIMETRES
REMOVE ALL SHARP EDGES

THIRD ANGLE PROJECTION
DO NOT SCALE DRAWING

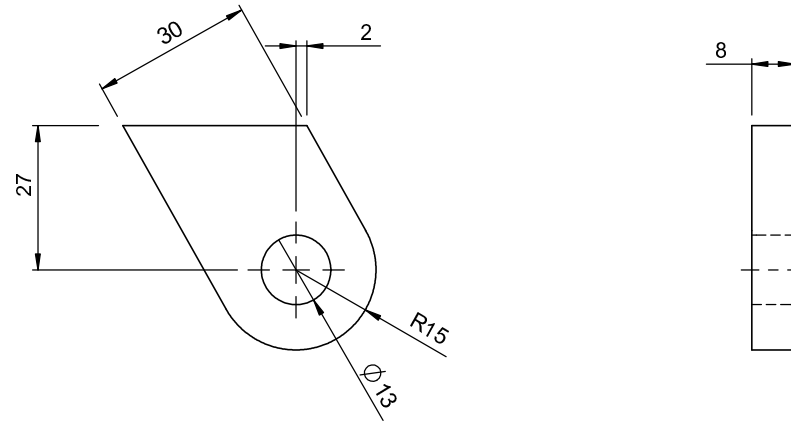

1	29/3/12	ISSUED FOR MANUFACTURE	GC		
0	17/12/11	ISSUED FOR MANUFACTURE	GC		
REV	DATE	DESCRIPTION	DRN	CHKD	APPR

TITLE: **LEG PIVOT BRACKET**

UNLESS STATED OTHERWISE		
GENERAL TOLERANCES:		
FABRICATION	UP TO 1000mm	+/- 2mm
	1001mm & ABOVE	+/- 3mm
ANGULAR	+/- 0.5 DEGREE	
WEIGHT	+/- 10% (DUE TO MATERIAL PROPERTIES & TOLERANCES)	

NAME	SIGNATURE	DATE
G. CRICK		6/12/11
CHK'D		
FINISH:		
NONE		

MATERIAL:
CARBON STEEL

ZNDUK
Mangham Road Barbot Hall Ind Estate Rotherham S61 4RJ
Tel 01709 521100 Fax: 01709 521111 Web: www.znduk.com

Dwg/Stock No. **ZND508-2-9** Revision **1**

THE COMPANY RETAIN THE RIGHT TO PERIODICALLY ALTER INFORMATION WITHIN THIS DRAWING SHEET AND WILL ATTEMPT TO NOTIFY ALL PARTIES CONCERNED OF ANY CHANGES AND THE INFORMATION ON THIS SHEET SHOULD NOT BE REPRODUCED WITHOUT THEIR WRITTEN CONSENT.

1
2
3
4
5
6
7
8

ALL DIMENSIONS IN MILLIMETRES
REMOVE ALL SHARP EDGES

THIRD ANGLE PROJECTION
DO NOT SCALE DRAWING

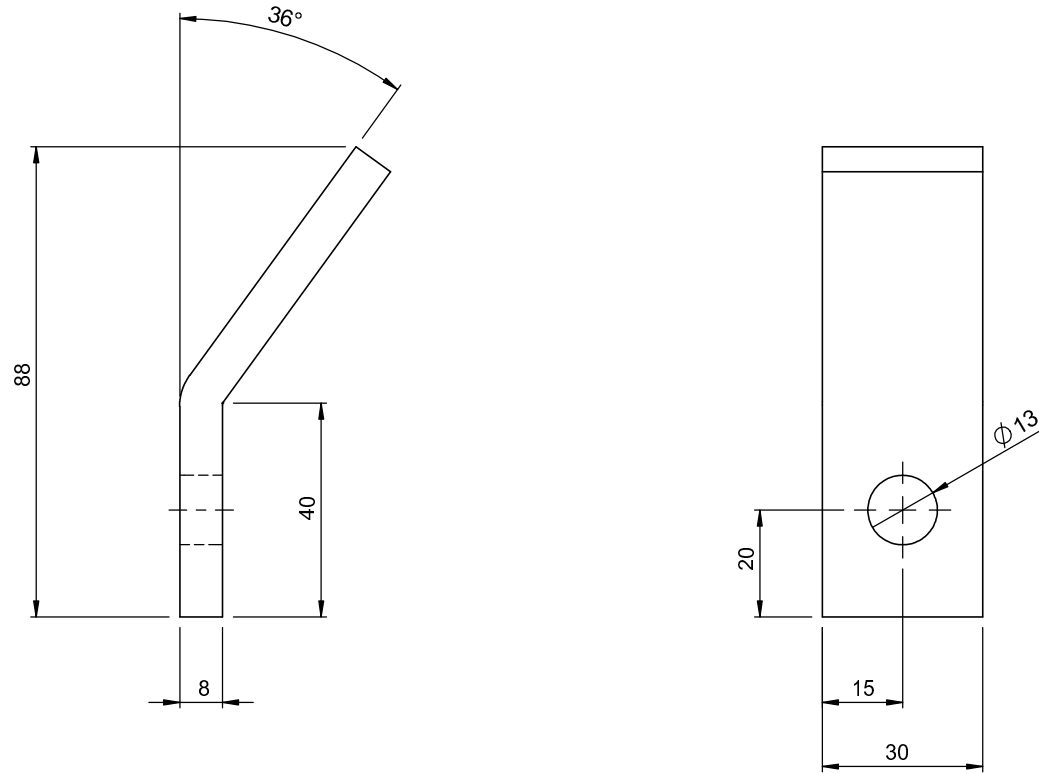

1	29/3/12	ISSUED FOR MANUFACTURE	GC		
0	17/12/11	ISSUED FOR MANUFACTURE	GC		
REV	DATE	DESCRIPTION	DRN	CHKD	APPR

TITLE: LOCATION BRACKET

UNLESS STATED OTHERWISE		
GENERAL TOLERANCES:		
FABRICATION	UP TO 1000mm	+/- 2mm
	1001mm & ABOVE	+/- 3mm
ANGULAR	+/- 0.5 DEGREE	
WEIGHT	+/- 10% (DUE TO MATERIAL PROPERTIES & TOLERANCES)	

	NAME	SIGNATURE	DATE
DRAWN	G. CRICK		6/12/11
CHK'D			
FINISH:	NONE		

MATERIAL: CARBON STEEL

ZNDUK

Mangham Road Barbot Hall Ind Estate Rotherham S61 4RJ
Tel 01709 521100 Fax: 01709 521111 Web: www.znduk.com

Dwg/Stock No.	Revision
ZND508-2-10	1

THE COMPANY RETAIN THE RIGHT TO PERIODICALLY ALTER INFORMATION WITHIN THIS DRAWING SHEET AND WILL ATTEMPT TO NOTIFY ALL PARTIES CONCERNED OF ANY CHANGES AND THE INFORMATION ON THIS SHEET SHOULD NOT BE REPRODUCED WITHOUT THEIR WRITTEN CONSENT.

ALL DIMENSIONS IN MILLIMETRES
REMOVE ALL SHARP EDGES

THIRD ANGLE PROJECTION
DO NOT SCALE DRAWING

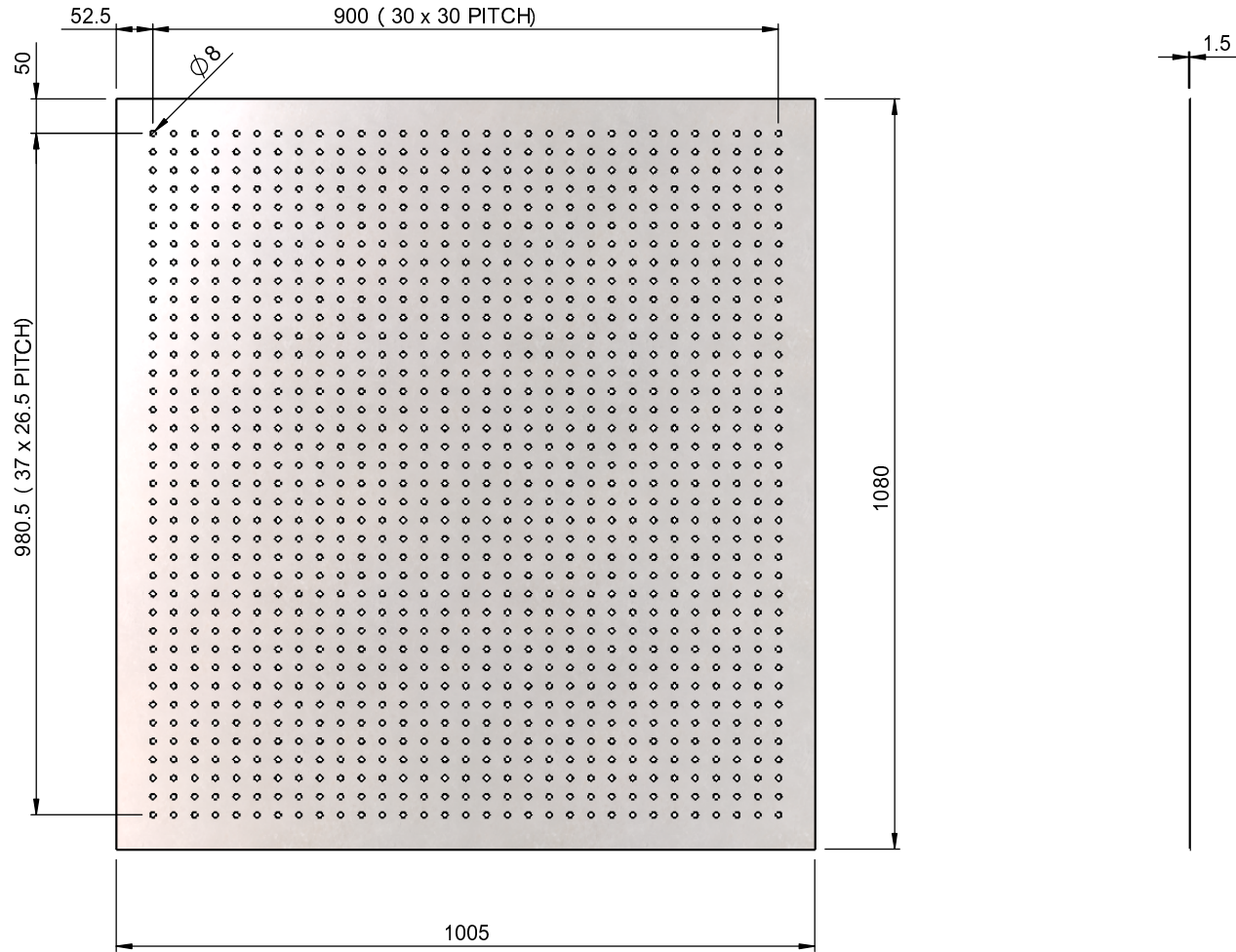

1	29/3/12	ISSUED FOR MANUFACTURE	GC		
0	17/12/11	ISSUED FOR MANUFACTURE	GC		
REV	DATE	DESCRIPTION	DRN	CHKD	APPR

TITLE: **FRONT PLATE**

UNLESS STATED OTHERWISE		
GENERAL TOLERANCES:		
FABRICATION	UP TO 1000mm	+/- 2mm
	1001mm & ABOVE	+/- 3mm
ANGULAR	+/- 0.5 DEGREE	
WEIGHT	+/- 10% (DUE TO MATERIAL PROPERTIES & TOLERANCES)	

DRAWN	NAME	SIGNATURE	DATE
CHKD	G. CRICK		6/12/11
FINISH:			
NONE			

MATERIAL:
CARBON STEEL

ZNDUK
Mangham Road Barbot Hall Ind Estate Rotherham S61 4RJ
Tel 01709 521100 Fax: 01709 521111 Web: www.znduk.com

Dwg/Stock No. **ZND508-2-11** Revision **1**

THE COMPANY RETAIN THE RIGHT TO PERIODICALLY ALTER INFORMATION WITHIN THIS DRAWING SHEET AND WILL ATTEMPT TO NOTIFY ALL PARTIES CONCERNED OF ANY CHANGES AND THE INFORMATION ON THIS SHEET SHOULD NOT BE REPRODUCED WITHOUT THEIR WRITTEN CONSENT.

ALL DIMENSIONS IN MILLIMETRES
REMOVE ALL SHARP EDGES

THIRD ANGLE PROJECTION
DO NOT SCALE DRAWING

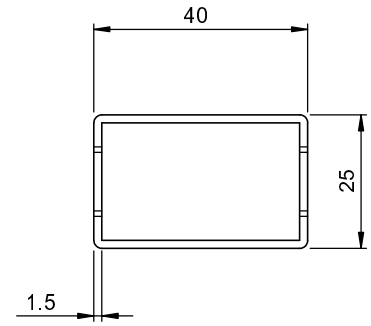
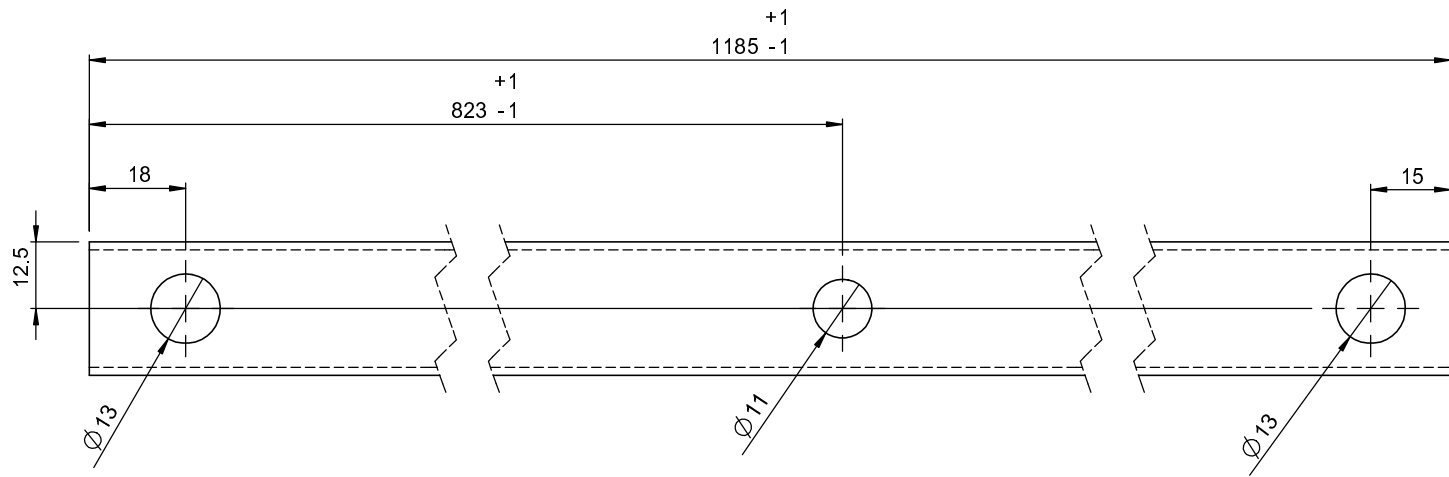

1	29/3/12	ISSUED FOR MANUFACTURE	GC		
0	17/12/11	ISSUED FOR MANUFACTURE	GC		
REV	DATE	DESCRIPTION	DRN	CHKD	APPR

TITLE: **STAGE BARRIER BRACE**

UNLESS STATED OTHERWISE		
GENERAL TOLERANCES:		
FABRICATION	UP TO 1000mm	+/- 2mm
	1001mm & ABOVE	+/- 3mm
ANGULAR	+/- 0.5 DEGREE	
WEIGHT	+/- 10% (DUE TO MATERIAL PROPERTIES & TOLERANCES)	

DRAWN	NAME	SIGNATURE	DATE
CHK'D	G. CRICK		6/12/11
FINISH:	HOT DIPPED GALVANISED		

MATERIAL: **CARBON STEEL**

ZNDUK
Mangham Road Barbot Hall Ind Estate Rotherham S61 4RJ
Tel 01709 521100 Fax: 01709 521111 Web: www.znduk.com

Dwg/Stock No.	Revision
ZND508-3	1

THE COMPANY RETAIN THE RIGHT TO PERIODICALLY ALTER INFORMATION WITHIN THIS DRAWING SHEET AND WILL ATTEMPT TO NOTIFY ALL PARTIES CONCERNED OF ANY CHANGES AND THE INFORMATION ON THIS SHEET SHOULD NOT BE REPRODUCED WITHOUT THEIR WRITTEN CONSENT.

ALL DIMENSIONS IN MILLIMETRES
REMOVE ALL SHARP EDGES

THIRD ANGLE PROJECTION
DO NOT SCALE DRAWING

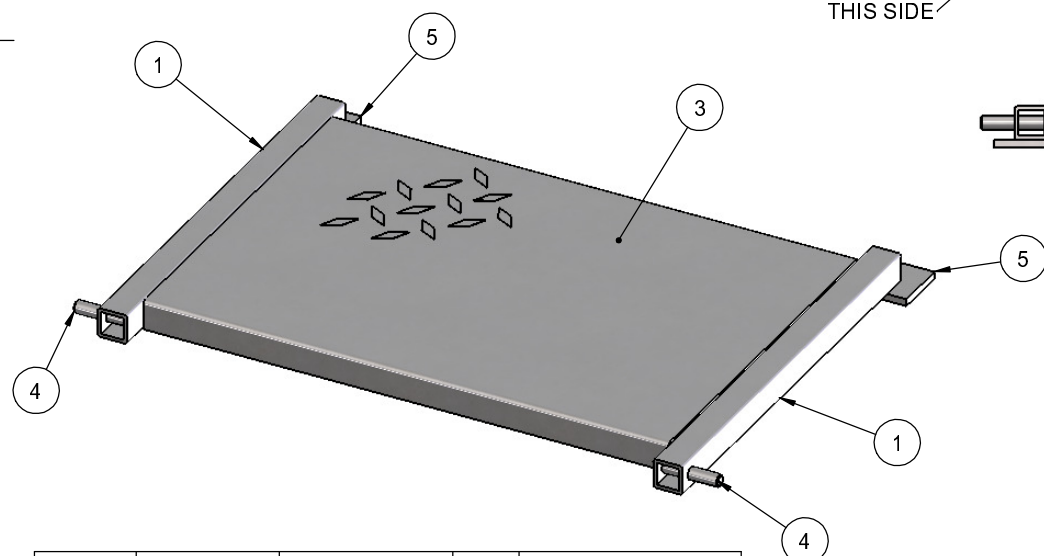
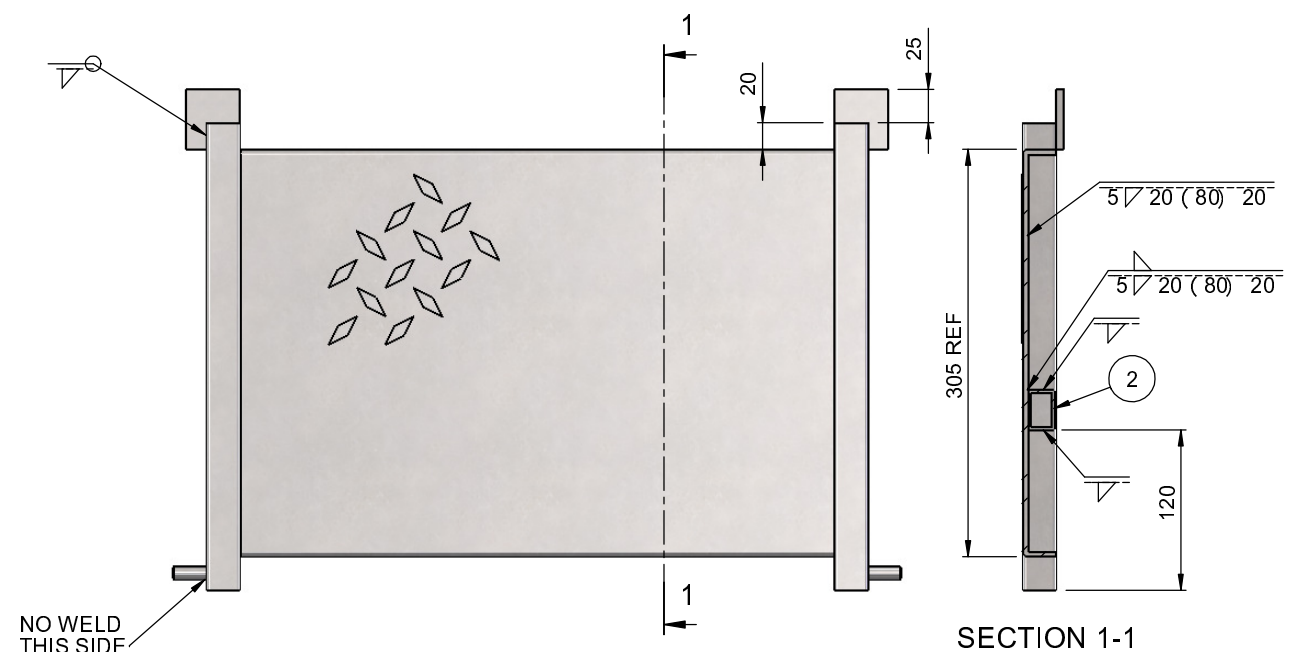

ITEM No.	PART No.	DESCRIPTION	QTY	MATERIAL SIZE
1	ZND508-4-1	STEP TUBE	2	SEE DETAIL
2	ZND508-4-2	CROSS TUBE	1	SEE DETAIL
3	ZND508-4-3	STEP PLATE	1	SEE DETAIL
4	ZND508-4-4	PIVOT PIN	2	SEE DETAIL
5	ZND508-4-5	PAD	2	40 x 6 FLAT x 45 Lg

UNLESS STATED OTHERWISE		
GENERAL TOLERANCES:		
FABRICATION	UP TO 1000mm	+/- 2mm
	1001mm & ABOVE	+/- 3mm
ANGULAR	+/- 0.5 DEGREE	
WEIGHT	+/- 10% (DUE TO MATERIAL PROPERTIES & TOLERANCES)	

TITLE: STAGE BARRIER STEP			
DRAWN	NAME	SIGNATURE	DATE
CHK'D	G. CRICK		6/12/11
FINISH:	HOT DIPPED GALVANISED		
MATERIAL:		CARBON STEEL	

REV	DATE	DESCRIPTION	DRN	CHKD	APPR
1	29/3/12	ISSUED FOR MANUFACTURE	GC		
0	17/12/11	ISSUED FOR MANUFACTURE	GC		

ZNDUK
 Mangham Road Barbot Hall Ind Estate Rotherham S61 4RJ
 Tel 01709 521100 Fax: 01709 521111 Web: www.znduk.com

Dwg/Stock No. **ZND508-4** Revision **1**

THE COMPANY RETAIN THE RIGHT TO PERIODICALLY ALTER INFORMATION WITHIN THIS DRAWING SHEET AND WILL ATTEMPT TO NOTIFY ALL PARTIES CONCERNED OF ANY CHANGES AND THE INFORMATION ON THIS SHEET SHOULD NOT BE REPRODUCED WITHOUT THEIR WRITTEN CONSENT.

ALL DIMENSIONS IN MILLIMETRES
REMOVE ALL SHARP EDGES

THIRD ANGLE PROJECTION
DO NOT SCALE DRAWING

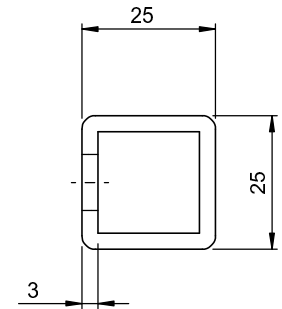
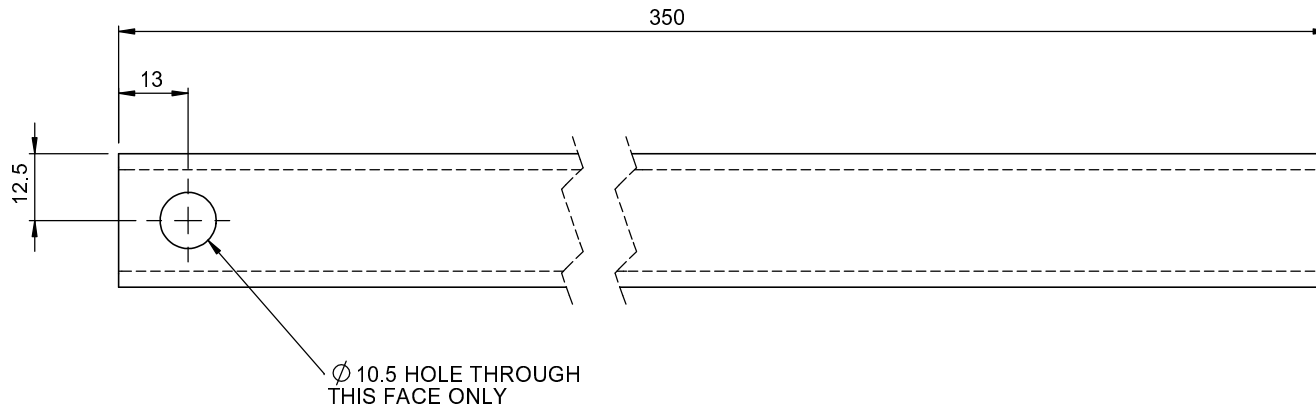

1	29/3/12	ISSUED FOR MANUFACTURE	GC		
0	17/12/11	ISSUED FOR MANUFACTURE	GC		
REV	DATE	DESCRIPTION	DRN	CHKD	APPR

TITLE: **STEP TUBE**

UNLESS STATED OTHERWISE		
GENERAL TOLERANCES:		
FABRICATION	UP TO 1000mm	+/- 2mm
	1001mm & ABOVE	+/- 3mm
ANGULAR	+/- 0.5 DEGREE	
WEIGHT	+/- 10% (DUE TO MATERIAL PROPERTIES & TOLERANCES)	

NAME	SIGNATURE	DATE
G. CRICK		6/12/11
CHK'D		
FINISH:		
NONE		

MATERIAL: **CARBON STEEL**

ZNDUK
Mangham Road Barbot Hall Ind Estate Rotherham S61 4RJ
Tel 01709 521100 Fax: 01709 521111 Web: www.znduk.com

Dwg/Stock No.	Revision
ZND508-4-1	1

THE COMPANY RETAIN THE RIGHT TO PERIODICALLY ALTER INFORMATION WITHIN THIS DRAWING SHEET AND WILL ATTEMPT TO NOTIFY ALL PARTIES CONCERNED OF ANY CHANGES AND THE INFORMATION ON THIS SHEET SHOULD NOT BE REPRODUCED WITHOUT THEIR WRITTEN CONSENT.

ALL DIMENSIONS IN MILLIMETRES
REMOVE ALL SHARP EDGES

THIRD ANGLE PROJECTION
DO NOT SCALE DRAWING

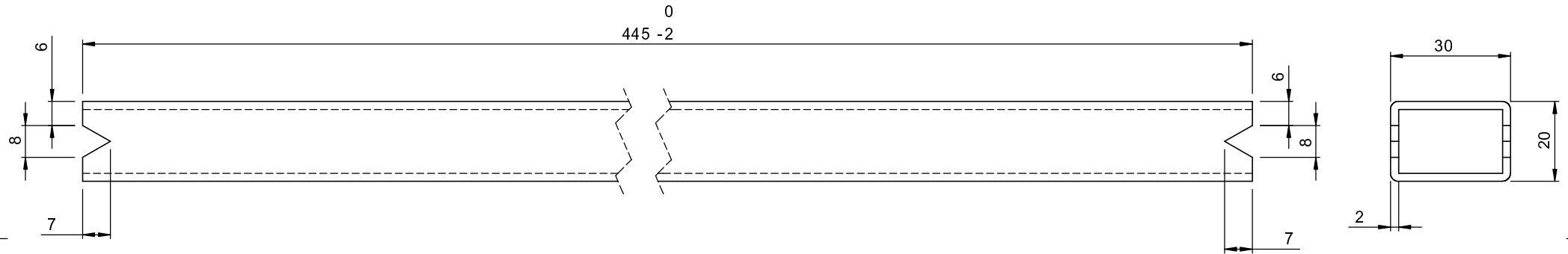

1	29/3/12	ISSUED FOR MANUFACTURE	GC		
0	17/12/11	ISSUED FOR MANUFACTURE	GC		
REV	DATE	DESCRIPTION	DRN	CHKD	APPR

TITLE: **CROSS TUBE**

UNLESS STATED OTHERWISE		
GENERAL TOLERANCES:		
FABRICATION	UP TO 1000mm	+/- 2mm
	1001mm & ABOVE	+/- 3mm
ANGULAR	+/- 0.5 DEGREE	
WEIGHT	+/- 10% (DUE TO MATERIAL PROPERTIES & TOLERANCES)	

NAME	SIGNATURE	DATE
G. CRICK		6/12/11
CHK'D		
FINISH:		
NONE		

MATERIAL:
CARBON STEEL

ZNDUK
Mangham Road Barbot Hall Ind Estate Rotherham S61 4RJ
Tel 01709 521100 Fax: 01709 521111 Web: www.znduk.com

Dwg/Stock No.	Revision
ZND508-4-2	1

THE COMPANY RETAIN THE RIGHT TO PERIODICALLY ALTER INFORMATION WITHIN THIS DRAWING SHEET AND WILL ATTEMPT TO NOTIFY ALL PARTIES CONCERNED OF ANY CHANGES AND THE INFORMATION ON THIS SHEET SHOULD NOT BE REPRODUCED WITHOUT THEIR WRITTEN CONSENT.

ALL DIMENSIONS IN MILLIMETRES
REMOVE ALL SHARP EDGES

THIRD ANGLE PROJECTION
DO NOT SCALE DRAWING

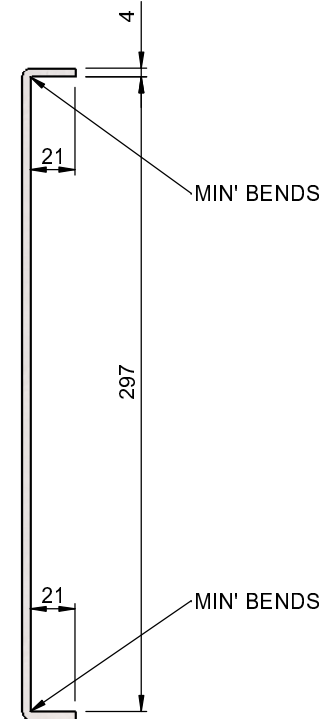
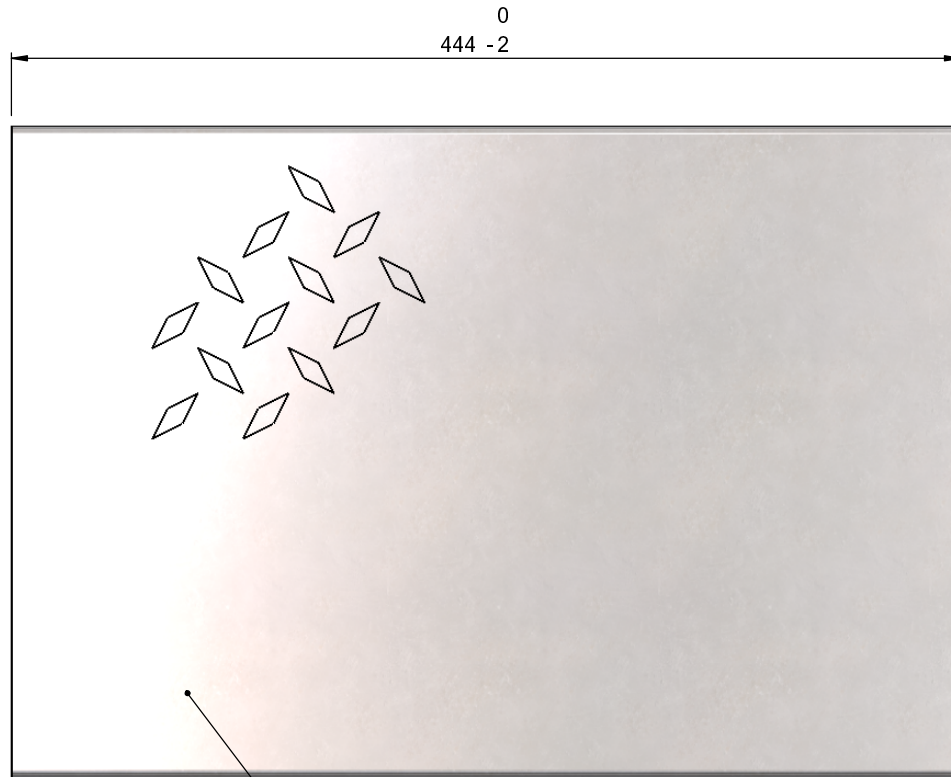

4mm THICK DURBAR PLATE
OR EQUIVALENT

1	29/3/12	ISSUED FOR MANUFACTURE	GC		
0	17/12/11	ISSUED FOR MANUFACTURE	GC		
REV	DATE	DESCRIPTION	DRN	CHKD	APPR

TITLE: **STEP PLATE**

UNLESS STATED OTHERWISE		
GENERAL TOLERANCES:		
FABRICATION	UP TO 1000mm	+/- 2mm
	1001mm & ABOVE	+/- 3mm
ANGULAR	+/- 0.5 DEGREE	
WEIGHT	+/- 10% (DUE TO MATERIAL PROPERTIES & TOLERANCES)	

DRAWN	NAME	SIGNATURE	DATE
CHK'D	G. CRICK		6/12/11
FINISH:	NONE		

MATERIAL:
CARBON STEEL

ZNDUK
Mangham Road Barbot Hall Ind Estate Rotherham S61 4RJ
Tel 01709 521100 Fax: 01709 521111 Web: www.znduk.com

Dwg/Stock No. **ZND508-4-3** Revision **1**

THE COMPANY RETAIN THE RIGHT TO PERIODICALLY ALTER INFORMATION WITHIN THIS DRAWING SHEET AND WILL ATTEMPT TO NOTIFY ALL PARTIES CONCERNED OF ANY CHANGES AND THE INFORMATION ON THIS SHEET SHOULD NOT BE REPRODUCED WITHOUT THEIR WRITTEN CONSENT.

1
2
3
4
5
6
7
8

ALL DIMENSIONS IN MILLIMETRES
REMOVE ALL SHARP EDGES

THIRD ANGLE PROJECTION
DO NOT SCALE DRAWING

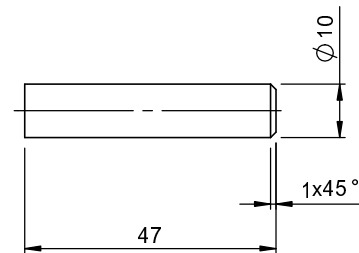

1	29/3/12	ISSUED FOR MANUFACTURE	GC	.	.
0	17/12/11	ISSUED FOR MANUFACTURE	GC	.	.
REV	DATE	DESCRIPTION	DRN	CHKD	APPR

TITLE:
PIVOT PIN

UNLESS STATED OTHERWISE		
GENERAL TOLERANCES:		
FABRICATION	UP TO 1000mm	+/- 2mm
	1001mm & ABOVE	+/- 3mm
ANGULAR	+/- 0.5 DEGREE	
WEIGHT	+/- 10% (DUE TO MATERIAL PROPERTIES & TOLERANCES)	

	NAME	SIGNATURE	DATE
DRAWN	G. CRICK		6/12/11
CHK'D			
FINISH:			
NONE			

MATERIAL:
CARBON STEEL

ZNDUK

Mangham Road Barbot Hall Ind Estate Rotherham S61 4RJ
Tel 01709 521100 Fax: 01709 521111 Web: www.znduk.com

Dwg/Stock No.	Revision
ZND508-4-4	1

THE COMPANY RETAIN THE RIGHT TO PERIODICALLY ALTER INFORMATION WITHIN THIS DRAWING SHEET AND WILL ATTEMPT TO NOTIFY ALL PARTIES CONCERNED OF ANY CHANGES AND THE INFORMATION ON THIS SHEET SHOULD NOT BE REPRODUCED WITHOUT THEIR WRITTEN CONSENT.