

1 2 3 4 5 6 7 8  
 ALL DIMENSIONS IN MILLIMETRES  
 REMOVE ALL SHARP EDGES

1025 8  
 THIRD ANGLE PROJECTION  
 DO NOT SCALE DRAWING

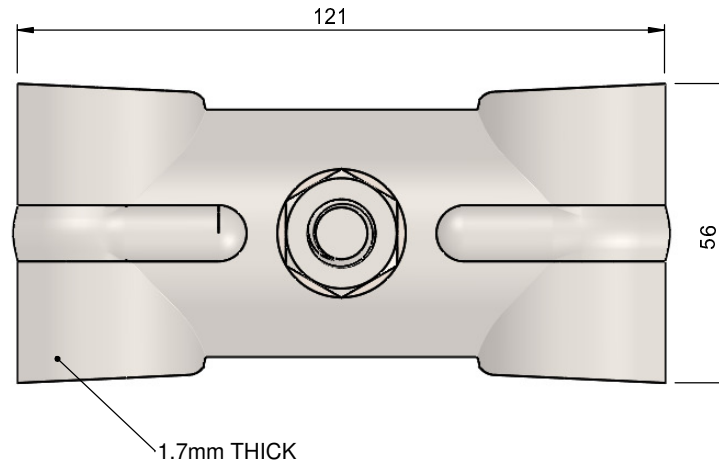
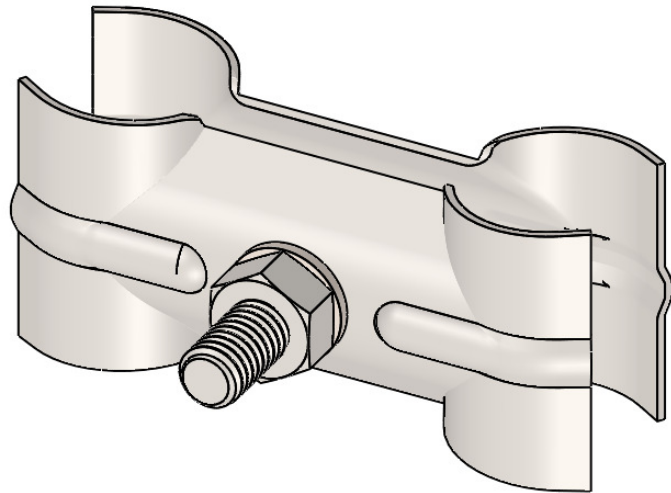
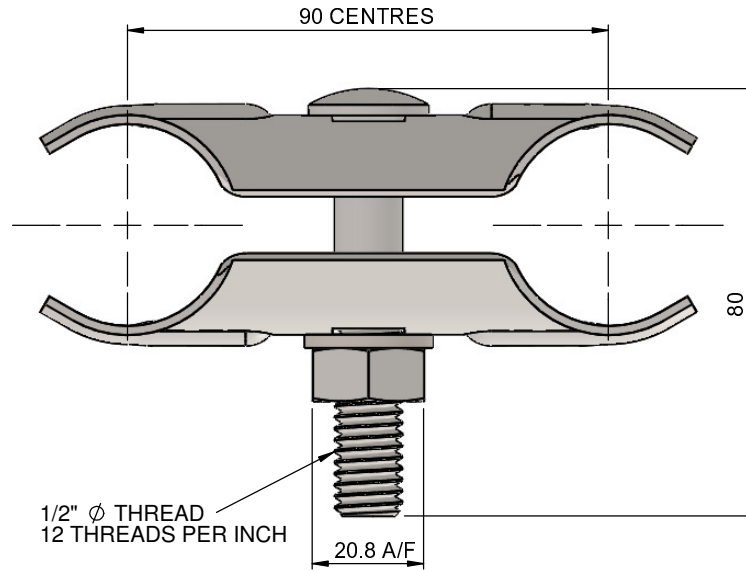

5	17/12/15	ISSUED FOR MANUFACTURE	GC		
4	10/4/14	ISSUED FOR MANUFACTURE	GC		
REV	DATE	DESCRIPTION	DRN	CHKD	APPR

TOLERANCES - UNLESS STATED OTHERWISE		
UNTOLERANCED DIMENSIONS	+/- 2mm	
CUTTING LENGTHS	+/- 2mm	
FABRICATION	UP TO 300mm	+/- 1mm
	UP TO 1000mm	+/- 2mm
	1001mm & ABOVE	+/- 3mm
	ANGULAR	+/- 1°
MACHINING	+/- 0.2mm	
GAUGE	+/- 10%	
WEIGHT	+/- 10% (DUE TO MATERIAL PROPERTIES & TOLERANCES)	

TITLE: <b>FENCE COUPLER</b>			
NAME	SIGNATURE	DATE	MATERIAL:
G. CRICK		15/11/7	CARBON STEEL PRE-GALVANISED
FINISH:	NONE		

**OUTDOOR**  
 השכרת ציוד לאירועים ולאתרי בניה ועבודה

Drw / Stockcode No. **08551030** Revision **5**

THE COMPANY RETAIN THE RIGHT TO PERIODICALLY ALTER INFORMATION WITHIN THIS DRAWING SHEET AND WILL ATTEMPT TO NOTIFY ALL PARTIES CONCERNED OF ANY CHANGES AND THE INFORMATION ON THIS SHEET SHOULD NOT BE REPRODUCED WITHOUT THEIR WRITTEN CONSENT.