

1
2
3
4
5
6
7
8

ALL DIMENSIONS IN MILLIMETRES
REMOVE ALL SHARP EDGES

THIRD ANGLE PROJECTION
DO NOT SCALE DRAWING

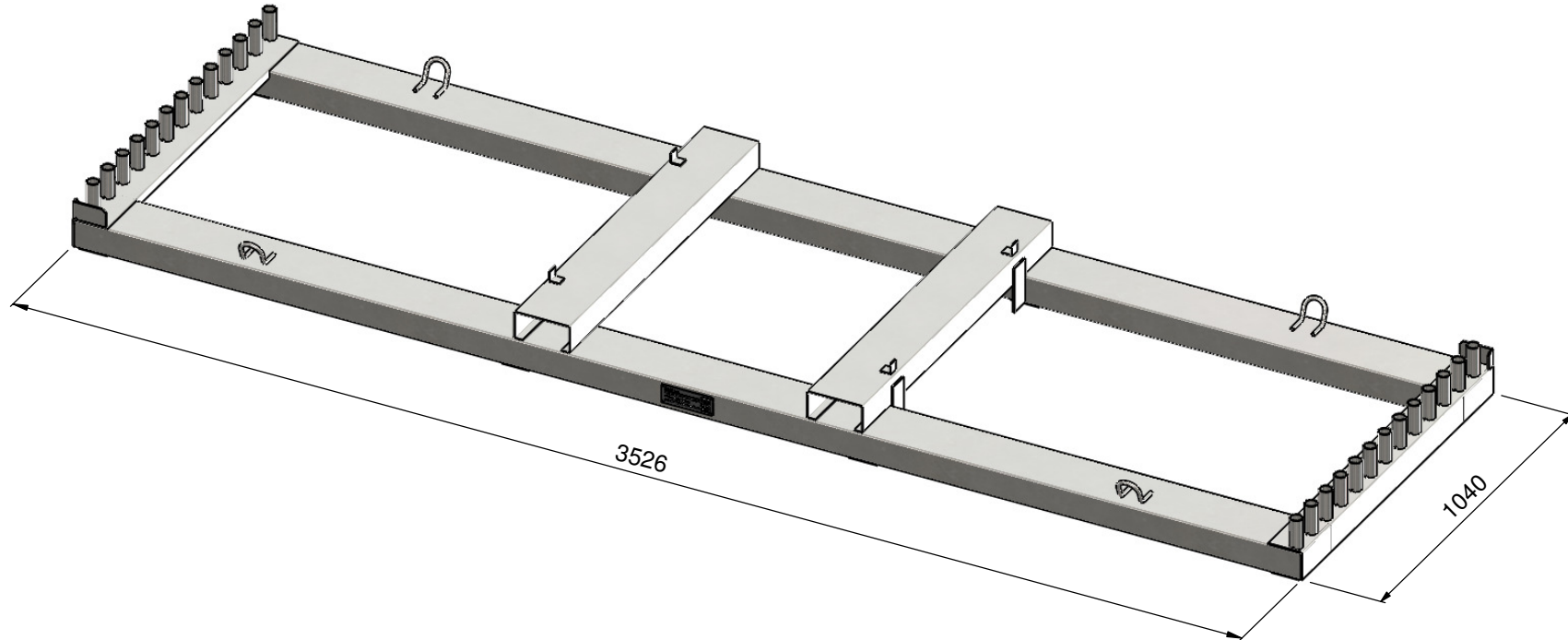

WEIGHT NOTE:
WEIGHT BEFORE GALVANISING = 85.4 Kg
WEIGHT GALVANISED = 90.5 Kg (ASSUMING 6% ADDED)

1	14/1/14	ISSUED FOR MANUFACTURE	GC		
0	19/12/13	ISSUED FOR MANUFACTURE	GC		
REV	DATE	DESCRIPTION	DRN	CHKD	APPR

TOLERANCES - UNLESS STATED OTHERWISE		TITLE:
UNTOLERANCED DIMENSIONS	+/- 2mm	TRANSPORT PALLET 26
CUTTING LENGTHS	+/- 2mm	
FABRICATION	UP TO 300mm	+/- 1mm
	UP TO 1000mm	+/- 2mm
	1001mm & ABOVE	+/- 3mm
	ANGULAR	+/- 1°
MACHINING	+/- 0.2mm	
GAUGE	+/- 10%	
WEIGHT	+/- 10% (DUE TO MATERIAL PROPERTIES & TOLERANCES)	

NAME	SIGNATURE	DATE	MATERIAL:
G. CRICK		19/12/13	CARBON STEEL
CHK'D			
FINISH:	HOT DIPPED GALVANISED		

ZNDUK_e

Drw / Stockcode No.	Revision
ZNDDE0120	1

EURO Transportpalette TP26 - 1115

THE COMPANY RETAIN THE RIGHT TO PERIODICALLY ALTER INFORMATION WITHIN THIS DRAWING SHEET AND WILL ATTEMPT TO NOTIFY ALL PARTIES CONCERNED OF ANY CHANGES AND THE INFORMATION ON THIS SHEET SHOULD NOT BE REPRODUCED WITHOUT THEIR WRITTEN CONSENT.

ALL DIMENSIONS IN MILLIMETRES
REMOVE ALL SHARP EDGES

THIRD ANGLE PROJECTION
DO NOT SCALE DRAWING

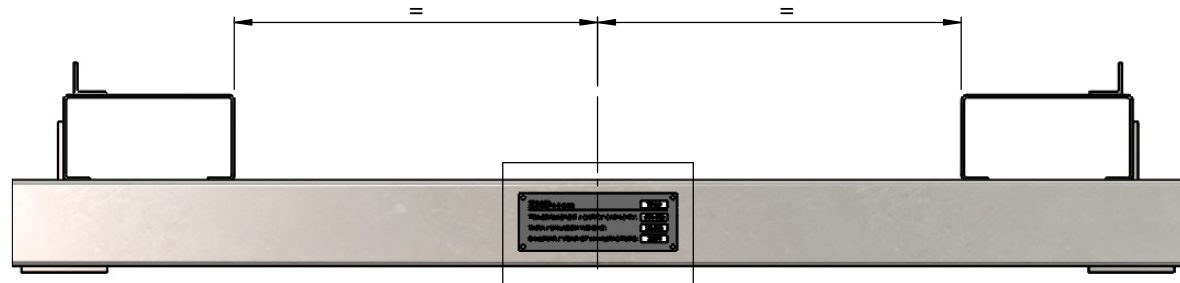

12

LABEL - ZNDDE0120-10



DRILL THROUGH HOLE
IN EACH CORNER AND
FIX LABEL TO STILLAGE
WITH 4 x RIVET

1	14/1/14	ISSUED FOR MANUFACTURE	GC	.	.
0	19/12/13	ISSUED FOR MANUFACTURE	GC	.	.
REV	DATE	DESCRIPTION	DRN	CHKD	APPR

TOLERANCES - UNLESS STATED OTHERWISE		TITLE:
UNTOLERANCED DIMENSIONS	+/- 2mm	TRANSPORT PALLET 26
CUTTING LENGTHS	+/- 2mm	
FABRICATION	UP TO 300mm	+/- 1mm
	UP TO 1000mm	+/- 2mm
	1001mm & ABOVE	+/- 3mm
	ANGULAR	+/- 1°
MACHINING	+/- 0.2mm	
GAUGE	+/- 10%	
WEIGHT	+/- 10% (DUE TO MATERIAL PROPERTIES & TOLERANCES)	

NAME	SIGNATURE	DATE	MATERIAL:
G. CRICK		19/12/13	CARBON STEEL
CHK'D			
FINISH:			
HOT DIPPED GALVANISED			



Drw / Stockcode No. **ZNDDE0120 - GA** Revision **1**

EURO Transportpalette TP26 - 1115

THE COMPANY RETAIN THE RIGHT TO PERIODICALLY ALTER INFORMATION WITHIN THIS DRAWING SHEET AND WILL ATTEMPT TO NOTIFY ALL PARTIES CONCERNED OF ANY CHANGES AND THE INFORMATION ON THIS SHEET SHOULD NOT BE REPRODUCED WITHOUT THEIR WRITTEN CONSENT.

1
2
3
4
5
6
7
8

ALL DIMENSIONS IN MILLIMETRES
REMOVE ALL SHARP EDGES

THIRD ANGLE PROJECTION
DO NOT SCALE DRAWING

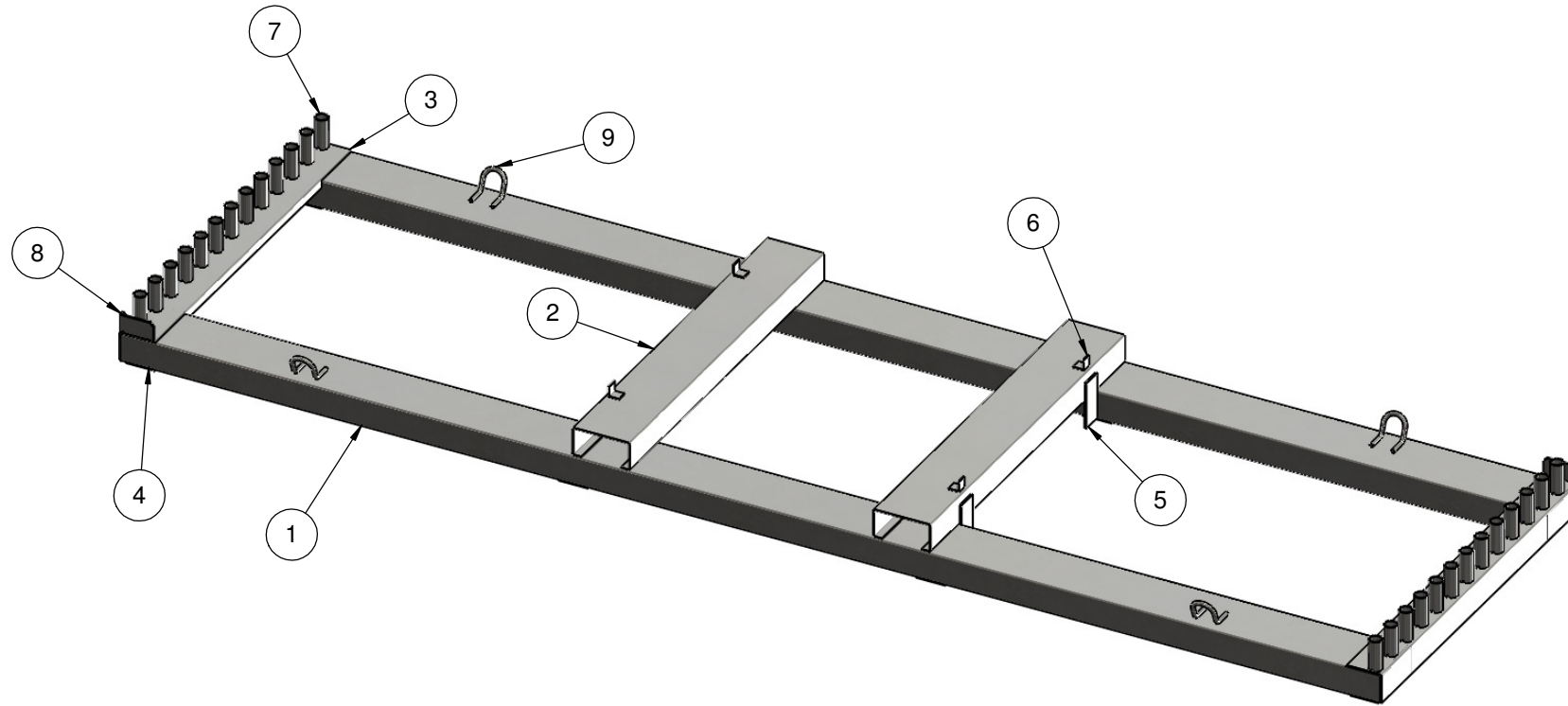

ITEM No.	PART No.	DESCRIPTION	QTY	MATERIAL SIZE	SEE DETAIL
1	ZNDDE0120-1	LONG CHANNEL	2		SEE DETAIL
2	ZNDDE0120-2	CROSS CHANNEL	2		SEE DETAIL
3	ZNDDE0120-3	END CHANNEL	2		SEE DETAIL
4	ZNDDE0120-4	BASE PLATE	8	80 x 6 FLAT x 145 Lg	
5	ZNDDE0120-5	STIFFENING PLATE	4	60 x 5 FLAT x 130 Lg	
6	ZNDDE0120-6	GUIDE ANGLE	4	30 x 30 x 3 RSA x 30 Lg	
7	ZNDDE0120-7	SPIGOT	26		SEE DETAIL
8	ZNDDE0120-8	PANEL GUIDE	2		SEE DETAIL
9	ZNDDE0120-9	STRAP HOOK	4		SEE DETAIL

WEIGHT NOTE:
WEIGHT BEFORE GALVANISING = 85.4 Kg
WEIGHT GALVANISED = 90.5 Kg (ASSUMING 6% ADDED)

REV	DATE	DESCRIPTION	DRN	CHKD	APPR
1	14/1/14	ISSUED FOR MANUFACTURE	GC		
0	19/12/13	ISSUED FOR MANUFACTURE	GC		

TOLERANCES - UNLESS STATED OTHERWISE	
UNTOLERANCED DIMENSIONS	+/- 2mm
CUTTING LENGTHS	+/- 2mm
FABRICATION	
UP TO 300mm	+/- 1mm
UP TO 1000mm	+/- 2mm
1001mm & ABOVE	+/- 3mm
ANGULAR	+/- 1°
MACHINING	+/- 0.2mm
GAUGE	+/- 10%
WEIGHT	+/- 10% (DUE TO MATERIAL PROPERTIES & TOLERANCES)

TITLE: TRANSPORT PALLET 26 FAB SHT 1			
NAME	SIGNATURE	DATE	MATERIAL:
G. CRICK		20/11/13	CARBON STEEL
FINISH:	HOT DIPPED GALVANISED		

ZNDUK

EURO Transportpalette TP26 - 1115

THE COMPANY RETAIN THE RIGHT TO PERIODICALLY ALTER INFORMATION WITHIN THIS DRAWING SHEET AND WILL ATTEMPT TO NOTIFY ALL PARTIES CONCERNED OF ANY CHANGES AND THE INFORMATION ON THIS SHEET SHOULD NOT BE REPRODUCED WITHOUT THEIR WRITTEN CONSENT.

Drw / Stockcode No.

ZNDDE0120 - FAB SHT 1

Revision

1

WEIGHT: SEE NOTE

SCALE: 1:12.5

SHEET 3 OF 13

A3

ALL DIMENSIONS IN MILLIMETRES
REMOVE ALL SHARP EDGES

THIRD ANGLE PROJECTION
DO NOT SCALE DRAWING

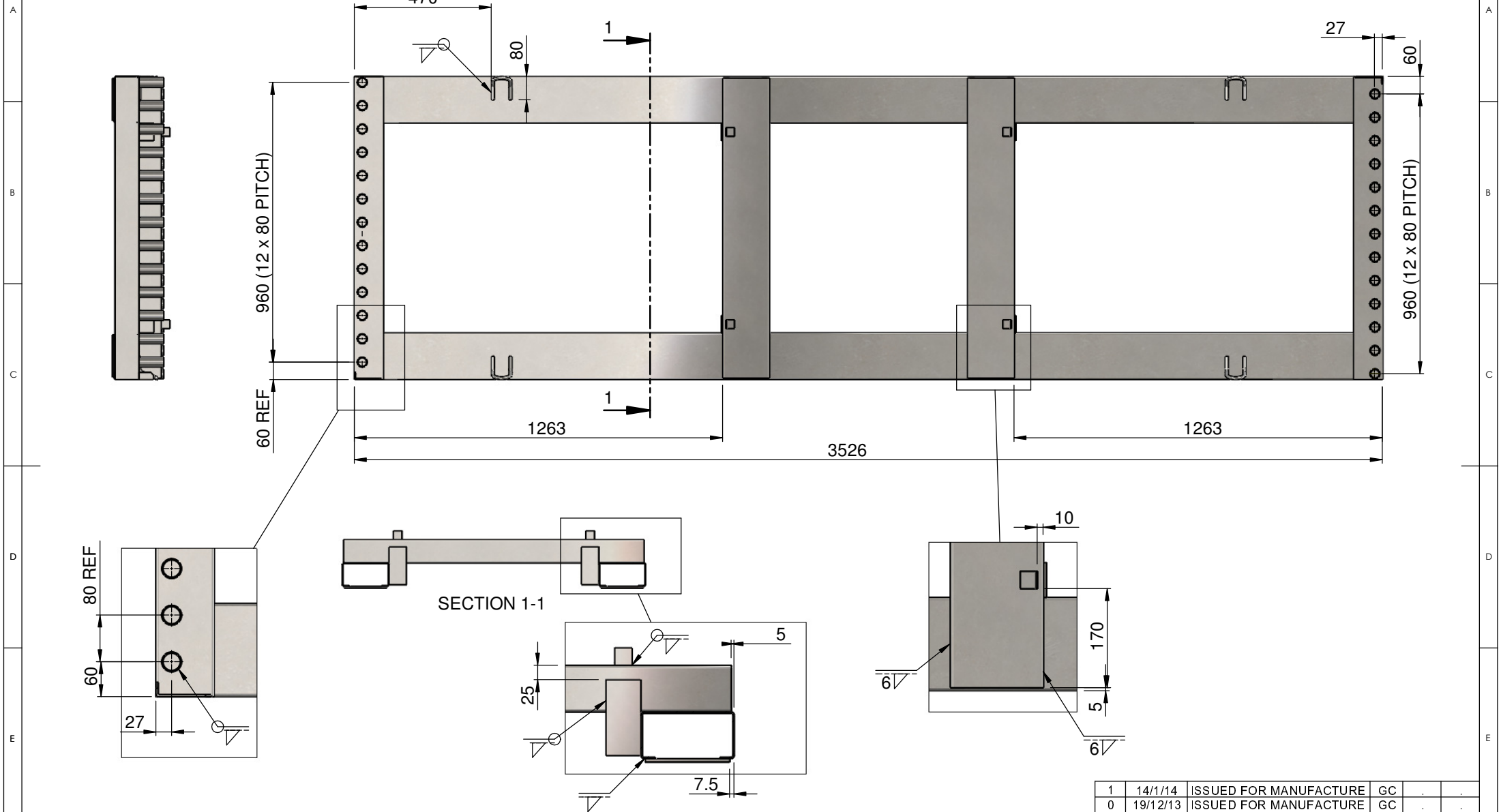

REV	DATE	DESCRIPTION	DRN	CHKD	APPR
1	14/1/14	ISSUED FOR MANUFACTURE	GC		
0	19/12/13	ISSUED FOR MANUFACTURE	GC		

WEIGHT NOTE:
 WEIGHT BEFORE GALVANISING = 85.4 Kg
 WEIGHT GALVANISED = 90.5 Kg (ASSUMING 6% ADDED)

TOLERANCES - UNLESS STATED OTHERWISE	
UNTOLERANCED DIMENSIONS	+/- 2mm
CUTTING LENGTHS	+/- 2mm
FABRICATION	
UP TO 300mm	+/- 1mm
UP TO 1000mm	+/- 2mm
1001mm & ABOVE	+/- 3mm
ANGULAR	+/- 1°
MACHINING	+/- 0.2mm
GAUGE	+/- 10%
WEIGHT	+/- 10% (DUE TO MATERIAL PROPERTIES & TOLERANCES)

TITLE: TRANSPORT PALLET FAB SHT 2				MATERIAL:	
NAME	SIGNATURE	DATE	CARBON STEEL		
DRAWN	G. CRICK	19/12/13	HOT DIPPED GALVANISED		
CHK'D			WEIGHT: SEE NOTE		

ZNDUK
 Drw / Stockcode No. ZNDDE0120 - FAB SHT 2
 Revision 1
 SCALE: 1:12.5
 SHEET 4 OF 13

EURO Transportpalette TP26 - 1115

THE COMPANY RETAIN THE RIGHT TO PERIODICALLY ALTER INFORMATION WITHIN THIS DRAWING SHEET AND WILL ATTEMPT TO NOTIFY ALL PARTIES CONCERNED OF ANY CHANGES AND THE INFORMATION ON THIS SHEET SHOULD NOT BE REPRODUCED WITHOUT THEIR WRITTEN CONSENT.

ALL DIMENSIONS IN MILLIMETRES
REMOVE ALL SHARP EDGES

THIRD ANGLE PROJECTION
DO NOT SCALE DRAWING

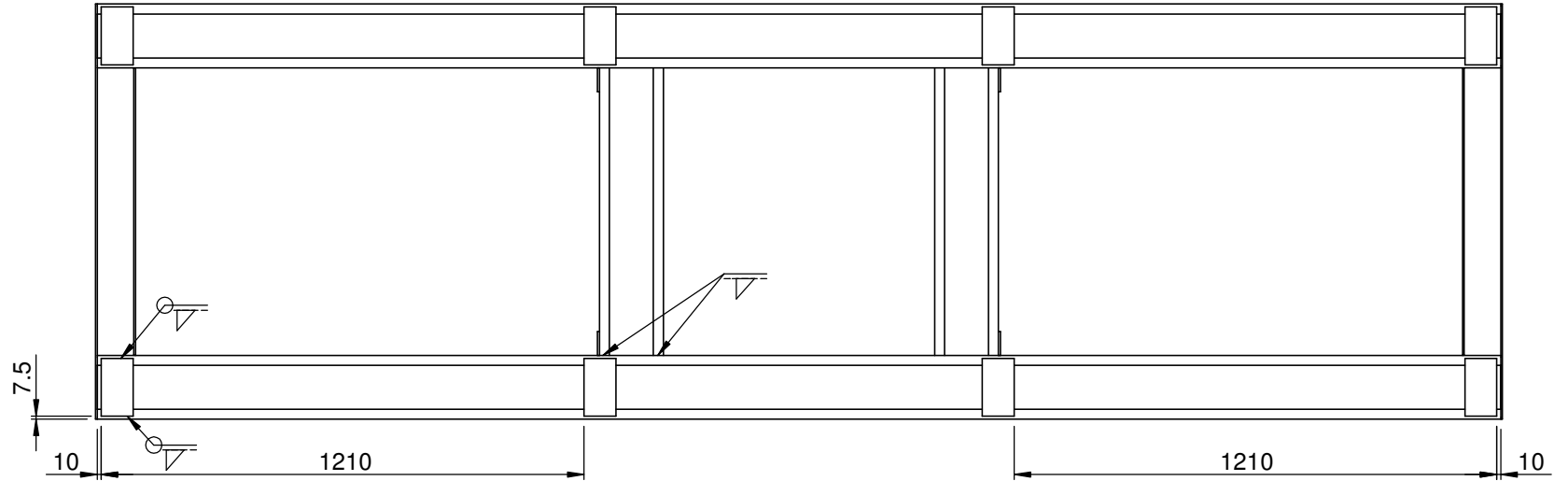

VIEW ON UNDERSIDE

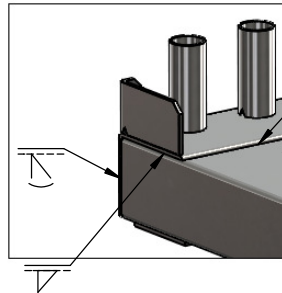

NOTE:
POSITION OF NOTCH
IN SPIGOTS

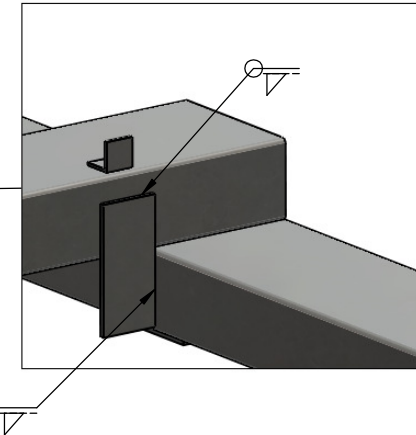
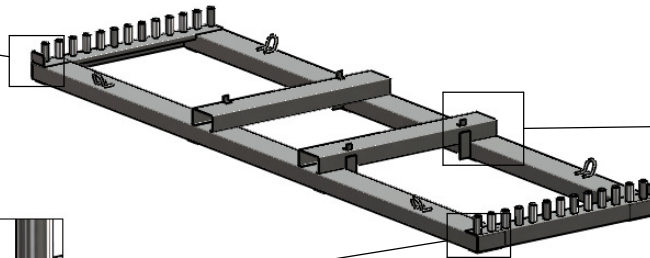
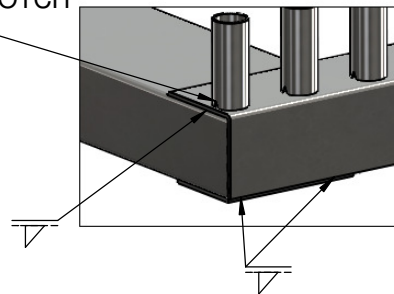

1	14/1/14	ISSUED FOR MANUFACTURE	GC		
0	19/12/13	ISSUED FOR MANUFACTURE	GC		
REV	DATE	DESCRIPTION	DRN	CHKD	APPR

WEIGHT NOTE:
WEIGHT BEFORE GALVANISING = 85.4 Kg
WEIGHT GALVANISED = 90.5 Kg (ASSUMING 6% ADDED)

TOLERANCES - UNLESS STATED OTHERWISE		
UNTOLERANCED DIMENSIONS	+/- 2mm	
CUTTING LENGTHS	+/- 2mm	
FABRICATION	UP TO 300mm	+/- 1mm
	UP TO 1000mm	+/- 2mm
	1001mm & ABOVE	+/- 3mm
	ANGULAR	+/- 1°
MACHINING	+/- 0.2mm	
GAUGE	+/- 10%	
WEIGHT	+/- 10% (DUE TO MATERIAL PROPERTIES & TOLERANCES)	

TITLE: **TRANSPORT PALLET 26
FAB SHT 3**

NAME	SIGNATURE	DATE
G. CRICK		19/12/13
CHK'D		

FINISH: **HOT DIPPED
GALVANISED**

MATERIAL:
CARBON STEEL

ZNDUK

Drw / Stockcode No.

ZNDDE0120 - FAB SHT 3

Revision

1

EURO **Transportpalette TP26 - 1115**

THE COMPANY RETAIN THE RIGHT TO PERIODICALLY ALTER INFORMATION WITHIN THIS DRAWING SHEET AND WILL ATTEMPT TO NOTIFY ALL PARTIES CONCERNED OF ANY CHANGES AND THE INFORMATION ON THIS SHEET SHOULD NOT BE REPRODUCED WITHOUT THEIR WRITTEN CONSENT.

WEIGHT: SEE NOTE

SCALE: 1:12.5

SHEET 5 OF 13

A3

ALL DIMENSIONS IN MILLIMETRES
REMOVE ALL SHARP EDGES

THIRD ANGLE PROJECTION
DO NOT SCALE DRAWING

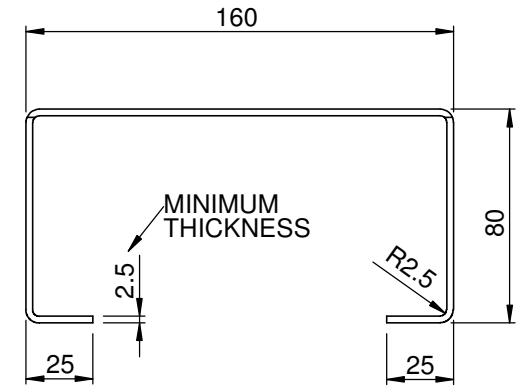
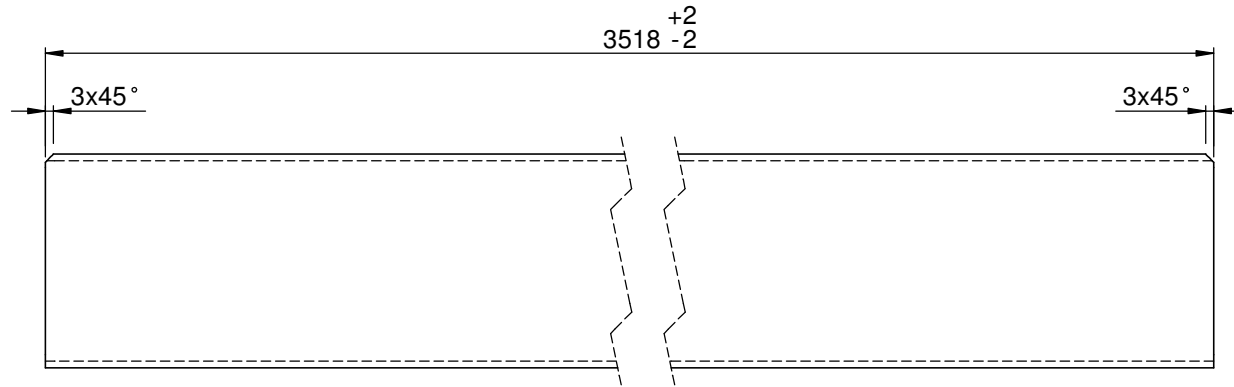

1	14/1/14	ISSUED FOR MANUFACTURE	GC		
0	19/12/13	ISSUED FOR MANUFACTURE	GC		
REV	DATE	DESCRIPTION	DRN	CHKD	APPR

TOLERANCES - UNLESS STATED OTHERWISE		
UNTOLERANCED DIMENSIONS	+/- 2mm	
CUTTING LENGTHS	+/- 2mm	
FABRICATION	UP TO 300mm	+/- 1mm
	UP TO 1000mm	+/- 2mm
	1001mm & ABOVE	+/- 3mm
	ANGULAR	+/- 1°
MACHINING	+/- 0.2mm	
GAUGE	+/- 10%	
WEIGHT	+/- 10% (DUE TO MATERIAL PROPERTIES & TOLERANCES)	

TITLE: LONG CHANNEL			
NAME	SIGNATURE	DATE	MATERIAL:
G. CRICK		19/12/13	CARBON STEEL
FINISH:	NONE		



Drw / Stockcode No.	Revision
ZNDDE0120-1	1

THE COMPANY RETAIN THE RIGHT TO PERIODICALLY ALTER INFORMATION WITHIN THIS DRAWING SHEET AND WILL ATTEMPT TO NOTIFY ALL PARTIES CONCERNED OF ANY CHANGES AND THE INFORMATION ON THIS SHEET SHOULD NOT BE REPRODUCED WITHOUT THEIR WRITTEN CONSENT.

ALL DIMENSIONS IN MILLIMETRES
REMOVE ALL SHARP EDGES

THIRD ANGLE PROJECTION
DO NOT SCALE DRAWING

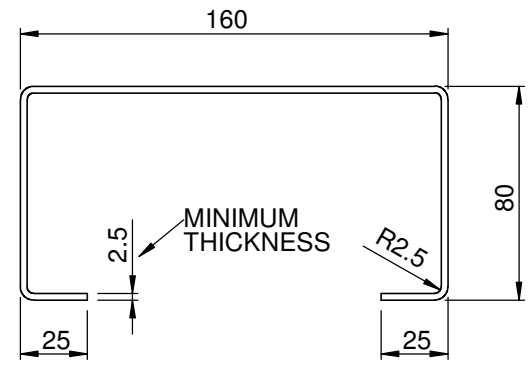
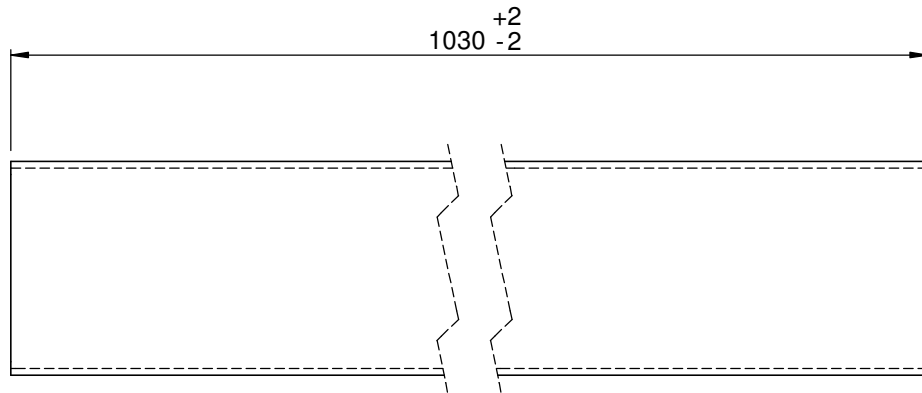

1	14/1/14	ISSUED FOR MANUFACTURE	GC		
0	19/12/13	ISSUED FOR MANUFACTURE	GC		
REV	DATE	DESCRIPTION	DRN	CHKD	APPR

TOLERANCES - UNLESS STATED OTHERWISE		
UNTOLERANCED DIMENSIONS	+/- 2mm	
CUTTING LENGTHS	+/- 2mm	
FABRICATION	UP TO 300mm	+/- 1mm
	UP TO 1000mm	+/- 2mm
	1001mm & ABOVE	+/- 3mm
	ANGULAR	+/- 1°
MACHINING	+/- 0.2mm	
GAUGE	+/- 10%	
WEIGHT	+/- 10% (DUE TO MATERIAL PROPERTIES & TOLERANCES)	

TITLE: CROSS CHANNEL			
NAME	SIGNATURE	DATE	MATERIAL:
G. CRICK		19/12/13	CARBON STEEL
FINISH:		NONE	

ZNDUK_e

Drw / Stockcode No. **ZNDDE0120-2** Revision **1**

THE COMPANY RETAIN THE RIGHT TO PERIODICALLY ALTER INFORMATION WITHIN THIS DRAWING SHEET AND WILL ATTEMPT TO NOTIFY ALL PARTIES CONCERNED OF ANY CHANGES AND THE INFORMATION ON THIS SHEET SHOULD NOT BE REPRODUCED WITHOUT THEIR WRITTEN CONSENT.

ALL DIMENSIONS IN MILLIMETRES
REMOVE ALL SHARP EDGES

THIRD ANGLE PROJECTION
DO NOT SCALE DRAWING

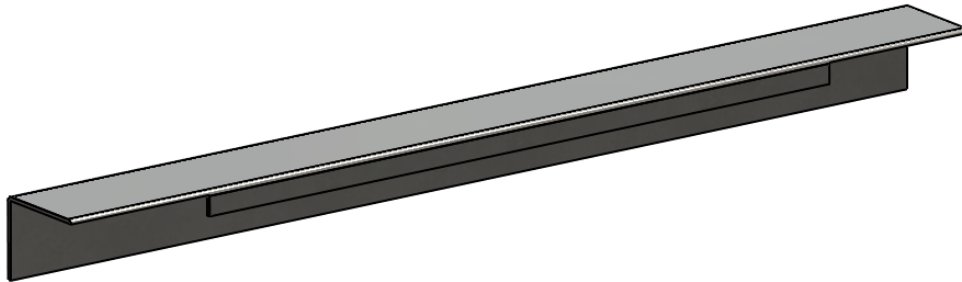
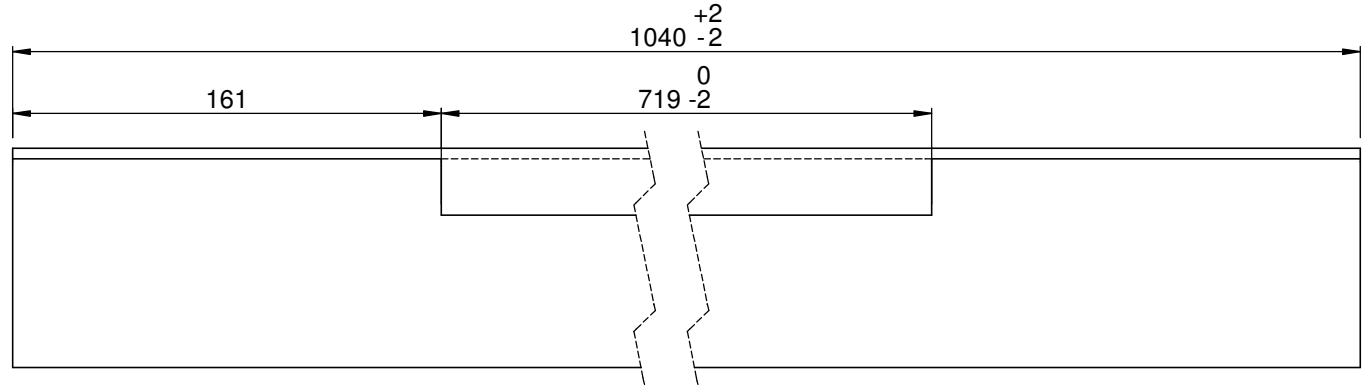
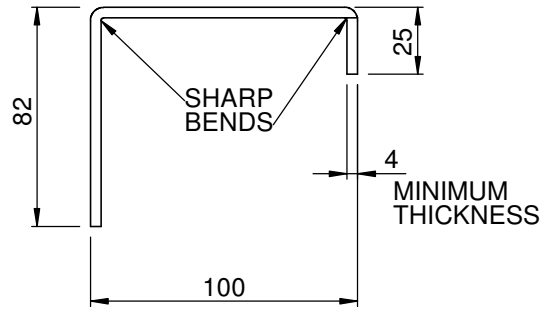

1	14/1/14	ISSUED FOR MANUFACTURE	GC		
0	19/12/13	ISSUED FOR MANUFACTURE	GC		
REV	DATE	DESCRIPTION	DRN	CHKD	APPR

TOLERANCES - UNLESS STATED OTHERWISE	
UNTOLERANCED DIMENSIONS	+/- 2mm
CUTTING LENGTHS	+/- 2mm
FABRICATION	
UP TO 300mm	+/- 1mm
UP TO 1000mm	+/- 2mm
1001mm & ABOVE	+/- 3mm
ANGULAR	+/- 1°
MACHINING	+/- 0.2mm
GAUGE	+/- 10%
WEIGHT	+/- 10% (DUE TO MATERIAL PROPERTIES & TOLERANCES)

TITLE: END CHANNEL			
NAME	SIGNATURE	DATE	MATERIAL:
G. CRICK		19/12/13	CARBON STEEL
FINISH:	NONE		

ZNDUK_e

Drw / Stockcode No.	Revision
ZNDDE0120-3	1

THE COMPANY RETAIN THE RIGHT TO PERIODICALLY ALTER INFORMATION WITHIN THIS DRAWING SHEET AND WILL ATTEMPT TO NOTIFY ALL PARTIES CONCERNED OF ANY CHANGES AND THE INFORMATION ON THIS SHEET SHOULD NOT BE REPRODUCED WITHOUT THEIR WRITTEN CONSENT.

ALL DIMENSIONS IN MILLIMETRES
REMOVE ALL SHARP EDGES

THIRD ANGLE PROJECTION
DO NOT SCALE DRAWING

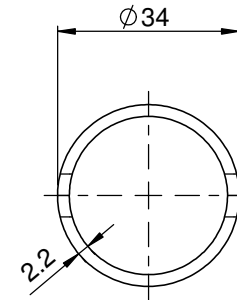
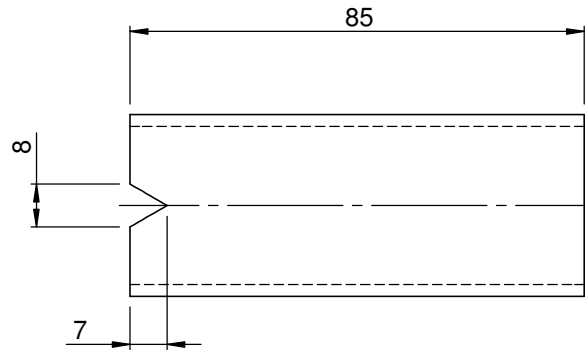

1	14/1/14	ISSUED FOR MANUFACTURE	GC	.	.
0	19/12/13	ISSUED FOR MANUFACTURE	GC	.	.
REV	DATE	DESCRIPTION	DRN	CHKD	APPR

TOLERANCES - UNLESS STATED OTHERWISE		TITLE:
UNTOLERANCED DIMENSIONS	+/- 2mm	TUBE SPIGOT
CUTTING LENGTHS	+/- 2mm	
FABRICATION	UP TO 300mm	+/- 1mm
	UP TO 1000mm	+/- 2mm
	1001mm & ABOVE	+/- 3mm
	ANGULAR	+/- 1°
MACHINING	+/- 0.2mm	
GAUGE	+/- 10%	
WEIGHT	+/- 10% (DUE TO MATERIAL PROPERTIES & TOLERANCES)	

NAME	SIGNATURE	DATE	MATERIAL:
G. CRICK		19/12/13	CARBON STEEL
CHK'D			
FINISH:			NONE

ZNDUK _e	
Drw / Stockcode No.	Revision
ZNDDE0120-7	1

THE COMPANY RETAIN THE RIGHT TO PERIODICALLY ALTER INFORMATION WITHIN THIS DRAWING SHEET AND WILL ATTEMPT TO NOTIFY ALL PARTIES CONCERNED OF ANY CHANGES AND THE INFORMATION ON THIS SHEET SHOULD NOT BE REPRODUCED WITHOUT THEIR WRITTEN CONSENT.

ALL DIMENSIONS IN MILLIMETRES
REMOVE ALL SHARP EDGES

THIRD ANGLE PROJECTION
DO NOT SCALE DRAWING

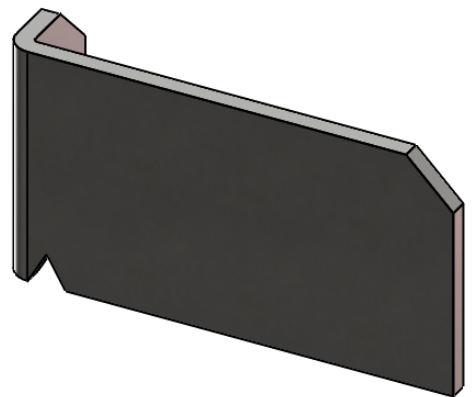
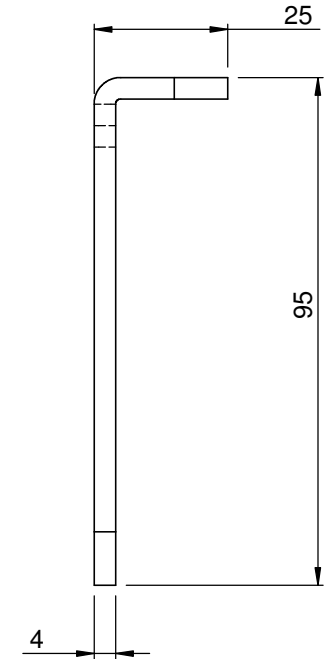
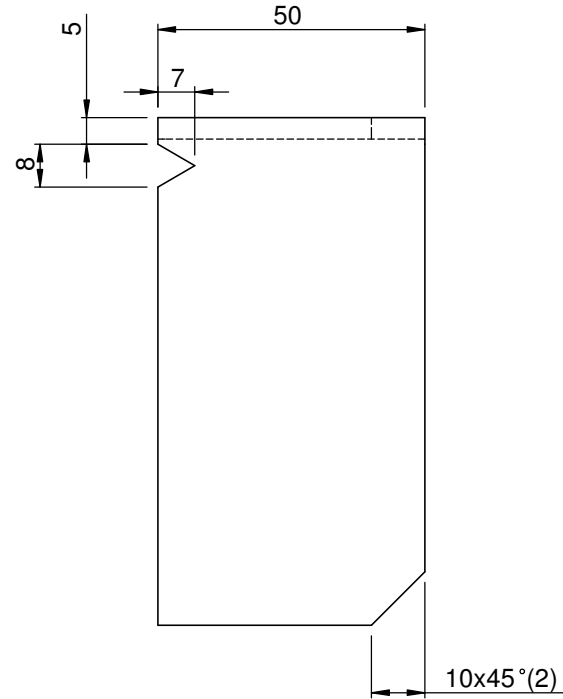

1	14/1/14	ISSUED FOR MANUFACTURE	GC		
0	19/12/13	ISSUED FOR MANUFACTURE	GC		
REV	DATE	DESCRIPTION	DRN	CHKD	APPR

TOLERANCES - UNLESS STATED OTHERWISE	
UNTOLERANCED DIMENSIONS	+/- 2mm
CUTTING LENGTHS	+/- 2mm
FABRICATION	
UP TO 300mm	+/- 1mm
UP TO 1000mm	+/- 2mm
1001mm & ABOVE	+/- 3mm
ANGULAR	+/- 1°
MACHINING	+/- 0.2mm
GAUGE	+/- 10%
WEIGHT	+/- 10% (DUE TO MATERIAL PROPERTIES & TOLERANCES)

TITLE: PANEL GUIDE			
NAME	SIGNATURE	DATE	MATERIAL:
G. CRICK		19/12/13	CARBON STEEL
FINISH:	NONE		

ZNDUK_e

Drw / Stockcode No. **ZNDDE0120-8** Revision **1**

THE COMPANY RETAIN THE RIGHT TO PERIODICALLY ALTER INFORMATION WITHIN THIS DRAWING SHEET AND WILL ATTEMPT TO NOTIFY ALL PARTIES CONCERNED OF ANY CHANGES AND THE INFORMATION ON THIS SHEET SHOULD NOT BE REPRODUCED WITHOUT THEIR WRITTEN CONSENT.

ALL DIMENSIONS IN MILLIMETRES
REMOVE ALL SHARP EDGES

THIRD ANGLE PROJECTION
DO NOT SCALE DRAWING

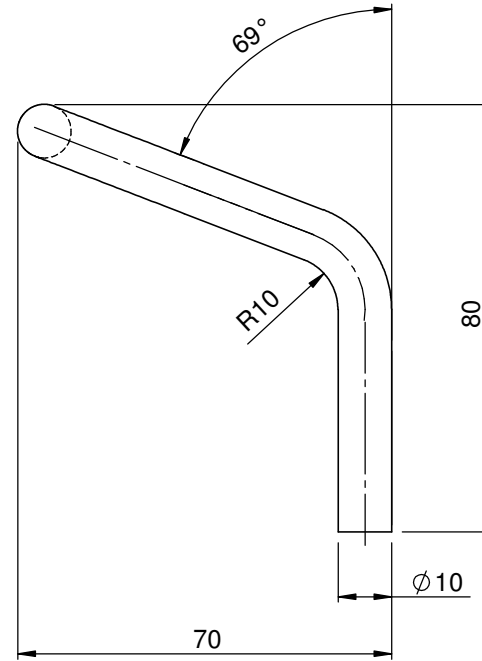
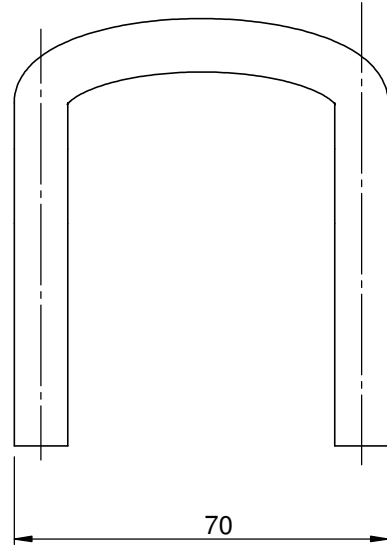

1	14/1/14	ISSUED FOR MANUFACTURE	GC		
0	19/12/13	ISSUED FOR MANUFACTURE	GC		
REV	DATE	DESCRIPTION	DRN	CHKD	APPR

TOLERANCES - UNLESS STATED OTHERWISE		
UNTOLERANCED DIMENSIONS	+/- 2mm	
CUTTING LENGTHS	+/- 2mm	
FABRICATION	UP TO 300mm	+/- 1mm
	UP TO 1000mm	+/- 2mm
	1001mm & ABOVE	+/- 3mm
	ANGULAR	+/- 1°
MACHINING	+/- 0.2mm	
GAUGE	+/- 10%	
WEIGHT	+/- 10% (DUE TO MATERIAL PROPERTIES & TOLERANCES)	

TITLE: STRAP HOOK			
NAME	SIGNATURE	DATE	MATERIAL:
G. CRICK		19/12/13	CARBON STEEL
CHK'D			
FINISH: NONE			

ZNDUK_e	
Drw / Stockcode No.	Revision
ZNDDE0120-9	1

THE COMPANY RETAIN THE RIGHT TO PERIODICALLY ALTER INFORMATION WITHIN THIS DRAWING SHEET AND WILL ATTEMPT TO NOTIFY ALL PARTIES CONCERNED OF ANY CHANGES AND THE INFORMATION ON THIS SHEET SHOULD NOT BE REPRODUCED WITHOUT THEIR WRITTEN CONSENT.

ALL DIMENSIONS IN MILLIMETRES
REMOVE ALL SHARP EDGES

THIRD ANGLE PROJECTION
DO NOT SCALE DRAWING



1	14/1/14	ISSUED FOR MANUFACTURE	GC		
0	19/12/13	ISSUED FOR MANUFACTURE	GC		
REV	DATE	DESCRIPTION	DRN	CHKD	APPR

TOLERANCES - UNLESS STATED OTHERWISE		TITLE:
UNTOLERANCED DIMENSIONS	+/- 2mm	LABEL
CUTTING LENGTHS	+/- 2mm	
FABRICATION	UP TO 300mm	+/- 1mm
	UP TO 1000mm	+/- 2mm
	1001mm & ABOVE	+/- 3mm
	ANGULAR	+/- 1°
MACHINING	+/- 0.2mm	DRAWN
GAUGE	+/- 10%	
WEIGHT	+/- 10% (DUE TO MATERIAL PROPERTIES & TOLERANCES)	NAME

DATE	19/12/13	SIGNATURE	
CHK'D			
FINISH:		ALUMINIUM	
NONE			

ZNDUK_e	
Drw / Stockcode No.	Revision
ZNDDE0120-10	1

THE COMPANY RETAIN THE RIGHT TO PERIODICALLY ALTER INFORMATION WITHIN THIS DRAWING SHEET AND WILL ATTEMPT TO NOTIFY ALL PARTIES CONCERNED OF ANY CHANGES AND THE INFORMATION ON THIS SHEET SHOULD NOT BE REPRODUCED WITHOUT THEIR WRITTEN CONSENT.