

1  
2  
3  
4  
5  
6  
7  
8

ALL DIMENSIONS IN MILLIMETRES  
REMOVE ALL SHARP EDGES

THIRD ANGLE PROJECTION  
DO NOT SCALE DRAWING

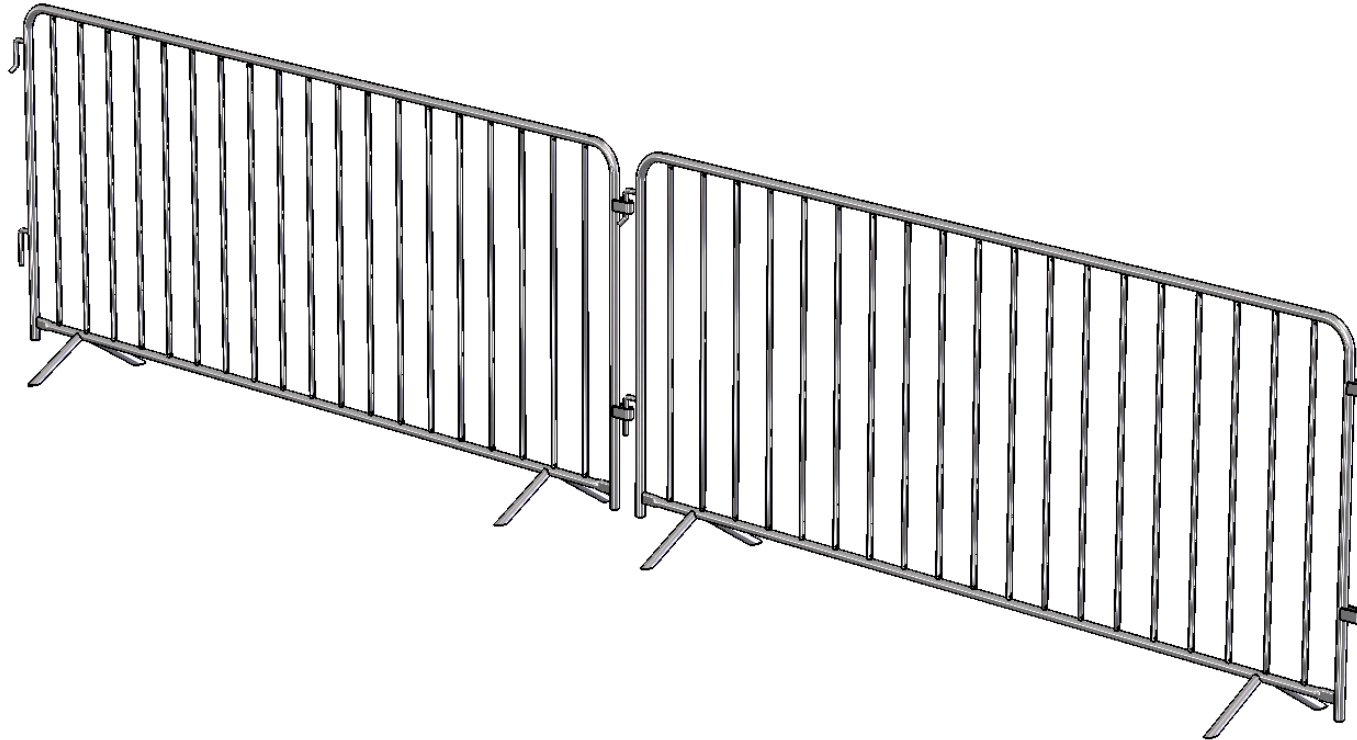

1	29/3/12	ISSUED FOR MANUFACTURE	GC	.	.
0	19/12/11	ISSUED FOR MANUFACTURE	GC	.	.
REV	DATE	DESCRIPTION	DRN	CHKD	APPR

TITLE:  
**MANNESMANN BARRIER LIGHT**

UNLESS STATED OTHERWISE		
GENERAL TOLERANCES:		
FABRICATION	UP TO 1000mm	+/- 2mm
	1001mm & ABOVE	+/- 3mm
ANGULAR	+/- 0.5 DEGREE	
WEIGHT	+/- 10% (DUE TO MATERIAL PROPERTIES & TOLERANCES)	

NAME	SIGNATURE	DATE
G. CRICK		8/12/11
CHK'D		
FINISH:	HOT DIPPED GALVANISED	

MATERIAL:  
**CARBON STEEL**



**CODE No. 1078**

THE COMPANY RETAIN THE RIGHT TO PERIODICALLY ALTER INFORMATION WITHIN THIS DRAWING SHEET AND WILL ATTEMPT TO NOTIFY ALL PARTIES CONCERNED OF ANY CHANGES AND THE INFORMATION ON THIS SHEET SHOULD NOT BE REPRODUCED WITHOUT THEIR WRITTEN CONSENT.

Dwg/Stock No.	Revision
<b>ZND510 - GA</b>	<b>1</b>

WEIGHT: 16 Kg      SCALE: 1:12.5      SHEET 1 OF 10      A3

ALL DIMENSIONS IN MILLIMETRES  
REMOVE ALL SHARP EDGES

THIRD ANGLE PROJECTION  
DO NOT SCALE DRAWING

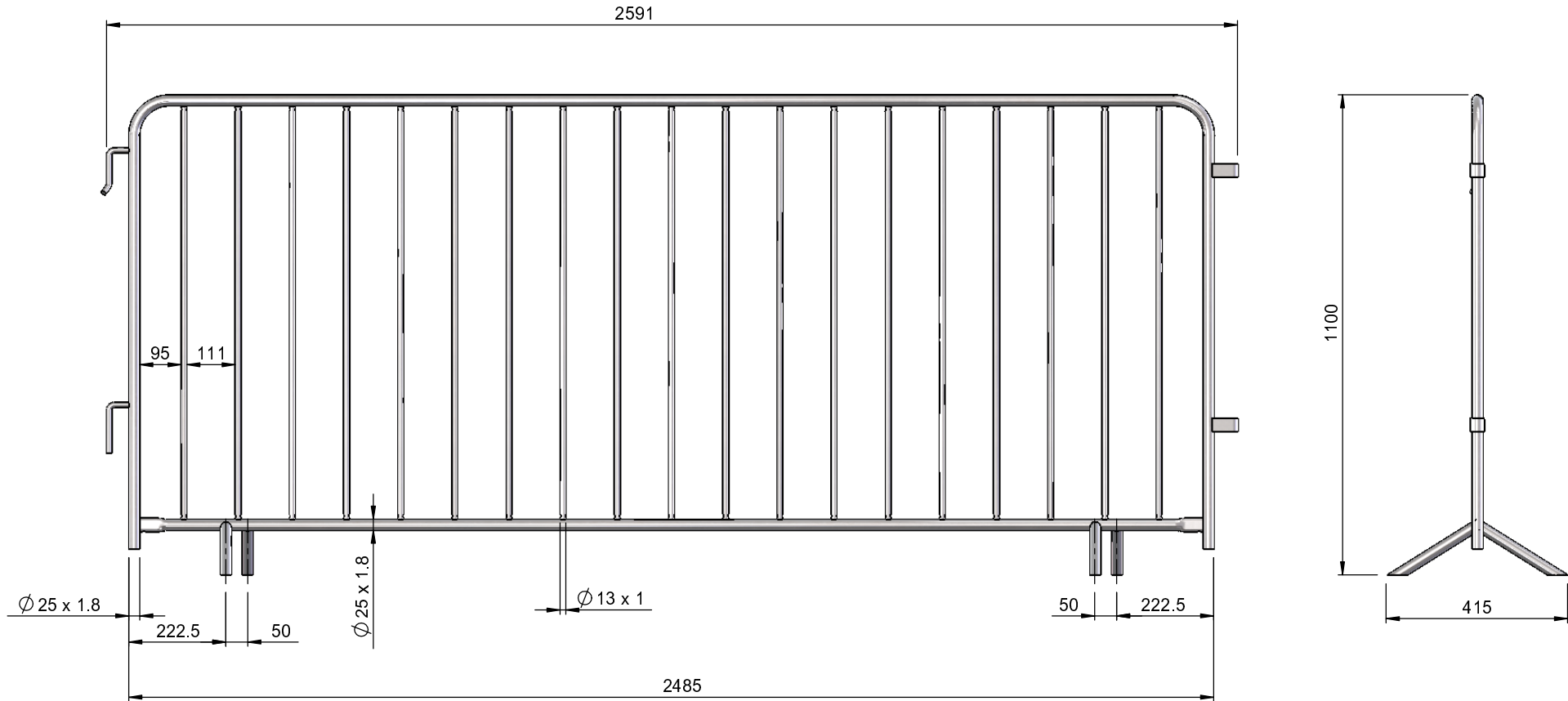

1	29/3/12	ISSUED FOR MANUFACTURE	GC		
0	19/12/11	ISSUED FOR MANUFACTURE	GC		
REV	DATE	DESCRIPTION	DRN	CHKD	APPR

TITLE:  
**MANNESMAN BARRIER LIGHT**

UNLESS STATED OTHERWISE		
GENERAL TOLERANCES:		
FABRICATION	UP TO 1000mm	+/- 2mm
	1001mm & ABOVE	+/- 3mm
ANGULAR	+/- 0.5 DEGREE	
WEIGHT	+/- 10% (DUE TO MATERIAL PROPERTIES & TOLERANCES)	

NAME	SIGNATURE	DATE
G. CRICK		8/12/11
CHK'D		
FINISH:	HOT DIPPED GALVANISED	

MATERIAL:  
**CARBON STEEL**



CODE No. 1078

Dwg/Stock No.	Revision
ZND510	1

THE COMPANY RETAIN THE RIGHT TO PERIODICALLY ALTER INFORMATION WITHIN THIS DRAWING SHEET AND WILL ATTEMPT TO NOTIFY ALL PARTIES CONCERNED OF ANY CHANGES AND THE INFORMATION ON THIS SHEET SHOULD NOT BE REPRODUCED WITHOUT THEIR WRITTEN CONSENT.

ALL DIMENSIONS IN MILLIMETRES  
REMOVE ALL SHARP EDGES

THIRD ANGLE PROJECTION  
DO NOT SCALE DRAWING



SECTION 1-1  
SCALE 1 : 2.5

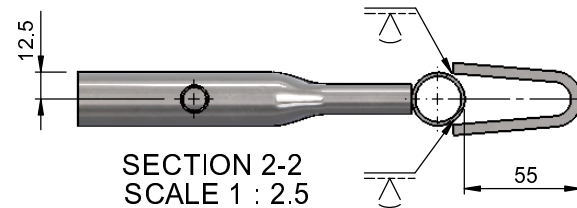

SECTION 2-2  
SCALE 1 : 2.5

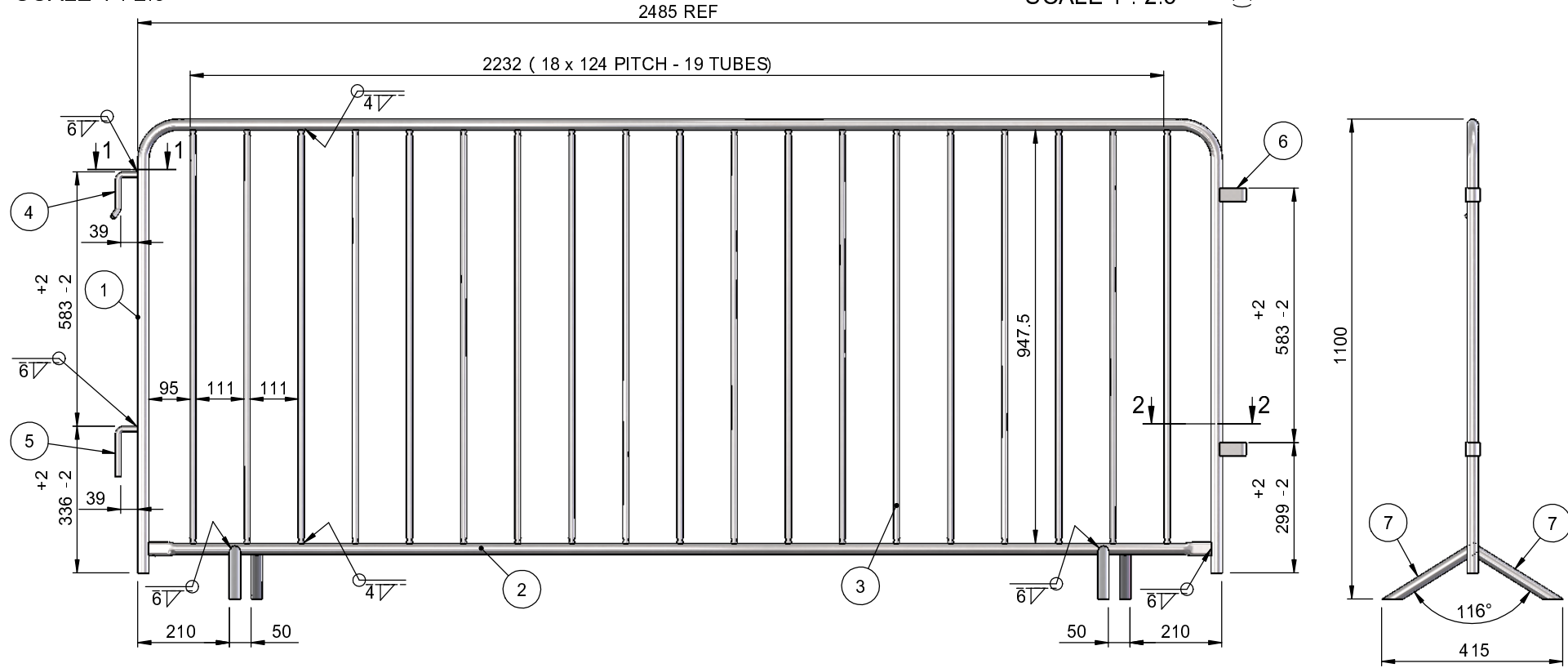

ITEM No.	PART No.	DESCRIPTION	QTY
1	ZND510-1	FRAME TUBE	1
2	ZND510-2	BOTTOM TUBE	1
3	ZND510-3	VERTICAL TUBE	19
4	ZND510-4	TOP HOOK	1
5	ZND510-5	BOTTOM HOOK	1
6	ZND510-6	EYE	2
7	ZND510-7	FOOT	4

REV	DATE	DESCRIPTION	DRN	CHKD	APPR
1	29/3/12	ISSUED FOR MANUFACTURE	GC		
0	19/12/11	ISSUED FOR MANUFACTURE	GC		

TITLE: **MANNESMANN BARRIER LIGHT - FABRICATION**

NAME	SIGNATURE	DATE	MATERIAL:
G. CRICK		8/12/11	CARBON STEEL
FINISH:	HOT DIPPED GALVANISED		



Dwg/Stock No. **ZND510 - FAB** Revision **1**

UNLESS STATED OTHERWISE

GENERAL TOLERANCES:		
FABRICATION	UP TO 1000mm	+/- 2mm
	1001mm & ABOVE	+/- 3mm
ANGULAR	+/- 0.5 DEGREE	
WEIGHT	+/- 10% (DUE TO MATERIAL PROPERTIES & TOLERANCES)	

THE COMPANY RETAIN THE RIGHT TO PERIODICALLY ALTER INFORMATION WITHIN THIS DRAWING SHEET AND WILL ATTEMPT TO NOTIFY ALL PARTIES CONCERNED OF ANY CHANGES AND THE INFORMATION ON THIS SHEET SHOULD NOT BE REPRODUCED WITHOUT THEIR WRITTEN CONSENT.

ALL DIMENSIONS IN MILLIMETRES  
REMOVE ALL SHARP EDGES

THIRD ANGLE PROJECTION  
DO NOT SCALE DRAWING

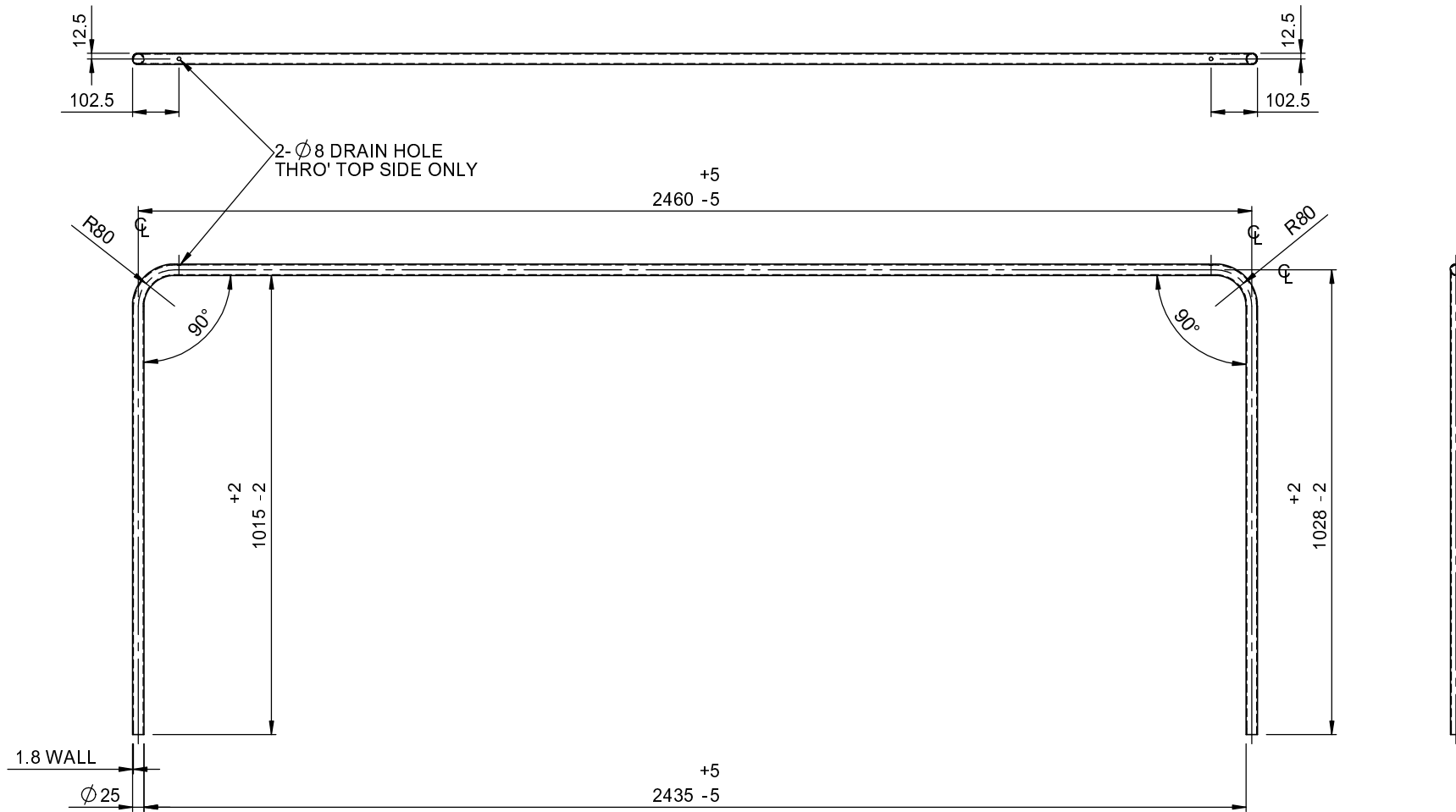

REV	DATE	DESCRIPTION	DRN	CHKD	APPR
1	29/3/12	ISSUED FOR MANUFACTURE	GC		
0	19/12/11	ISSUED FOR MANUFACTURE	GC		

TITLE: **FRAME TUBE**

UNLESS STATED OTHERWISE		
GENERAL TOLERANCES:		
FABRICATION	UP TO 1000mm	+/- 2mm
	1001mm & ABOVE	+/- 3mm
ANGULAR	+/- 0.5 DEGREE	
WEIGHT	+/- 10% (DUE TO MATERIAL PROPERTIES & TOLERANCES)	

NAME	SIGNATURE	DATE
DRAWN G. CRICK		8/12/11
CHK'D		
FINISH: NONE		

MATERIAL: **CARBON STEEL**



Dwg/Stock No.	Revision
ZND510-1	1

THE COMPANY RETAIN THE RIGHT TO PERIODICALLY ALTER INFORMATION WITHIN THIS DRAWING SHEET AND WILL ATTEMPT TO NOTIFY ALL PARTIES CONCERNED OF ANY CHANGES AND THE INFORMATION ON THIS SHEET SHOULD NOT BE REPRODUCED WITHOUT THEIR WRITTEN CONSENT.

ALL DIMENSIONS IN MILLIMETRES  
REMOVE ALL SHARP EDGES

THIRD ANGLE PROJECTION  
DO NOT SCALE DRAWING

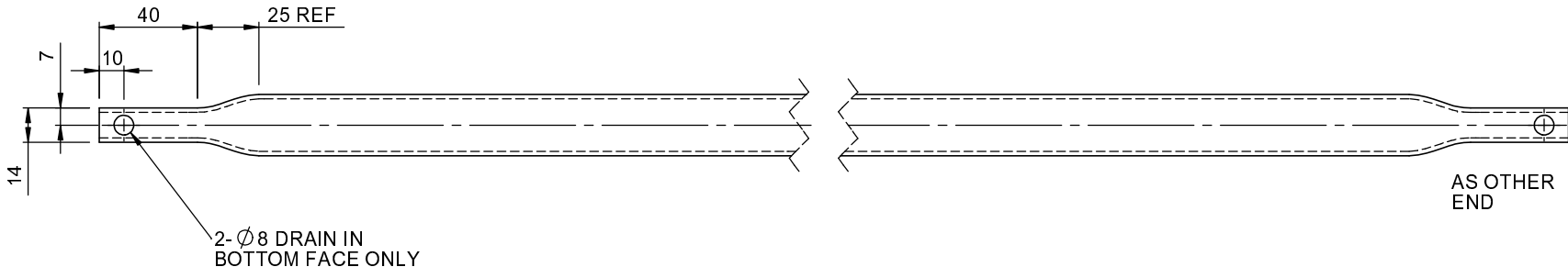
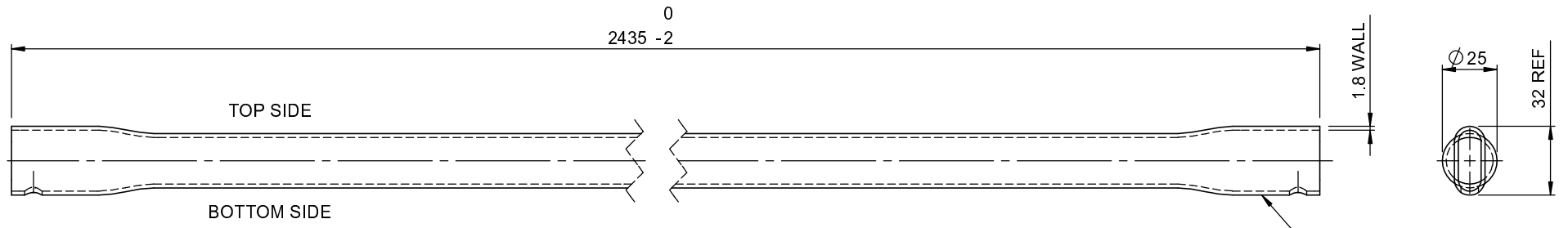

1	29/3/12	ISSUED FOR MANUFACTURE	GC		
0	19/12/11	ISSUED FOR MANUFACTURE	GC		
REV	DATE	DESCRIPTION	DRN	CHKD	APPR

TITLE: **BOTTOM TUBE**

UNLESS STATED OTHERWISE		
GENERAL TOLERANCES:		
FABRICATION	UP TO 1000mm	+/- 2mm
	1001mm & ABOVE	+/- 3mm
ANGULAR	+/- 0.5 DEGREE	
WEIGHT	+/- 10% (DUE TO MATERIAL PROPERTIES & TOLERANCES)	

DRAWN	NAME	SIGNATURE	DATE
CHK'D	G. CRICK		8/12/11
FINISH:			
NONE			

MATERIAL:  
**CARBON STEEL**



Dwg/Stock No. **ZND510-2** Revision **1**

THE COMPANY RETAIN THE RIGHT TO PERIODICALLY ALTER INFORMATION WITHIN THIS DRAWING SHEET AND WILL ATTEMPT TO NOTIFY ALL PARTIES CONCERNED OF ANY CHANGES AND THE INFORMATION ON THIS SHEET SHOULD NOT BE REPRODUCED WITHOUT THEIR WRITTEN CONSENT.

ALL DIMENSIONS IN MILLIMETRES  
REMOVE ALL SHARP EDGES

THIRD ANGLE PROJECTION  
DO NOT SCALE DRAWING

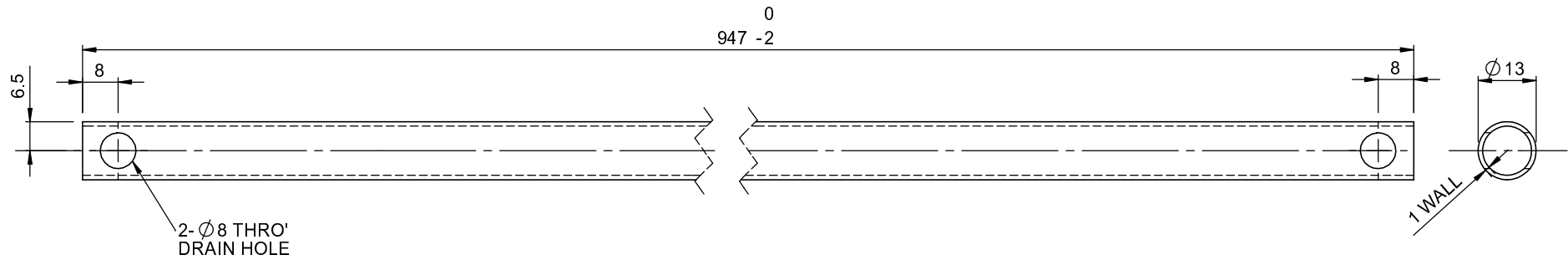

1	29/3/12	ISSUED FOR MANUFACTURE	GC		
0	19/12/11	ISSUED FOR MANUFACTURE	GC		
REV	DATE	DESCRIPTION	DRN	CHKD	APPR

TITLE: **VERTICAL TUBE**

UNLESS STATED OTHERWISE		
GENERAL TOLERANCES:		
FABRICATION	UP TO 1000mm	+/- 2mm
	1001mm & ABOVE	+/- 3mm
ANGULAR	+/- 0.5 DEGREE	
WEIGHT	+/- 10% (DUE TO MATERIAL PROPERTIES & TOLERANCES)	

DRAWN	NAME	SIGNATURE	DATE
CHK'D	G. CRICK		8/12/11
FINISH: NONE			

MATERIAL: **CARBON STEEL**



Dwg/Stock No. **ZND510-3** Revision **1**

THE COMPANY RETAIN THE RIGHT TO PERIODICALLY ALTER INFORMATION WITHIN THIS DRAWING SHEET AND WILL ATTEMPT TO NOTIFY ALL PARTIES CONCERNED OF ANY CHANGES AND THE INFORMATION ON THIS SHEET SHOULD NOT BE REPRODUCED WITHOUT THEIR WRITTEN CONSENT.

ALL DIMENSIONS IN MILLIMETRES  
REMOVE ALL SHARP EDGES

THIRD ANGLE PROJECTION  
DO NOT SCALE DRAWING

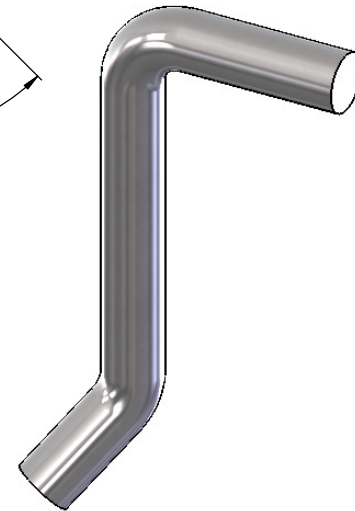
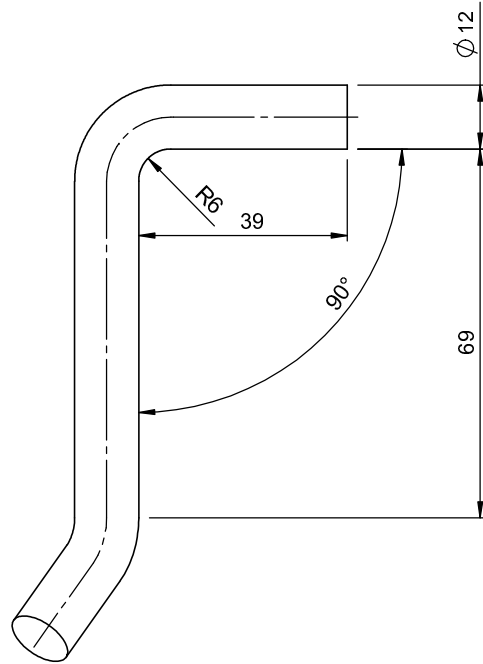
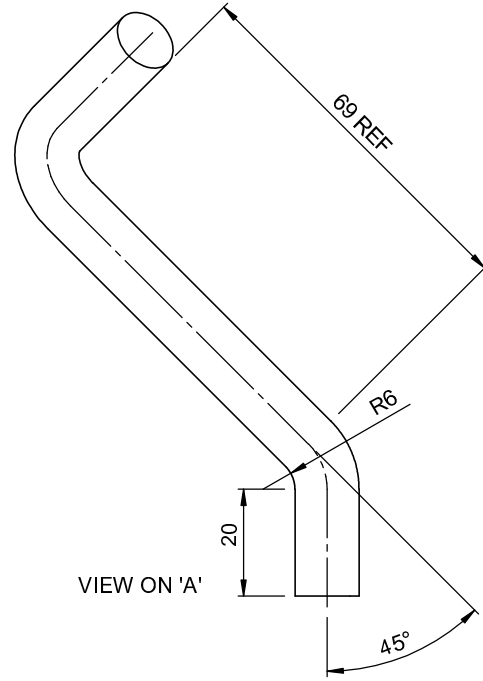
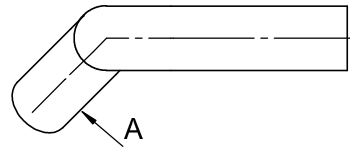

1	29/3/12	ISSUED FOR MANUFACTURE	GC		
0	19/12/11	ISSUED FOR MANUFACTURE	GC		
REV	DATE	DESCRIPTION	DRN	CHKD	APPR

TITLE: **TOP HOOK**

UNLESS STATED OTHERWISE		
GENERAL TOLERANCES:		
FABRICATION	UP TO 1000mm	+/- 2mm
	1001mm & ABOVE	+/- 3mm
ANGULAR	+/- 0.5 DEGREE	
WEIGHT	+/- 10% (DUE TO MATERIAL PROPERTIES & TOLERANCES)	

DRAWN	NAME	SIGNATURE	DATE
CHK'D	G. CRICK		8/12/11
FINISH:			
NONE			

MATERIAL:  
**CARBON STEEL**



Dwg/Stock No.	Revision
<b>ZND510-4</b>	<b>1</b>

THE COMPANY RETAIN THE RIGHT TO PERIODICALLY ALTER INFORMATION WITHIN THIS DRAWING SHEET AND WILL ATTEMPT TO NOTIFY ALL PARTIES CONCERNED OF ANY CHANGES AND THE INFORMATION ON THIS SHEET SHOULD NOT BE REPRODUCED WITHOUT THEIR WRITTEN CONSENT.

1  
2  
3  
4  
5  
6  
7  
8

ALL DIMENSIONS IN MILLIMETRES  
REMOVE ALL SHARP EDGES

THIRD ANGLE PROJECTION  
DO NOT SCALE DRAWING

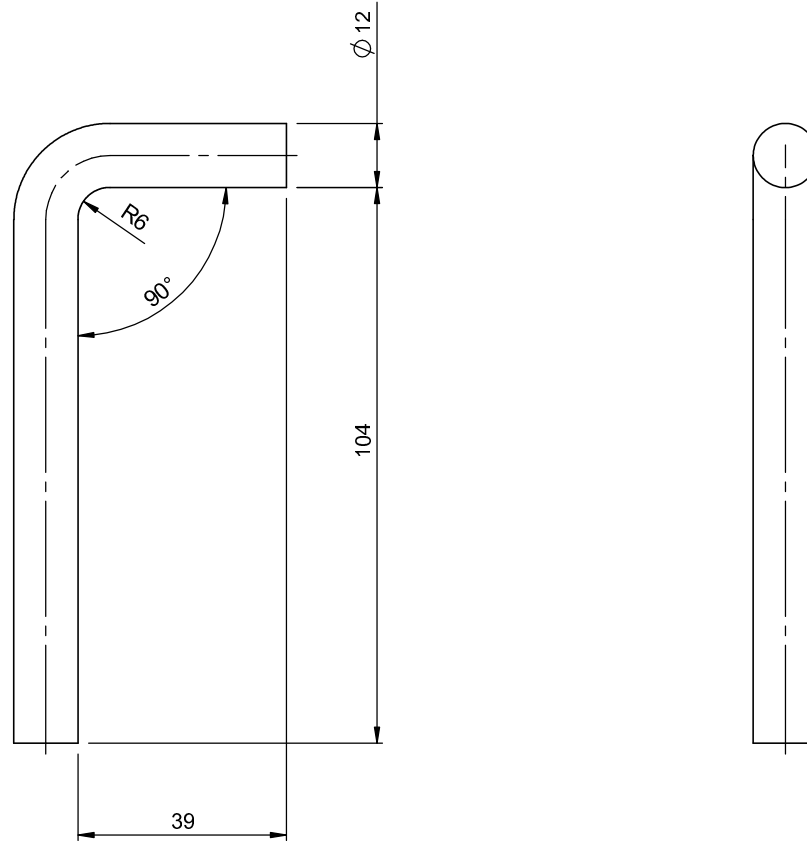

1	29/3/12	ISSUED FOR MANUFACTURE	GC	.	.
0	19/12/11	ISSUED FOR MANUFACTURE	GC	.	.
REV	DATE	DESCRIPTION	DRN	CHKD	APPR

TITLE:  
**BOTTOM HOOK**

UNLESS STATED OTHERWISE		
GENERAL TOLERANCES:		
FABRICATION	UP TO 1000mm	+/- 2mm
	1001mm & ABOVE	+/- 3mm
ANGULAR	+/- 0.5 DEGREE	
WEIGHT	+/- 10% (DUE TO MATERIAL PROPERTIES & TOLERANCES)	

DRAWN	NAME	SIGNATURE	DATE
CHK'D	G. CRICK		8/12/11
FINISH:	NONE		

MATERIAL:  
**CARBON STEEL**



Dwg/Stock No.	Revision
<b>ZND510-5</b>	<b>1</b>

THE COMPANY RETAIN THE RIGHT TO PERIODICALLY ALTER INFORMATION WITHIN THIS DRAWING SHEET AND WILL ATTEMPT TO NOTIFY ALL PARTIES CONCERNED OF ANY CHANGES AND THE INFORMATION ON THIS SHEET SHOULD NOT BE REPRODUCED WITHOUT THEIR WRITTEN CONSENT.



1  
2  
3  
4  
5  
6  
7  
8

ALL DIMENSIONS IN MILLIMETRES  
REMOVE ALL SHARP EDGES

THIRD ANGLE PROJECTION  
DO NOT SCALE DRAWING

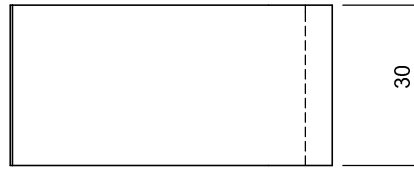
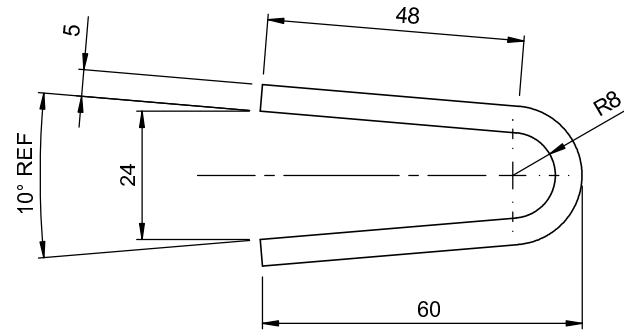

1	29/3/12	ISSUED FOR MANUFACTURE	GC	.	.
0	19/12/11	ISSUED FOR MANUFACTURE	GC	.	.
REV	DATE	DESCRIPTION	DRN	CHKD	APPR

TITLE: **EYE**

UNLESS STATED OTHERWISE		
GENERAL TOLERANCES:		
FABRICATION	UP TO 1000mm	+/- 2mm
	1001mm & ABOVE	+/- 3mm
ANGULAR	+/- 0.5 DEGREE	
WEIGHT	+/- 10% (DUE TO MATERIAL PROPERTIES & TOLERANCES)	

NAME	SIGNATURE	DATE
G. CRICK		8/12/11
CHK'D		
FINISH:		
NONE		

MATERIAL:  
**CARBON STEEL**



Dwg/Stock No.	Revision
<b>ZND510-6</b>	<b>1</b>

THE COMPANY RETAIN THE RIGHT TO PERIODICALLY ALTER INFORMATION WITHIN THIS DRAWING SHEET AND WILL ATTEMPT TO NOTIFY ALL PARTIES CONCERNED OF ANY CHANGES AND THE INFORMATION ON THIS SHEET SHOULD NOT BE REPRODUCED WITHOUT THEIR WRITTEN CONSENT.

1  
2  
3  
4  
5  
6  
7  
8

ALL DIMENSIONS IN MILLIMETRES  
REMOVE ALL SHARP EDGES

THIRD ANGLE PROJECTION  
DO NOT SCALE DRAWING

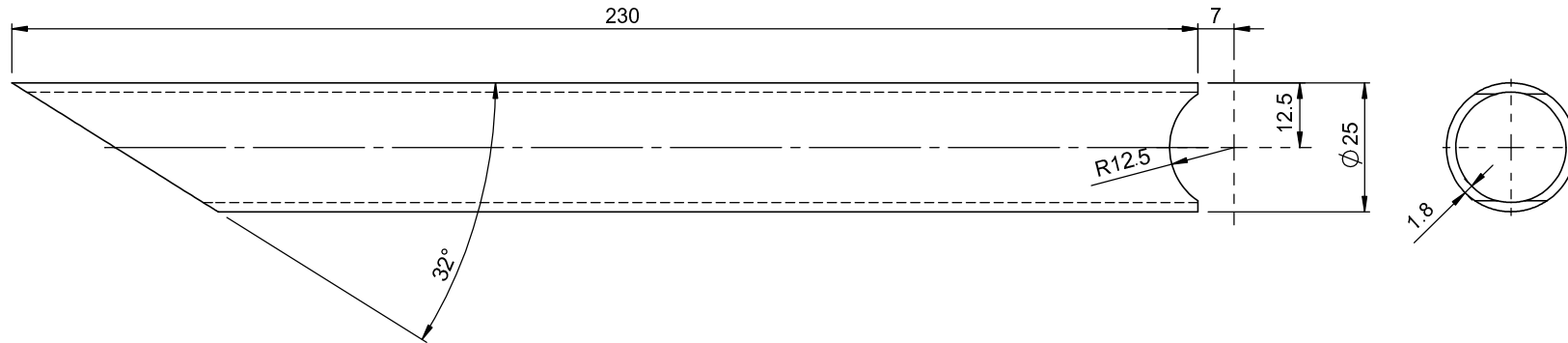

1	29/3/12	ISSUED FOR MANUFACTURE	GC		
0	19/12/11	ISSUED FOR MANUFACTURE	GC		
REV	DATE	DESCRIPTION	DRN	CHKD	APPR

TITLE: **BARRIER FOOT**

UNLESS STATED OTHERWISE		
GENERAL TOLERANCES:		
FABRICATION	UP TO 1000mm	+/- 2mm
	1001mm & ABOVE	+/- 3mm
ANGULAR	+/- 0.5 DEGREE	
WEIGHT	+/- 10% (DUE TO MATERIAL PROPERTIES & TOLERANCES)	

DRAWN	NAME	SIGNATURE	DATE
CHK'D	G. CRICK		8/12/11
FINISH:	HOT DIPPED GALVANISED		

MATERIAL: **CARBON STEEL**



Dwg/Stock No.	Revision
<b>ZND510-7</b>	<b>1</b>

THE COMPANY RETAIN THE RIGHT TO PERIODICALLY ALTER INFORMATION WITHIN THIS DRAWING SHEET AND WILL ATTEMPT TO NOTIFY ALL PARTIES CONCERNED OF ANY CHANGES AND THE INFORMATION ON THIS SHEET SHOULD NOT BE REPRODUCED WITHOUT THEIR WRITTEN CONSENT.