

ALL DIMENSIONS IN MILLIMETRES
REMOVE ALL SHARP EDGES

THIRD ANGLE PROJECTION
DO NOT SCALE DRAWING

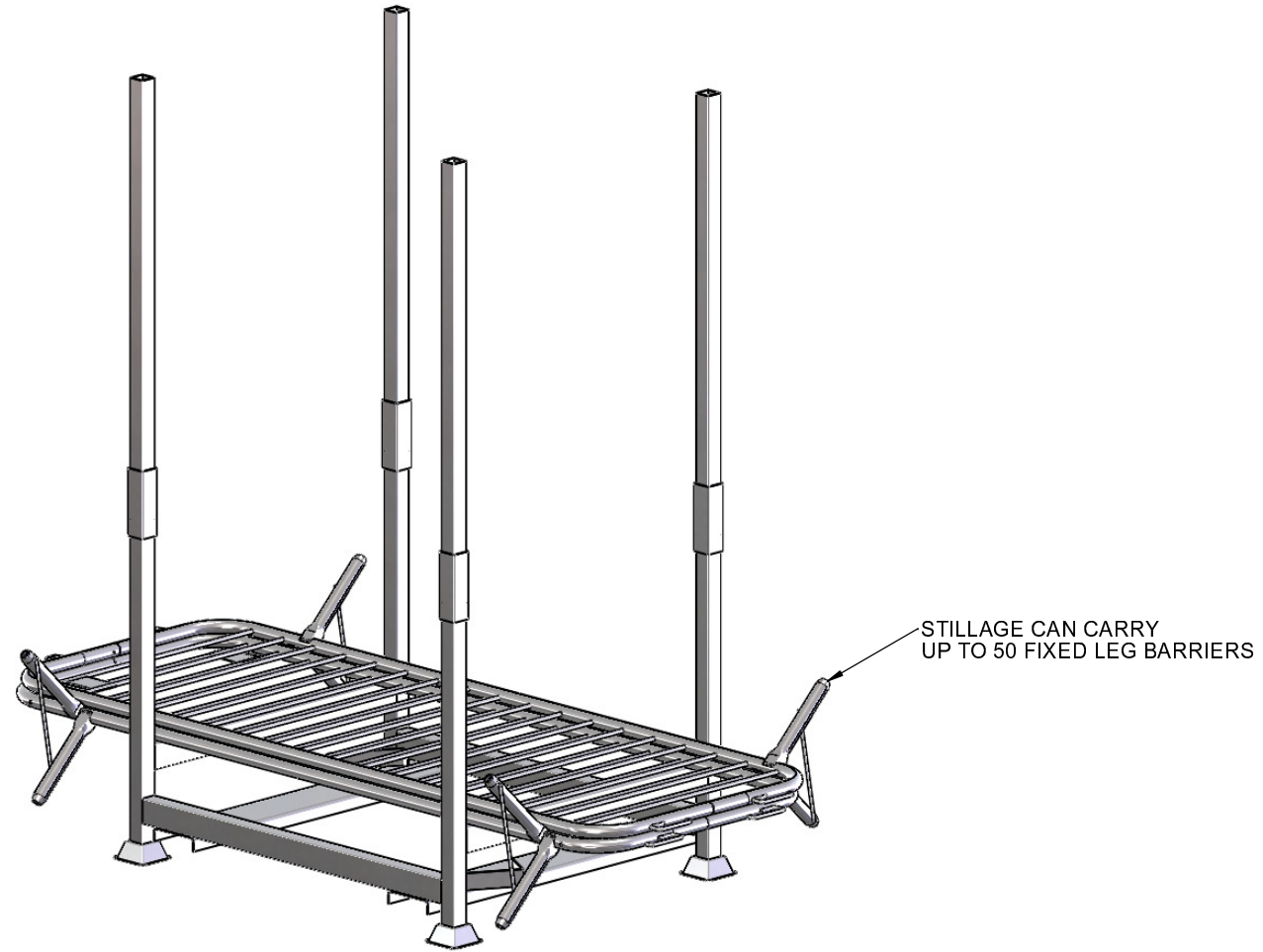

NOTE:
THIS STILLAGE IS NOT DESIGNED TO BE STACKED
2 HIGH WHEN FULLY LOADED. IT CAN ONLY BE STACKED
WHEN EMPTY OF BARRIERS AND THE LEGS ARE STORED
INSIDE THE STILLAGE BODY.

0	17/2/12	ISSUED FOR MANUFACTURE	GC		
P1	16/2/12	ISSUED FOR APPROVAL	GC		
REV	DATE	DESCRIPTION	DRN	CHKD	APPR

TITLE: FIXED LEG BARRIER STILLAGE				MATERIAL: CARBON STEEL	
DRAWN	NAME	SIGNATURE	DATE		
CHK'D	G. CRICK		16/2/12		
FINISH:	NONE				
WEIGHT: 79.3 Kg					



CODE No. 1091

Dwg/Stock No.	Revision
ZND524 - GA	0

THE COMPANY RETAIN THE RIGHT TO PERIODICALLY ALTER INFORMATION WITHIN THIS DRAWING SHEET AND WILL ATTEMPT TO NOTIFY ALL PARTIES CONCERNED OF ANY CHANGES AND THE INFORMATION ON THIS SHEET SHOULD NOT BE REPRODUCED WITHOUT THEIR WRITTEN CONSENT.

ALL DIMENSIONS IN MILLIMETRES
REMOVE ALL SHARP EDGES

THIRD ANGLE PROJECTION
DO NOT SCALE DRAWING

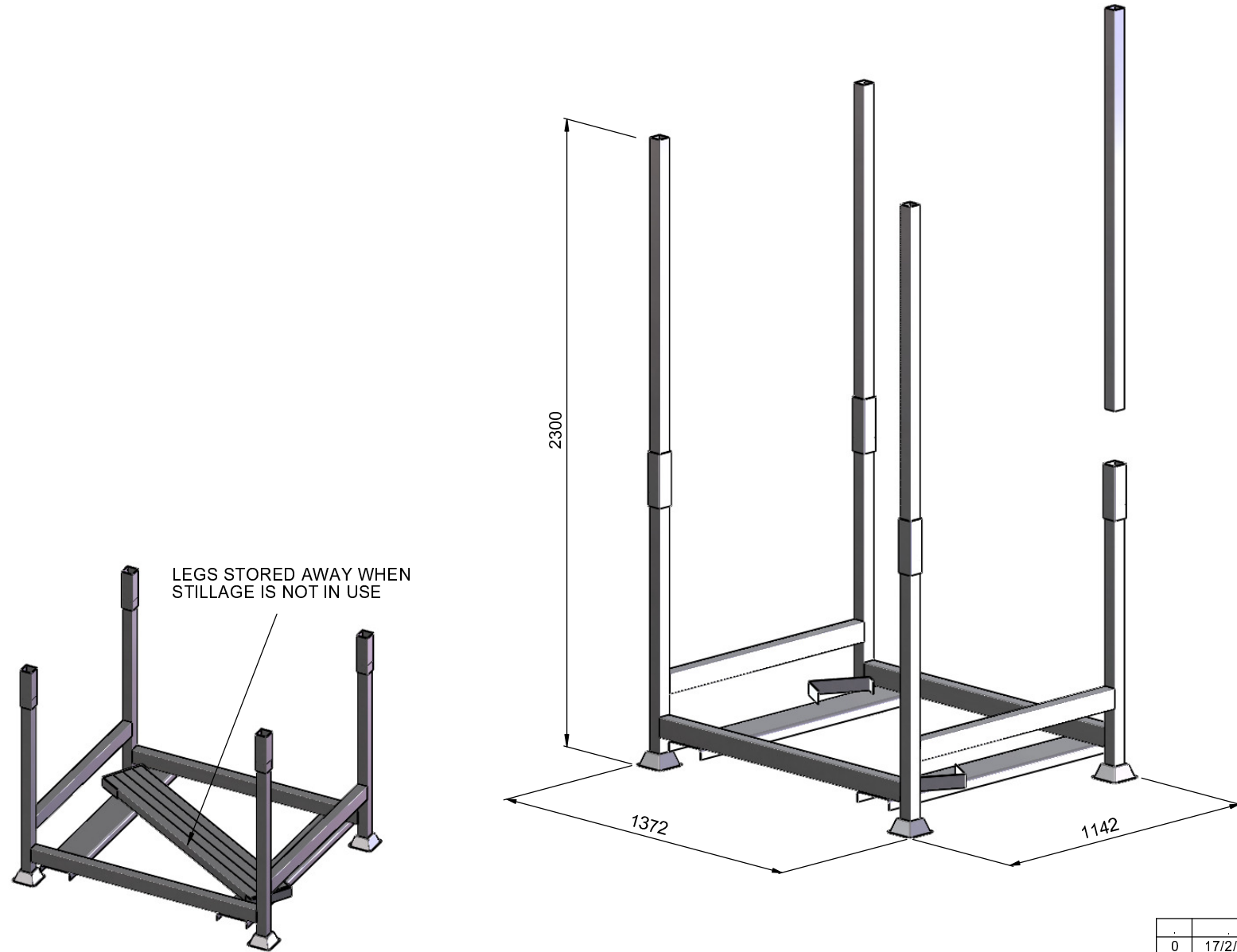

NOTE:
THIS STILLAGE IS NOT DESIGNED TO BE STACKED
2 HIGH WHEN FULLY LOADED. IT CAN ONLY BE STACKED
WHEN EMPTY OF BARRIERS AND THE LEGS ARE STORED
INSIDE THE STILLAGE BODY.

CODE No. 1091

THE COMPANY RETAIN THE RIGHT TO PERIODICALLY ALTER INFORMATION WITHIN THIS DRAWING SHEET AND WILL ATTEMPT TO NOTIFY ALL PARTIES CONCERNED OF ANY CHANGES AND THE INFORMATION ON THIS SHEET SHOULD NOT BE REPRODUCED WITHOUT THEIR WRITTEN CONSENT.

UNLESS STATED OTHERWISE		
GENERAL TOLERANCES:		
FABRICATION	UP TO 1000mm	+/- 2mm
	1001mm & ABOVE	+/- 3mm
ANGULAR	+/- 0.5 DEGREE	
WEIGHT	+/- 10% (DUE TO MATERIAL PROPERTIES & TOLERANCES)	

TITLE: FIXED LEG BARRIER STILLAGE			
DRAWN	NAME	SIGNATURE	DATE
CHK'D	G. CRICK		17/2/12
FINISH:		MATERIAL:	
NONE		CARBON STEEL	
WEIGHT: 79.3 Kg			



Dwg/Stock No.	Revision
ZND524	0

0	17/2/12	ISSUED FOR MANUFACTURE	GC		
REV	DATE	DESCRIPTION	DRN	CHKD	APPR

ALL DIMENSIONS IN MILLIMETRES
REMOVE ALL SHARP EDGES

THIRD ANGLE PROJECTION
DO NOT SCALE DRAWING

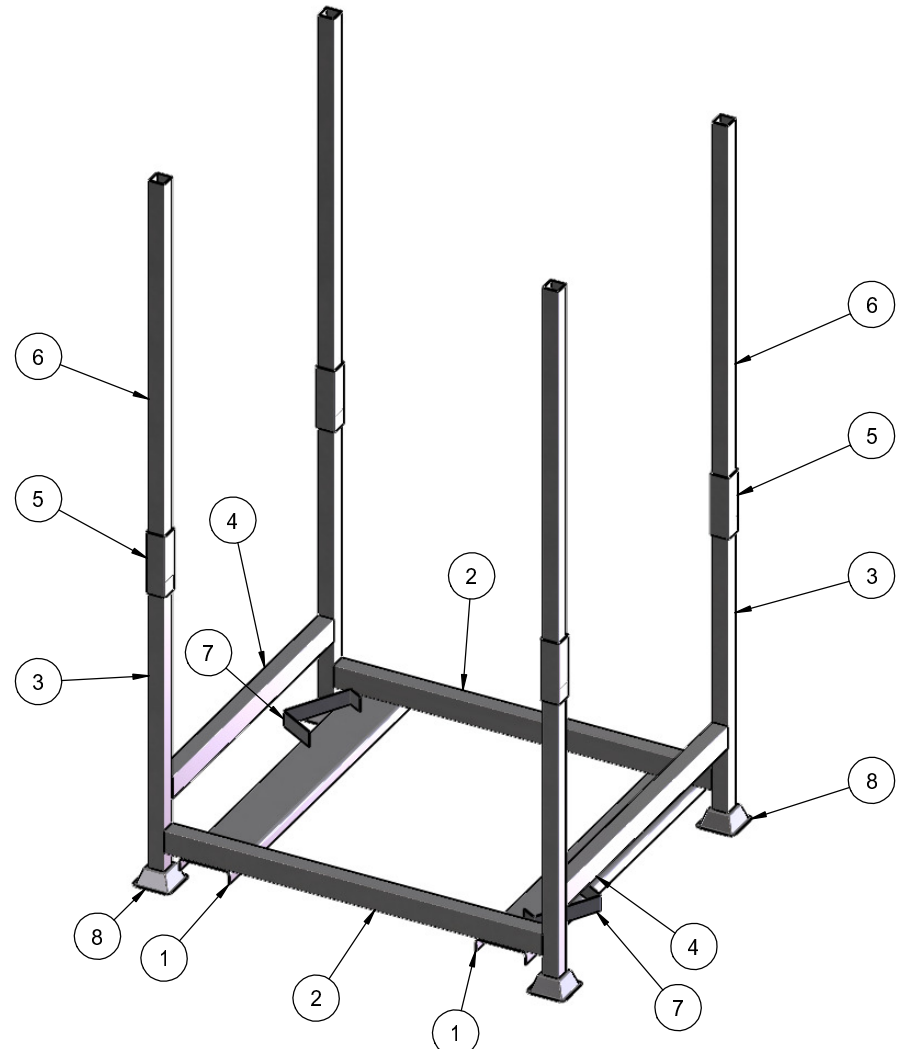

ITEM No.	PART No.	DESCRIPTION	QTY	SIZE
1	ZND524-1	FRAME PT 1	2	SEE DETAIL
2	ZND524-2	FRAME PT 2	2	75 x 50 x 3 RHS x 1200 Lg
3	ZND524-3	FRAME PT 3	4	50 x 50 x 3 SHS x 950 Lg
4	ZND524-4	FRAME PT 4	2	75 x 50 X 3 RHS x 970 Lg
5	ZND524-5	FRAME PT 5	4	60 x 60 x 3 SHS x 200 Lg
6	ZND524-6	LOOSE LEG	4	50 x 50 x 3 SHS x 1300 Lg
7	ZND524-7	LEG GUIDE	4	SEE DETAIL
8	ZND524-9	STILLAGE FOOT	1	SEE DETAIL

CODE No. 1091

THE COMPANY RETAIN THE RIGHT TO PERIODICALLY ALTER INFORMATION WITHIN THIS DRAWING SHEET AND WILL ATTEMPT TO NOTIFY ALL PARTIES CONCERNED OF ANY CHANGES AND THE INFORMATION ON THIS SHEET SHOULD NOT BE REPRODUCED WITHOUT THEIR WRITTEN CONSENT.

UNLESS STATED OTHERWISE		
GENERAL TOLERANCES:		
FABRICATION	UP TO 1000mm	+/- 2mm
	1001mm & ABOVE	+/- 3mm
ANGULAR	+/- 0.5 DEGREE	
WEIGHT	+/- 10% (DUE TO MATERIAL PROPERTIES & TOLERANCES)	

TITLE: FIXED LEG BARRIER STILLAGE - FAB SHT 1			
NAME	SIGNATURE	DATE	MATERIAL:
G. CRICK		17/2/12	CARBON STEEL
CHK'D			
FINISH:		NONE	

0	17/2/12	ISSUED FOR MANUFACTURE	GC		
REV	DATE	DESCRIPTION	DRN	CHKD	APPR



Dwg/Stock No.	Revision
ZND524 - FAB SHT1	0

ALL DIMENSIONS IN MILLIMETRES
REMOVE ALL SHARP EDGES

THIRD ANGLE PROJECTION
DO NOT SCALE DRAWING

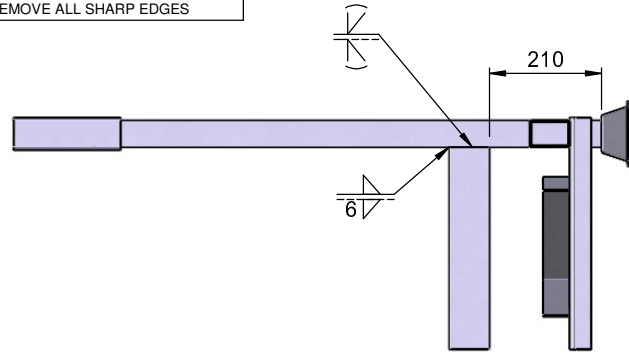

SECTION 1-1
SCALE 1 : 10

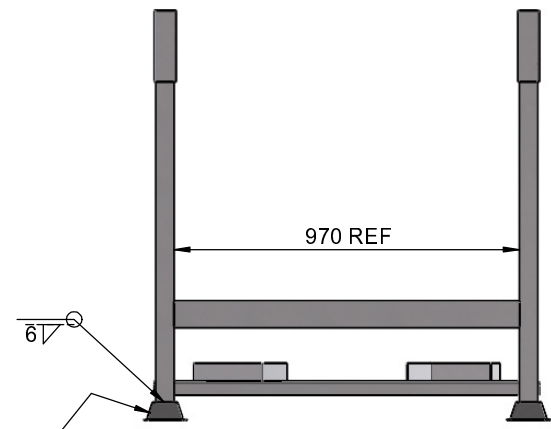
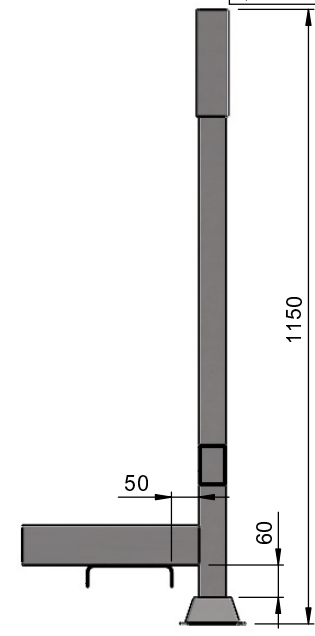
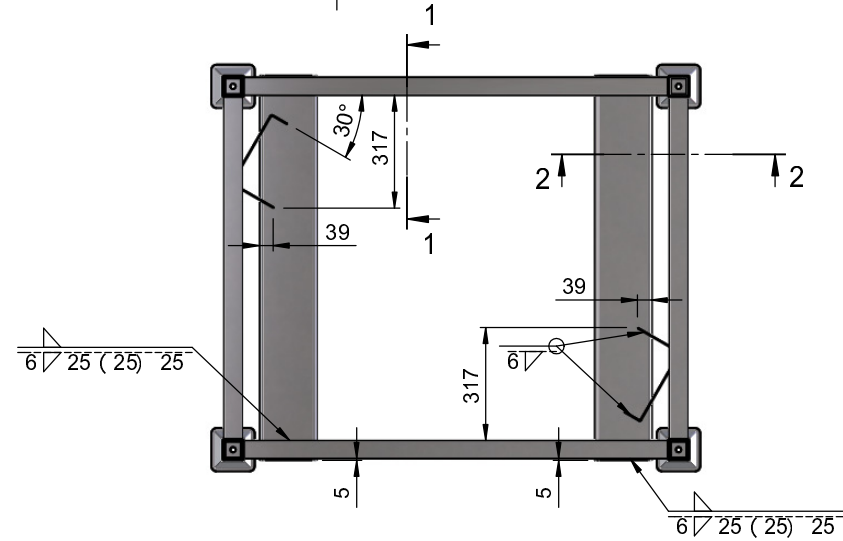

FEET TO BE POSITIONED
CENTRAL OF CORNER LEGS

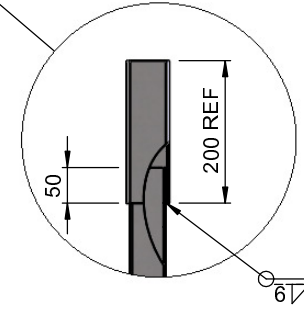
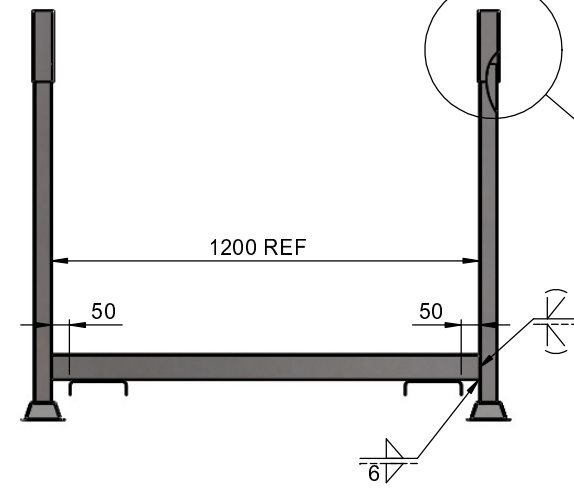

0	17/2/12	ISSUED FOR MANUFACTURE	GC		
REV	DATE	DESCRIPTION	DRN	CHKD	APPR

TITLE: FIXED LEG BARRIER STILLAGE - FAB SHT 2				MATERIAL: CARBON STEEL	
NAME	SIGNATURE	DATE			
G. CRICK		17/2/12			
CHK'D					
FINISH:	NONE				

ZNDDE

Dwg/Stock No. **ZND524 - FAB SHT2** Revision **0**

CODE No. 1091

UNLESS STATED OTHERWISE		
GENERAL TOLERANCES:		
FABRICATION	UP TO 1000mm	+/- 2mm
	1001mm & ABOVE	+/- 3mm
ANGULAR	+/- 0.5 DEGREE	
WEIGHT	+/- 10% (DUE TO MATERIAL PROPERTIES & TOLERANCES)	

WEIGHT: 79.3 Kg

SCALE: 1:15

SHEET 4 OF 7

A3

THE COMPANY RETAIN THE RIGHT TO PERIODICALLY ALTER INFORMATION WITHIN THIS DRAWING SHEET AND WILL ATTEMPT TO NOTIFY ALL PARTIES CONCERNED OF ANY CHANGES AND THE INFORMATION ON THIS SHEET SHOULD NOT BE REPRODUCED WITHOUT THEIR WRITTEN CONSENT.

ALL DIMENSIONS IN MILLIMETRES
REMOVE ALL SHARP EDGES

THIRD ANGLE PROJECTION
DO NOT SCALE DRAWING

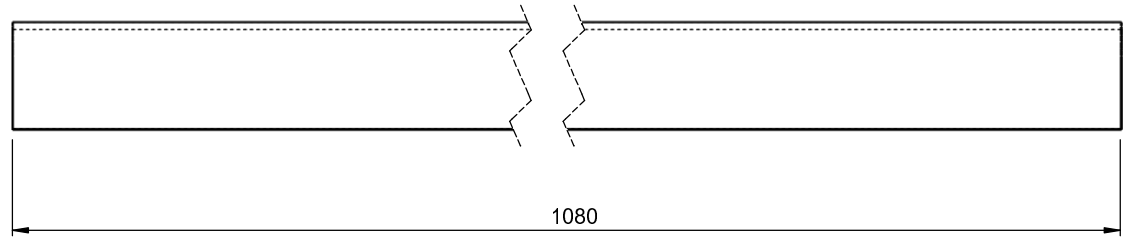
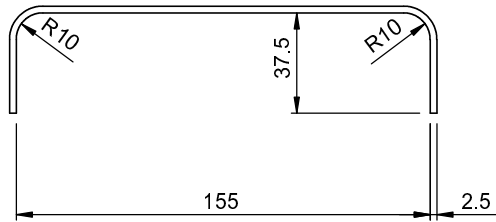

0	17/2/12	ISSUED FOR MANUFACTURE	GC		
REV	DATE	DESCRIPTION	DRN	CHKD	APPR

TITLE: **FRAME PART 1**

UNLESS STATED OTHERWISE		
GENERAL TOLERANCES:		
FABRICATION	UP TO 1000mm	+/- 2mm
	1001mm & ABOVE	+/- 3mm
ANGULAR	+/- 0.5 DEGREE	
WEIGHT	+/- 10% (DUE TO MATERIAL PROPERTIES & TOLERANCES)	

DRAWN	NAME	SIGNATURE	DATE
CHK'D	G. CRICK		17/2/12
FINISH:			
NONE			

MATERIAL:
CARBON STEEL



Dwg/Stock No.	Revision
ZND524-1	0

THE COMPANY RETAIN THE RIGHT TO PERIODICALLY ALTER INFORMATION WITHIN THIS DRAWING SHEET AND WILL ATTEMPT TO NOTIFY ALL PARTIES CONCERNED OF ANY CHANGES AND THE INFORMATION ON THIS SHEET SHOULD NOT BE REPRODUCED WITHOUT THEIR WRITTEN CONSENT.

ALL DIMENSIONS IN MILLIMETRES
REMOVE ALL SHARP EDGES

THIRD ANGLE PROJECTION
DO NOT SCALE DRAWING

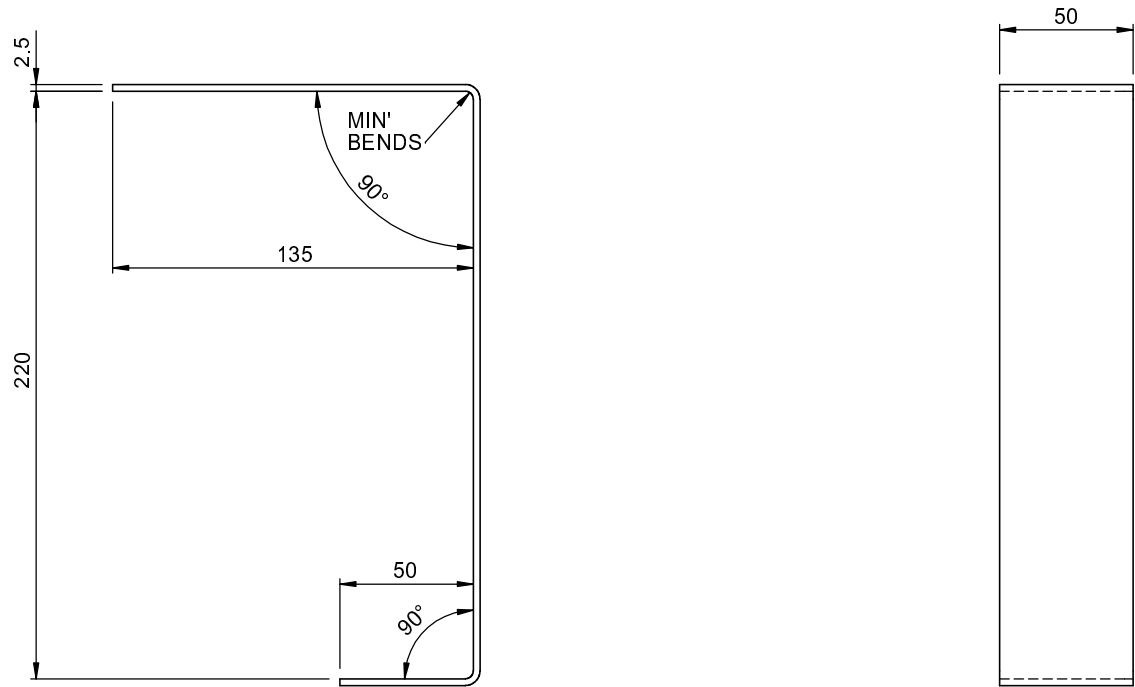

0	17/2/12	ISSUED FOR MANUFACTURE	GC		
REV	DATE	DESCRIPTION	DRN	CHKD	APPR

TITLE: **STILLAGE LEG GUIDE**

UNLESS STATED OTHERWISE		
GENERAL TOLERANCES:		
FABRICATION	UP TO 1000mm	+/- 2mm
	1001mm & ABOVE	+/- 3mm
ANGULAR	+/- 0.5 DEGREE	
WEIGHT	+/- 10% (DUE TO MATERIAL PROPERTIES & TOLERANCES)	

	NAME	SIGNATURE	DATE
DRAWN	G. CRICK		17/2/12
CHK'D			
FINISH: NONE			

MATERIAL: CARBON STEEL



Dwg/Stock No. **ZND524-7** Revision **0**

THE COMPANY RETAIN THE RIGHT TO PERIODICALLY ALTER INFORMATION WITHIN THIS DRAWING SHEET AND WILL ATTEMPT TO NOTIFY ALL PARTIES CONCERNED OF ANY CHANGES AND THE INFORMATION ON THIS SHEET SHOULD NOT BE REPRODUCED WITHOUT THEIR WRITTEN CONSENT.

ALL DIMENSIONS IN MILLIMETRES
REMOVE ALL SHARP EDGES

THIRD ANGLE PROJECTION
DO NOT SCALE DRAWING

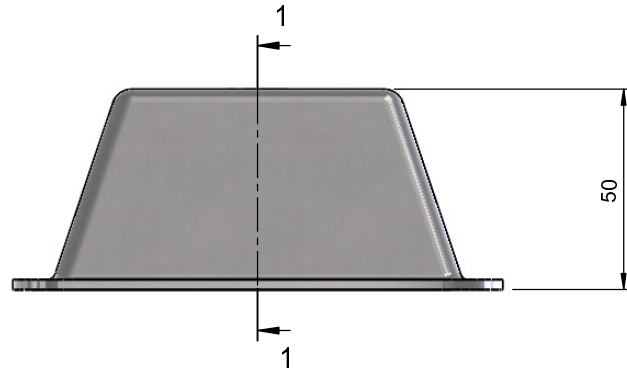

SECTION 1-1

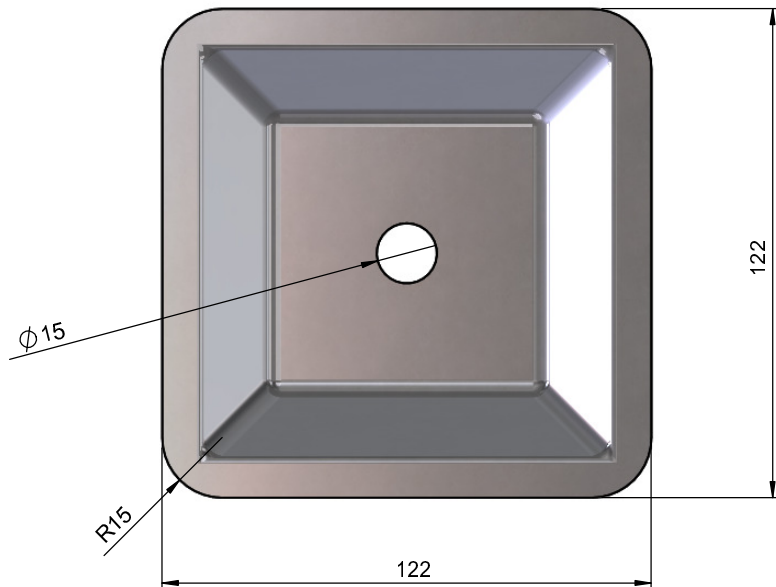

0	17/2/12	ISSUED FOR MANUFACTURE	GC		
REV	DATE	DESCRIPTION	DRN	CHKD	APPR

TITLE: **STILLAGE FOOT**

UNLESS STATED OTHERWISE		
GENERAL TOLERANCES:		
FABRICATION	UP TO 1000mm	+/- 2mm
	1001mm & ABOVE	+/- 3mm
ANGULAR	+/- 0.5 DEGREE	
WEIGHT	+/- 10% (DUE TO MATERIAL PROPERTIES & TOLERANCES)	

NAME	SIGNATURE	DATE
G. CRICK		17/2/12
CHK'D		
FINISH:		
NONE		

MATERIAL:
CARBON STEEL



Dwg/Stock No. **ZND524-9** Revision **0**

THE COMPANY RETAIN THE RIGHT TO PERIODICALLY ALTER INFORMATION WITHIN THIS DRAWING SHEET AND WILL ATTEMPT TO NOTIFY ALL PARTIES CONCERNED OF ANY CHANGES AND THE INFORMATION ON THIS SHEET SHOULD NOT BE REPRODUCED WITHOUT THEIR WRITTEN CONSENT.